

SX-4400

Magnetorque non-contacting steering torque sensor

Magnetorque is ideally suited for demanding Electric Power Steering systems.

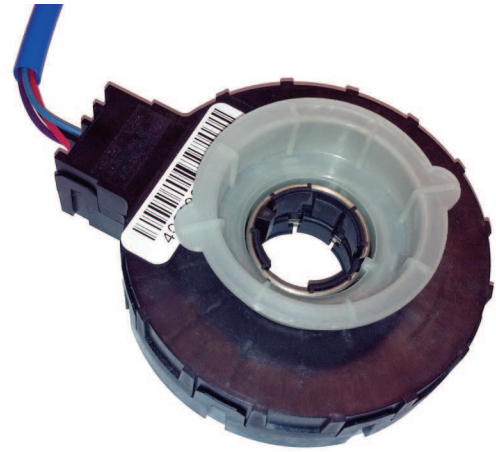

ELECTRICAL¹

Supply Voltage	4.5 to 5.5 VDC
Linearity	±3%
Hysteresis	±1.3%
Microgradient	±30% of theoretical slope over 0.4° interval
Sensed Angle	±5°
Supply Current	8 to 16 mA
Clamp Low	8 to 12%
Clamp High	88 to 92%
Sensitivity	0.388 to 0.412 V/°

MECHANICAL

Mechanical Travel, Input Rotor	Continuous
Mechanical Travel, Output Rotor	Continuous
Turning Torque (rotor to rotor)	0 NM (non-contacting)
Turning Torque (input rotor to housing)	0 NM (non-contacting)
Turning Torque (output rotor to housing)	0.05 NM maximum
Weight	105 grams maximum

ENVIRONMENTAL

Operating Temperature Range	-40°C to +85°C
Vibration	10 to 55 Hz with 1 mm P-P constant displacement, 120 hours each of 3 planes
Input Rotor Rotational Life	Infinite (floating)
Output Rotor Rotational Life	10 million cycles
Storage Temperature Range	-55°C to +125°C

¹ Design can be programmed to meet other angles and amplitudes. Specifications per 122-4400-44A and subject to change without notice.

SX-4400

OUTPUT CHART

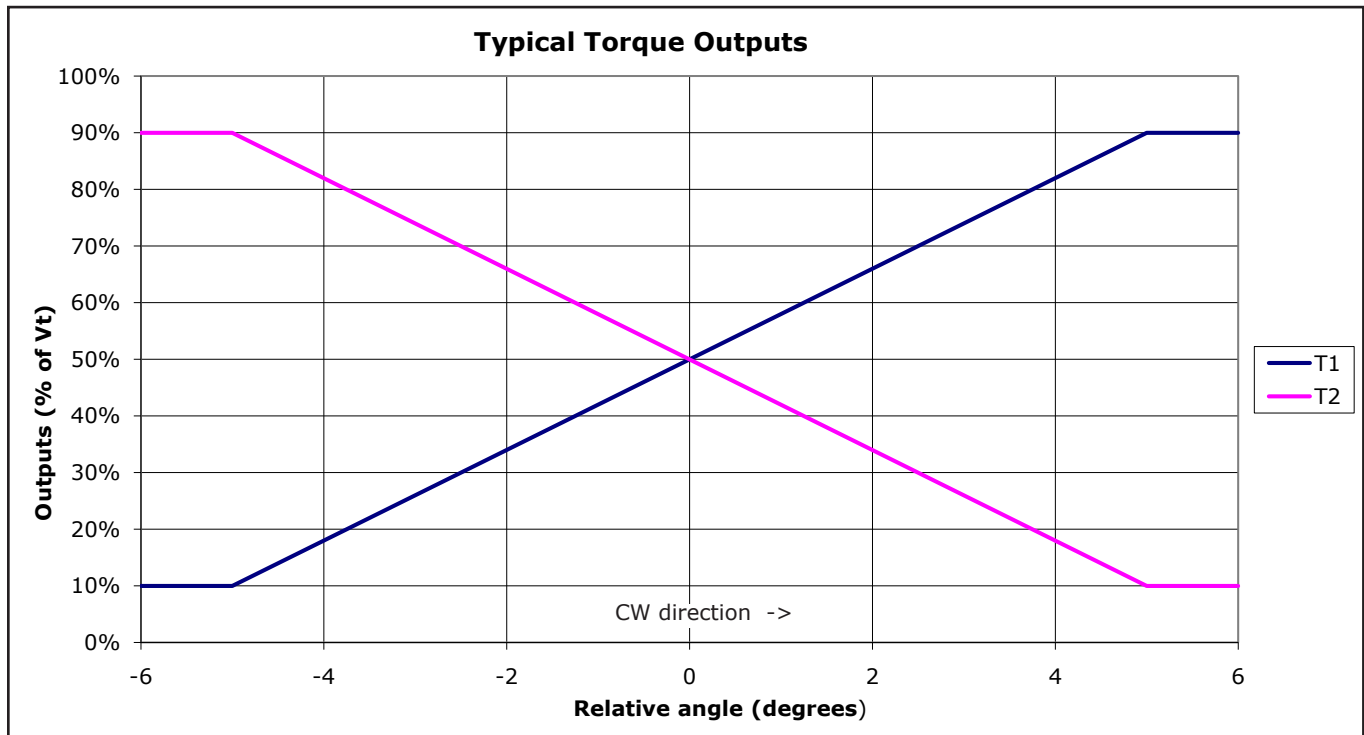

PINOUTS & RECOMMENDED INTERFACE

PIN No.	SIGNAL	WIRE COLOR
1	VCC	RED
2	GND	BLACK
3	N/A	N/A
4	T1	BLUE
5	T2	PURPLE
6	N/A	N/A

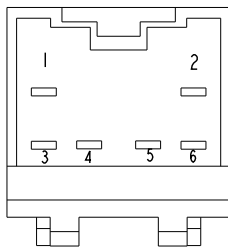

YASAKI MATING CONNECTOR #7123-8365
CONNECTOR FRONT VIEW

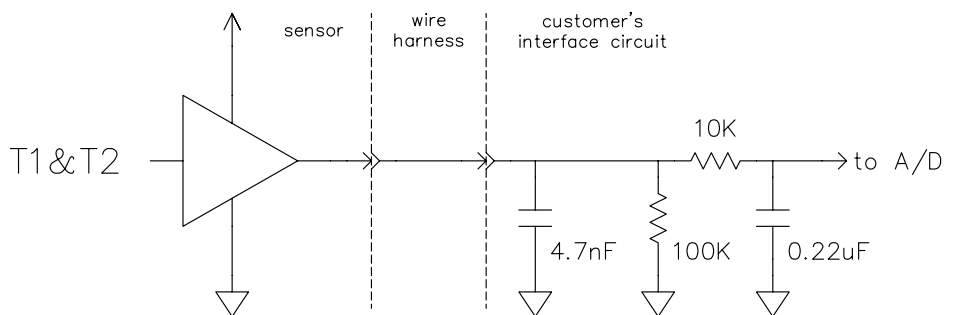

BI Technologies Corporation

4200 Bonita Place, Fullerton, CA 92835 USA

Phone: 714 447 2345 Website: www.bitechnologies.com

May 9, 2012

SX-4400

OUTLINE DRAWING

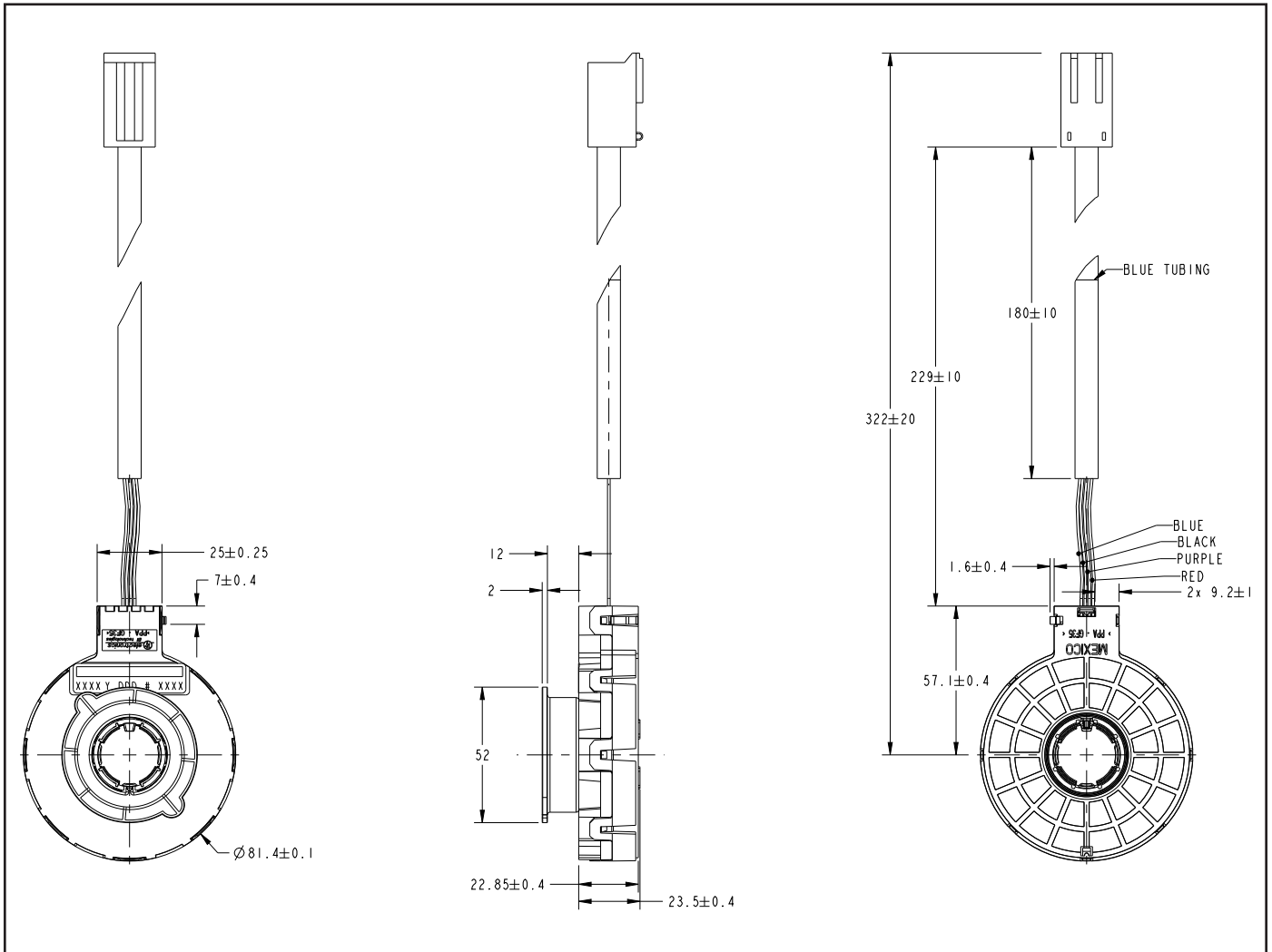

Tolerances ± 1 mm unless otherwise specified. See drawing # 122-4400-50 for details