

MODEL A

1-13/16" Diameter

10-Turn

Wirewound

Precision Potentiometer



2

ELECTRICAL

Resistance Range, Ohms	10 to 500K
Standard Resistance Tolerance	< 100 Ohms = $\pm 5\%$, ≥ 100 Ohms = $\pm 3\%$
Minimum Practical Resistance Tolerance	$\pm 1\%$
Independent Linearity	< 300 Ohms = $\pm 0.50\%$, ≥ 300 Ohms = $\pm 0.25\%$
Minimum Practical Independent Linearity	$\pm 0.15\%$, ≤ 20 Ohms $\pm 0.10\%$, < 100 Ohms $\pm 0.075\%$, < 300 Ohms $\pm 0.05\%$, ≥ 300 Ohms
Power Rating, Watts	5.0 at 40°C derating to 0 at 85°C
Input Voltage, Maximum	1,000Vdc not to exceed power rating
Dielectric Strength	1,000V rms
Insulation Resistance, Minimum	1,000 Megohms
Noise, Maximum	500 Ohms: RT ≤ 2613.7 Ohms 250 Ohms: RT > 2613.7 Ohms
Actual Electrical Travel	3600° + 4° - 0°
Tap Tolerance	≤ 20 Ohms = $\pm 3^\circ$, < 100 Ohms = $\pm 2^\circ$ < 300 Ohms = $\pm 1.5^\circ$, ≥ 300 Ohms = $\pm 1^\circ$
End Voltage, Maximum (% of input voltage)	10 Ohms = 3%, 25 Ohms = 1.2% 50 Ohms = 0.6%, ≥ 100 Ohms = 0.25%

This model available in a hybrid version – contact factory for details.

ENVIRONMENTAL (MIL-R-12934)

Operating Temperature Range	Static: -65°C to +85°C Dynamic: -40°C to +85°C
Temperature Cycling	5 cycles, -65°C to +85°C (5% ΔR)
Shock, 6ms Sawtooth	100G's (0.1ms discontinuity max.)
Vibration	6 hours, 10 to 55 Hz (5% ΔR , 0.1ms discontinuity max.)
Moisture Resistance	Ten 24 hour cycles (3% ΔR)
High Temperature Exposure	1,000 hours at 85°C (5% ΔR)
Rotational Load Life	2 mil. shaft rev. + 900 hrs. at rated wattage at 40°C (5% ΔR)

Specifications subject to change without notice.

MECHANICAL

Total Mechanical Travel	3600° + 4° - 0°
Number of Gangs, Maximum	3
Weight, Nominal (Single Gang)	4.4 oz.
Static Stop Strength	550 oz.-in.
Backlash, Maximum	1°
Panel Nut Tightening Torque, Maximum	25 lb.-in.
Shaft End Play, Maximum	.005"
Shaft Runout, T.I.R., Maximum	.0005"
Pilot Diameter Runout, T.I.R., Maximum	.002"
Lateral Runout, T.I.R., Maximum	.003"
Shaft Radial Play, Maximum	.003"
Start/Run Torque, Maximum (per gang)	3.0 oz.-in.

STANDARD RESISTANCE VALUES, OHMS

Total Resistance	Theoretical Resolution (% Nominal)	Tempco of Wire
10	0.082	+800 ppm/°C *
25	0.040	+800 ppm/°C *
50	0.031	+800 ppm/°C *
100	0.040	±20 ppm/°C
200	0.031	±20 ppm/°C
500	0.024	±20 ppm/°C
1K	0.021	±20 ppm/°C
2K	0.016	±20 ppm/°C
5K	0.014	+130 ppm/°C *
10K	0.011	+130 ppm/°C *
20K	0.009	+130 ppm/°C *
50K	0.007	+130 ppm/°C *
100K	0.006	±20 ppm/°C
200K	0.005	±20 ppm/°C
300K	0.005	±20 ppm/°C
500K	0.005	±20 ppm/°C

* Lower tempco available as a special model.

OUTLINE DIMENSIONS (Inch/mm)

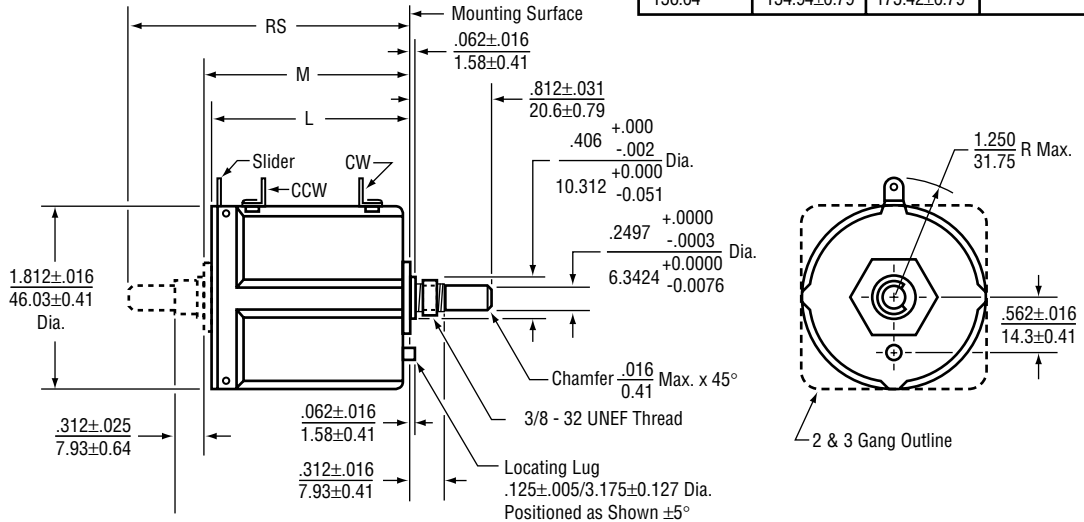

Dim. "L"	Dim. "M"	Dim. "RS"	No. of Gangs
$\frac{2.016}{51.21}$ Max.	$\frac{2.062 \pm .031}{52.38 \pm 0.79}$	$\frac{2.875 \pm .031}{73.03 \pm 0.79}$	1
$\frac{4.243}{107.78}$ Max.	$\frac{4.205 \pm .031}{106.81 \pm 0.79}$	$\frac{5.016 \pm .031}{127.41 \pm 0.79}$	2
$\frac{6.143}{156.04}$ Max.	$\frac{6.100 \pm .031}{154.94 \pm 0.79}$	$\frac{6.906 \pm .031}{175.42 \pm 0.79}$	3

2

METRIC CONVERSIONS

1 in.	25.4mm	1 oz.-in.	0,007 N-m
1 oz.	28.4 gm	1 lb.-in.	0,113 N-m

SPECIAL FEATURE CODES

Center Tap	CT
Linearity Tape	LT
Rear Shaft Extension	RS
Flatted Shaft	FS
Slotted Shaft	SS
Shaft Lock	SL
Color Coded	CC
Additional Gangs	2G or 3G

ORDERING INFORMATION

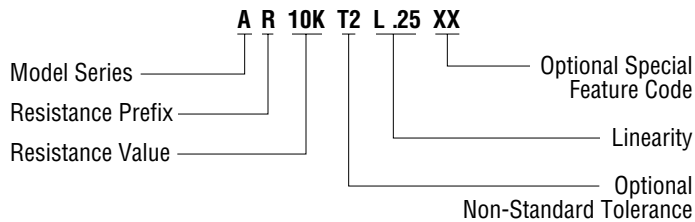

MATCHING TURNS COUNTING DIALS

2606, 2607, 2626, 2627, 2646, 2647, 2126, 2606S, 2607S, 2646S, 2647S, RB

CIRCUIT DIAGRAM

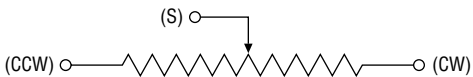

NOTES

Metric equivalents, based on 1 inch = 25.4mm are rounded to the same number of significant figures as in the original English units and are provided for general information only.

Tolerances unless otherwise specified:
 Linear = $\pm .01$ inches
 (.25mm)
 Angular = ± 2 degrees

