

Thick Film 2512 Surge Resistors

BSR Series

- **1.2/50 microsecond 250V pulse**
- **10/700 microsecond 250V pulse**
- **Nickel barrier terminations**
- **Double glass passivation**

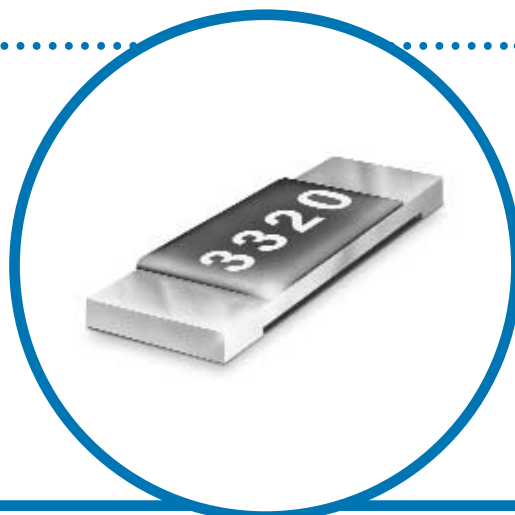

Applications

Telephone lines are often subject to a variety of voltage disturbances which fall into two main categories - short duration, high voltage transients caused by lightning strikes and longer duration, over voltages which may be caused by direct connection to mains power lines. The advent of electronic switching has meant that sophisticated methods of protection against these two fault conditions has to be incorporated to ensure that potential damage is limited.

The two types of protection are: primary, which attempts to deal with the bulk of the energy from a fast transient, particularly lightning strikes and power crosses and secondary, which provides a further level of protection to prevent damage to sensitive electronic circuits.

The possibility of disturbances in the line is dependent on the environment of the equipment installation. In the case of a PABX, where the telephone line, terminal equipment and the line interface are all installed in the same building, the possibility of induced lightning transients is greatly reduced and the opportunity for damage induced by direct connection to mains is low. For these reasons the degree of protection is much less than for equipment connected outside the building where the risk increases dramatically.

BI Technologies is involved in secondary protection for all types of environment. The BSR Series has been specifically designed for PABX where cost is of paramount importance. For central switches, the tip and ring resistors are expected to perform identically to maintain the correct resistance for a balanced line system. Both resistors are therefore generally produced on a common substrate, which may be through hole or surface mount, and perform close to one another under all foreseeable fault conditions in both common and differential modes. For PABX, tracking is not required because an individual resistor is used which normally runs at low power yet has the ability to withstand considerable power for long periods and has good characteristics under high voltage transient conditions.

The BSR Series is a surface mount chip resistor in a standard 2512 package which utilizes special resistor film to handle the high voltage with sophisticated laser trimming to prevent flash over. In the event of a very high voltage pulse the resistor will go open-circuit preventing damage to surrounding components or the printed circuit board. Two units are required for each incoming line to protect both tip and ring individually and collectively. The resistor is made from nonflammable material.

Electrical

Surge Capability, Max.	S1.2 / 50 μ s, 250 V; 10 / 700 μ s, 250 V ($\Delta R \pm 5\% + 0.1\Omega$)
Standard Resistance Range, Ohms	0.05 to 10K Ohms
Standard Resistance Tolerances	$\pm 5\%$, $\pm 10\%$, $\pm 20\%$ Optional : $\pm 1\%$, $\pm 2\%$
Operating Temperature Range	-55°C to +125°C
Temperature Coefficient of Resistance, Max.	± 100 ppm/°C above 10 Ohms
Power Ratings, Watts, at 70°C (See Note)	1 and 2
Operating Voltage, Max.	100 V dc or \sqrt{PR} whichever is less

Note: For 2 watts limit part temperature to +155°C

General Note

TT electronics reserves the right to make changes in product specification without notice or liability. All information is subject to TT electronics' own data and is considered accurate at time of going to print.

Environmental

Short Time Overload, Max.	2.5 x rated voltage ($\Delta R \pm 1\% + 0.1 \Omega$)
Temperature Cycling	-55°C to +125°C, 5 cycles ($\Delta R \pm 5\% + 0.1 \Omega$)
Moisture Resistance	1,000 hours at 40°C, 95% RH ($\Delta R \pm 3\% + 0.1 \Omega$)
Load Life	1,000 hours at 70°C + Rated Voltage, Max. ($\Delta R \pm 3\% + 0.1 \Omega$)
Resistance to Solder Heat	260°C for 10 sec. ($\Delta R \pm 5\% + 0.1 \Omega$)

Construction

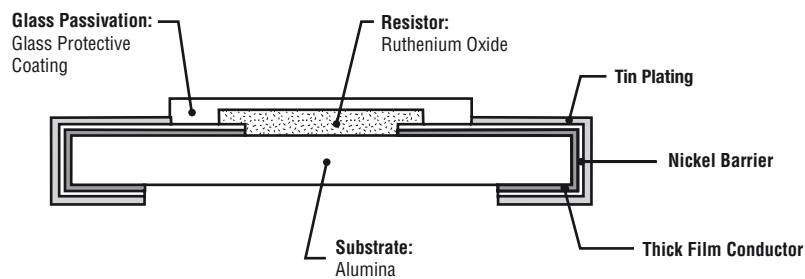

General Note

TT electronics reserves the right to make changes in product specification without notice or liability. All information is subject to TT electronics' own data and is considered accurate at time of going to print.

Surge Waveform Definition

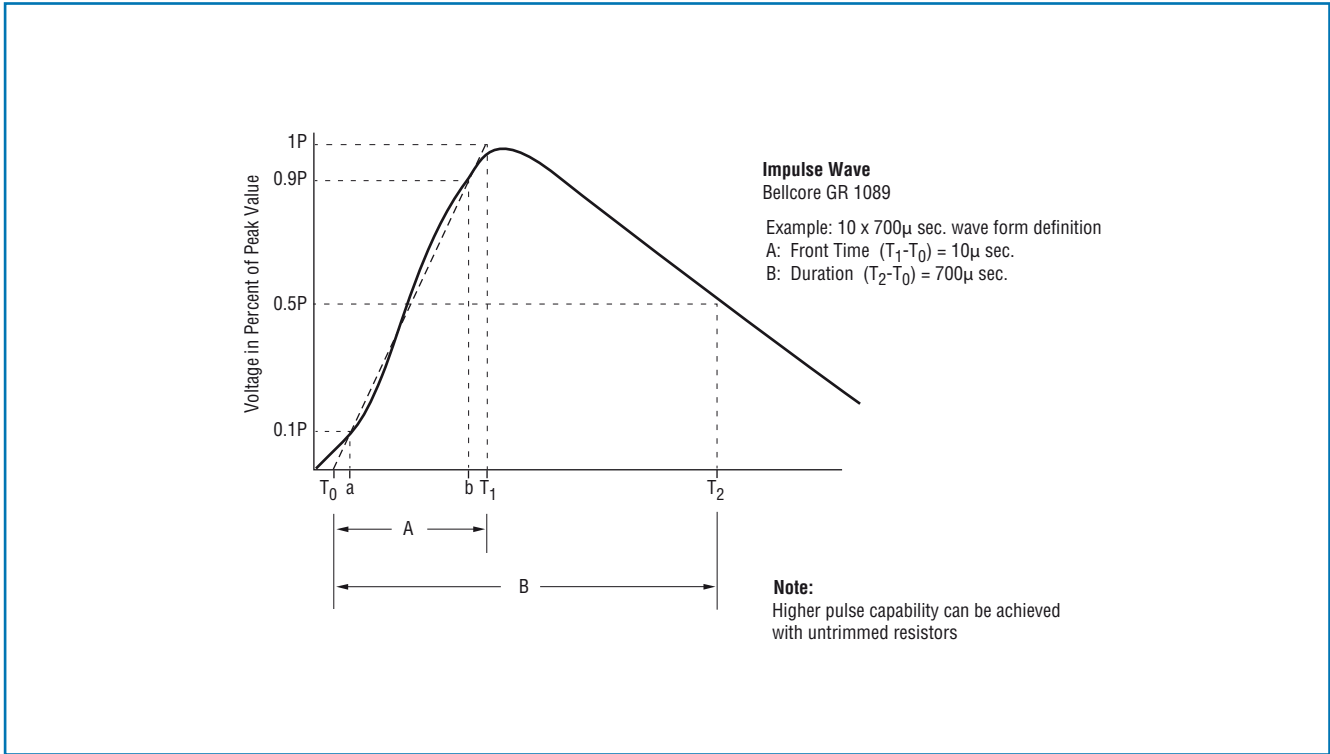

Outline Dimensions (Inch/mm)

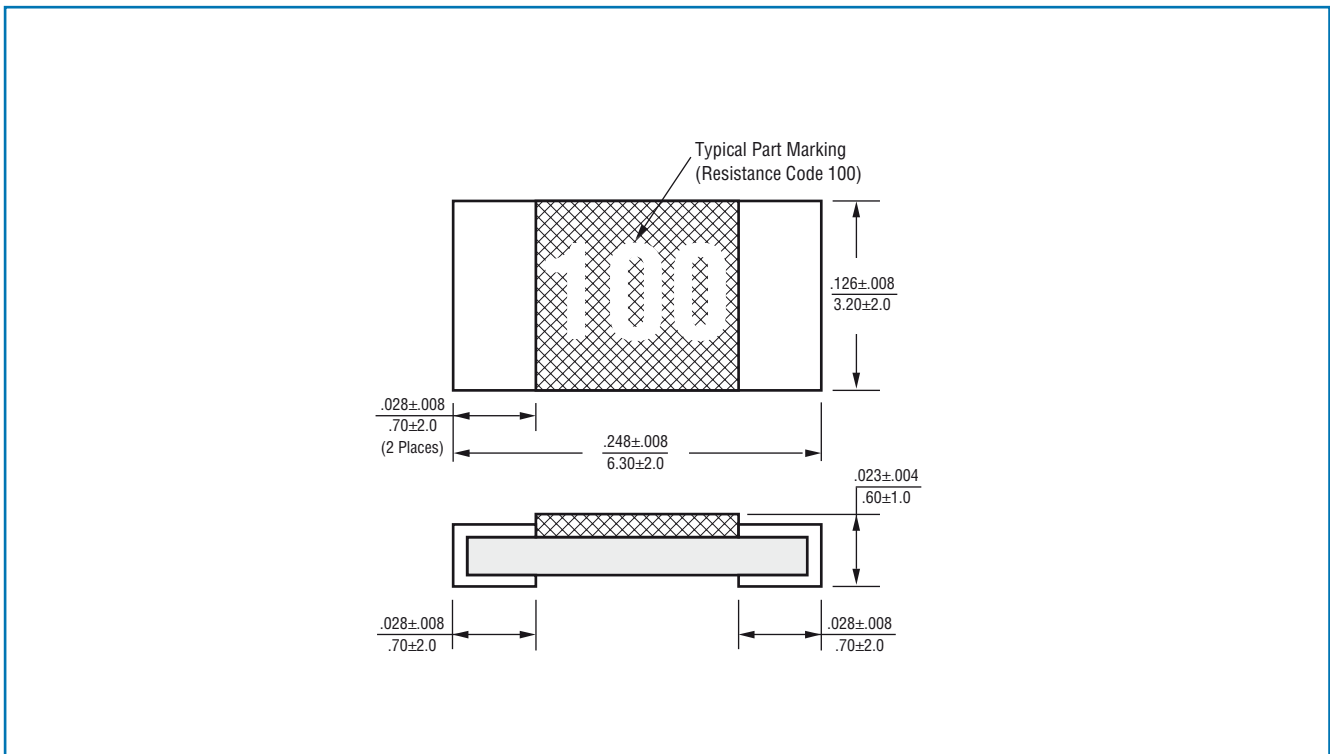

General Note

TT electronics reserves the right to make changes in product specification without notice or liability. All information is subject to TT electronics' own data and is considered accurate at time of going to print.

Packaging (Inch/mm)

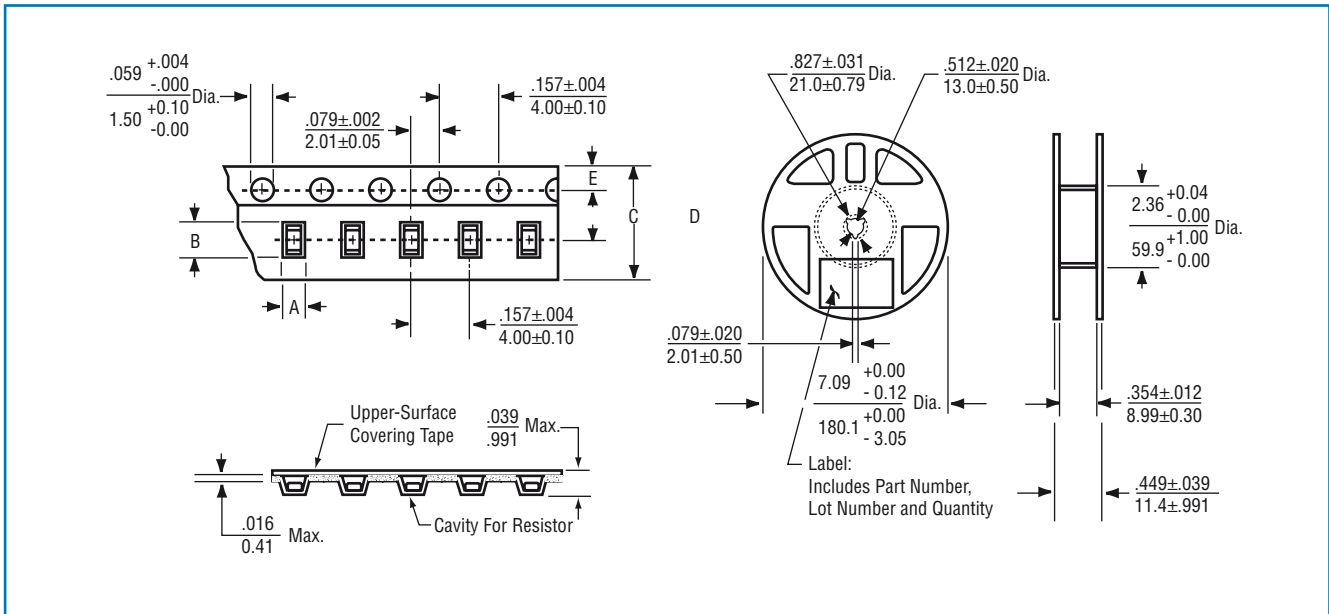

7" Reel Diameter - 4K Per Reel

Dim. A	Dim. B	Dim. C	Dim. D	Dim. E
$\frac{.138 \pm .004}{3.51 \pm 0.10}$	$\frac{.266 \pm .004}{6.76 \pm 0.10}$	$\frac{.472 \pm .008}{11.99 \pm 0.20}$	$\frac{.217 \pm .002}{5.51 \pm 0.05}$	$\frac{.069 \pm .004}{1.75 \pm 0.10}$

Ordering Information

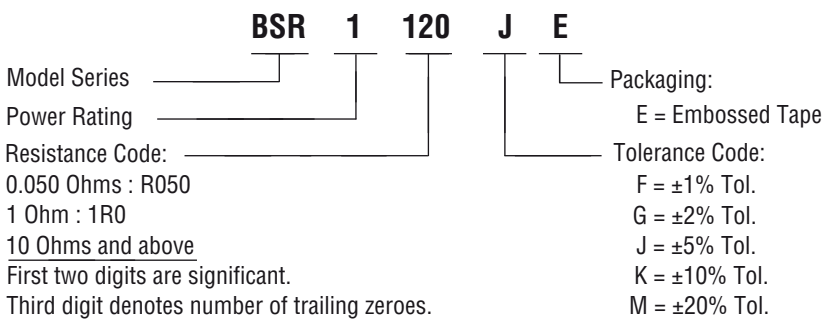

General Note

TT electronics reserves the right to make changes in product specification without notice or liability. All information is subject to TT electronics' own data and is considered accurate at time of going to print.