

MODELS 627, 628

Model 627, 628 Series

- **.220" Small Outline**
- **Dual-In-Line**
- **Thick Film**
- **Surface Mount**
- **Resistor Networks**
- **RoHS Compliant**

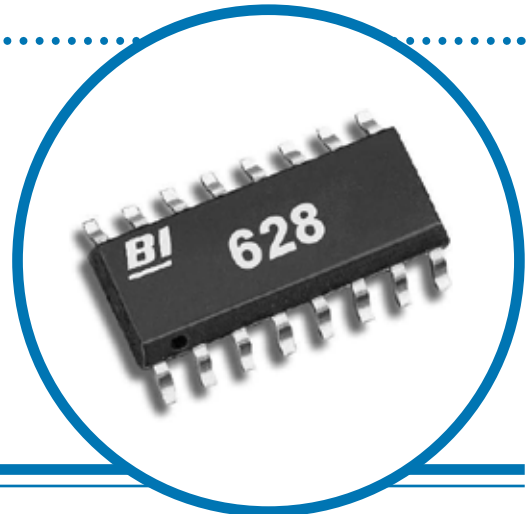

Electrical

Standard Resistance Range, Ohms	10 to 1Meg (Plus "0" Ohm Jumper)
Standard Resistance Tolerance, at 25°C	±2% (<33Ω = ±1 Ohm) (Optional: F Tol. = ±1%)
Operating Temperature Range	-55°C to +125°C
Temperature Coefficient of Resistance	±100ppm/°C (<100Ω = ±250ppm/°C)
Temperature Coefficient of Resistance, Tracking	±50ppm/°C
Maximum Operating Voltage	50Vdc or √PR
Insulation Resistance	≥10,000 Megohms

Environmental

Thermal Shock plus Power Conditioning	ΔR 0.70%
Short Time Overload	ΔR 0.25%
Moisture Resistance	ΔR 0.50%
Mechanical Shock	ΔR 0.25%
Vibration	ΔR 0.25%
Low Temperature Operation	ΔR 0.25%
High Temperature Exposure	ΔR 0.50%
Load Life, 2000 Hours (≤330Ω = ±0.5 Ohm)	ΔR 0.50%
Resistance to Solder Heat (Total Immersion in solder at 280°C for 10 sec.)	ΔR 0.25%
Dielectric Withstanding Voltage	200V for 1 minute
Temperature Exposure, Maximum	215°C for 3 minutes
Marking Permanency	MIL-STD-202, Method 215
Lead Solderability	MIL-STD-202, Method 208
Flammability	UL-94V-0 Rated
Storage Temperature Range	-55°C to +150°C

General Note

TT electronics reserves the right to make changes in product specification without notice or liability. All information is subject to TT electronics' own data and is considered accurate at time of going to print.

Mechanical

Lead Material	96-96.5%Sn, 3.5-4%Ag
Lead Configuration	Gull Wing
Lead Coplanarity	±0.002 in. (0.051mm)
Substrate Material	Alumina
Resistor Material	Cermet
Body Material	Epoxy

Standard Resistance Values, Ohms

A Circuit (Isolated Resistors)						B Circuit (Bussed Resistors)					
Bold type represents stock standard values for 'A' Circuit						Bold type represents stock standard values for 'B' Circuit					
Ohms	Code	Ohms	Code	Ohms	Code	Ohms	Code	Ohms	Code	Ohms	Code
22	220	1.2K	122	39K	393	22	220	1.2K	122	39K	393
33	330	1.5K	152	47K	473	33	330	1.5K	152	47K	473
39	390	1.8K	182	56K	563	39	390	1.8K	182	56K	563
47	470	2K	202	68K	683	47	470	2K	202	68K	683
56	560	2.2K	222	82K	823	56	560	2.2K	222	82K	823
68	680	2.7K	272	100K	104	68	680	2.7K	272	100K	104
82	820	3.3K	332	120K	124	82	820	3.3K	332	120K	124
100	101	3.9K	392	150K	154	100	101	3.9K	392	150K	154
120	121	4.7K	472	180K	184	120	121	4.7K	472	180K	184
150	151	5.6K	562	220K	224	150	151	5.6K	562	220K	224
180	181	6.8K	682	270K	274	180	181	6.8K	682	270K	274
220	221	8.2K	822	330K	334	220	221	8.2K	822	330K	334
270	271	10K	103	390K	394	270	271	10K	103	390K	394
330	331	12K	123	470K	474	330	331	12K	123	470K	474
390	391	15K	153	560K	564	390	391	15K	153	560K	564
470	471	18K	183	680K	684	470	471	18K	183	680K	684
560	561	20K	203	820K	824	560	561	20K	203	820K	824
680	681	22K	223	1 Meg	105	680	681	22K	223	1 Meg	105
820	821	27K	273			820	821	27K	273		
1K	102	33K	333			1K	102	33K	333		

J Circuit (Dual Terminators)					
Ohms (R1/R2)	Code (R1/R2)	Marking	Ohms (R1/R2)	Code (R1/R2)	Marking
120/120	121/121	45	330/470	331/471	10
150/150	151/151	40	390/390	391/391	42
180/300	181/301	31	470/470	471/471	43
220/220	221/221	39	1K/3.3K	102/332	35
220/330	221/331	08	3K/6.2K	302/662	13
270/270	221/331	41	6.8K/22K	682/223	29
330/390	331/391	09	-	-	-

General Note

TT electronics reserves the right to make changes in product specification without notice or liability. All information is subject to TT electronics' own data and is considered accurate at time of going to print.



www.bitechnologies.com www.irctt.com www.welwyn-tt.com

Outline Dimensions (Inch/mm)

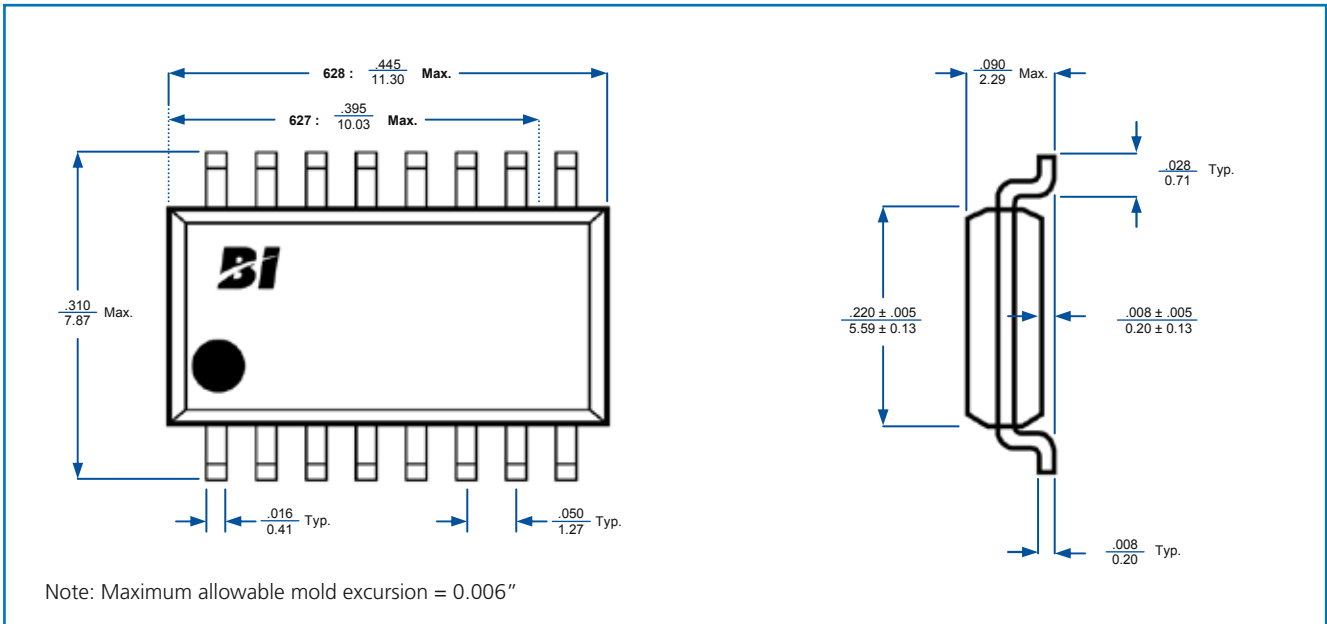

Schematics

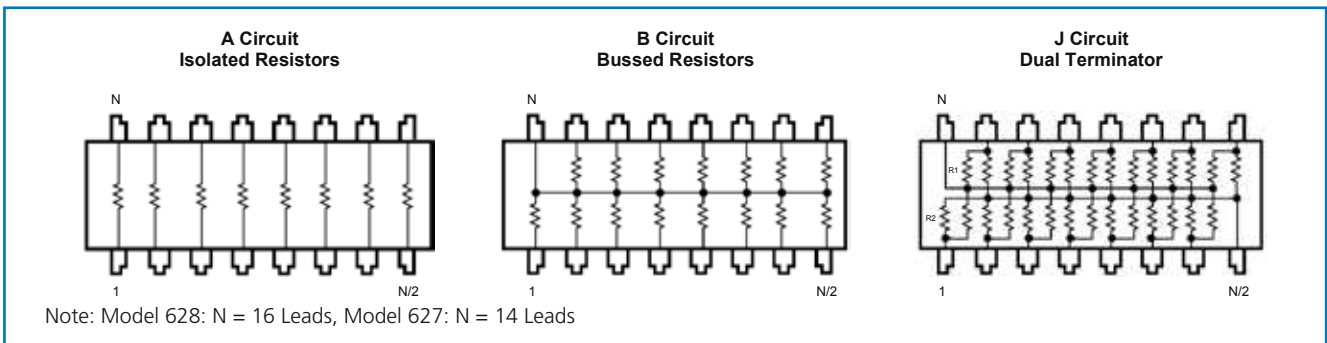

Solder Pad Layout (Inch/mm)

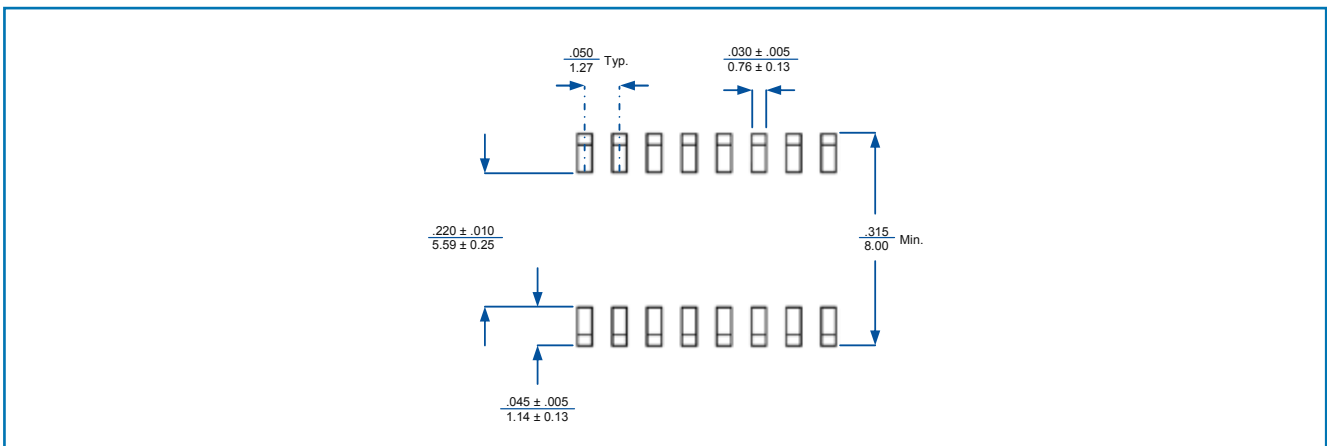

General Note

TT electronics reserves the right to make changes in product specification without notice or liability. All information is subject to TT electronics' own data and is considered accurate at time of going to print.



www.bitechnologies.com www.irctt.com www.welwyn-tt.com

Typical Part Marking

Part Number:	Part Marking:
628A330	8A330
628A331	8A331
628J221/331	8J08

Power Dissipation, Watts At 70°C

— Resistor (Per Circuit) —				
Model	Package	A	B	J
627	1.28	0.32	0.16	0.16
628	1.28	0.32	0.16	0.16

Packaging

Standard:	Tape & Reel Conforms to requirements of EIA-481. All units orientated with lead #1 to the left of direction of feed.	
Tape	Width =	24mm
	Pocket =	Embossed Plastic, Antistatic
	Pitch =	12mm
Reel:	Diameter =	13" (300mm) Maximum
	Capacity =	2,000 Units
Option:	Magazines Conforms to EIA and JEDEC standards. All units orientated with lead #1 to the same side.	
Magazine:	Magazine: Capacity =	50 Units

General Note

TT electronics reserves the right to make changes in product specification without notice or liability.
All information is subject to TT electronics' own data and is considered accurate at time of going to print.

Applicable Documents

MIL-R-914 - Resistor Networks, Fixed, Film, Surface Mount Established Reliability General Specifications
MIL-STD-105 - Sampling Procedures and Tables for Inspection by Attributes
MIL-STD-202 - Test Methods for Electronics and Electrical Component Parts
EIA-481 - Carrier Taping of Surface Mount Components for Automatic Handling
EIA-PDP-100 - SOGN-0002 Outline Dimensions

Ordering Information

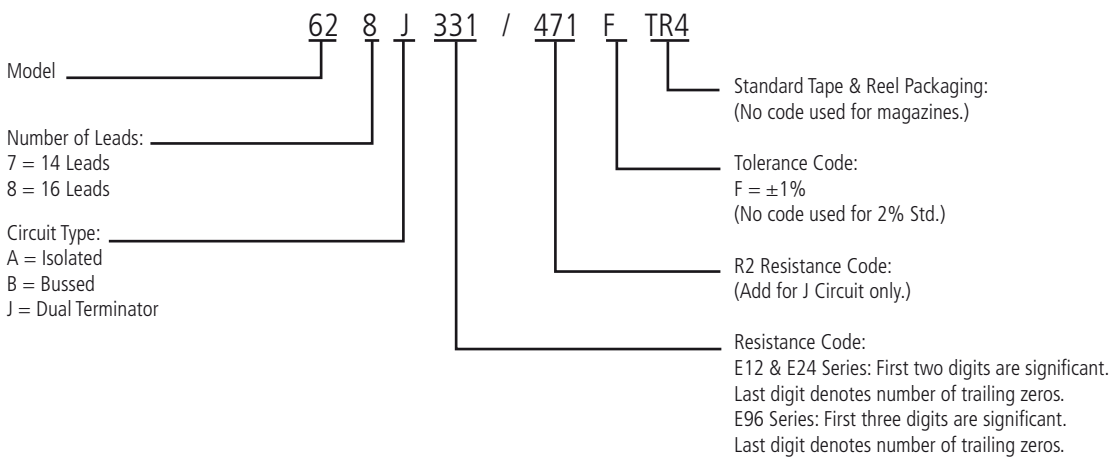

General Note

TT electronics reserves the right to make changes in product specification without notice or liability. All information is subject to TT electronics' own data and is considered accurate at time of going to print.



www.bitechnologies.com www.irctt.com www.welwyn-tt.com