

**Model EN16**  
**16mm Rotary Encoder**  
**2 Bits Gray Code**  
**Incremental/Contacting Type**  
**Metal Bushing/Plastic Shaft**  
**RoHS Compliant**

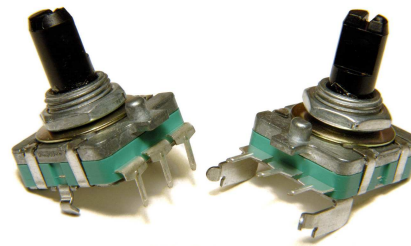

**MODEL STYLES**

Top Adjust, PCB pins	EN16-H
Side Adjust, PCB pins	EN16-V

**ELECTRICAL<sup>1</sup>**

Pulses ( Per Revolution )	12 & 24
Closed Circuit Resistance, Ohms	3 Ohms, max.
Contact Rating	0.5mA/ 5Vdc
Operating Current, Maximum	0.5mA
Dielectric Strength	50Vac/ 1mA, 1 minute
Insulation Resistance, Minimum	10M ohms at 50Vdc/ 1mA
Sliding Noise ( at 60 RPM )	2.0ms max.
Contact Bounce ( at 15 RPM)	5.0ms max.
Operating speed ( RPM )	100 RPM max.
Actual Electrical Travel, Nominal	Continuous

**MECHANICAL**

Total Mechanical Travel	Continuous
Detents (per Revolution)	0,12, 24
Rotational Torque of Detent, Maximum	2.5 oz-in

**ENVIRONMENTAL**

Operating Temperature Range	-30°C to +85°C
Rotational Life	30,000 cycles

<sup>1</sup> Specifications subject to change without notice.

# Model EN16

## ORDERING INFORMATION<sup>2</sup>

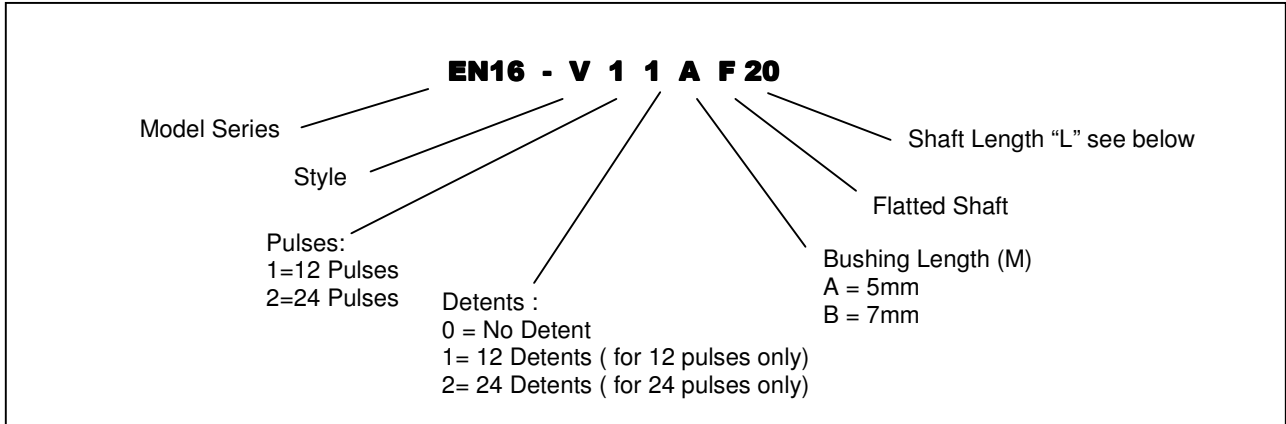

### Shaft Length options

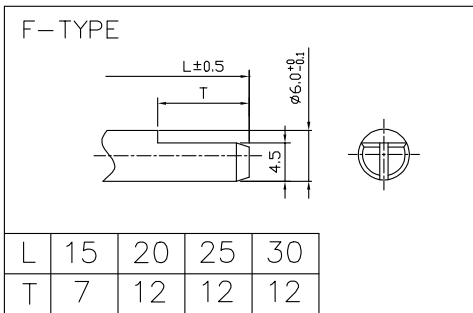

## CIRCUIT DIAGRAM

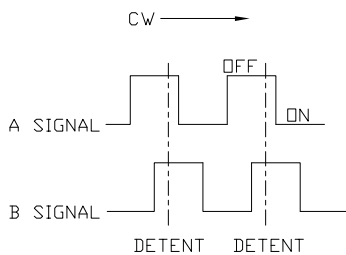

<sup>2</sup> Contact our customer service for custom designs and features.

# Model EN16

## OUTLINE DRAWING

### EN16-H (Top Adjust, PCB pins)

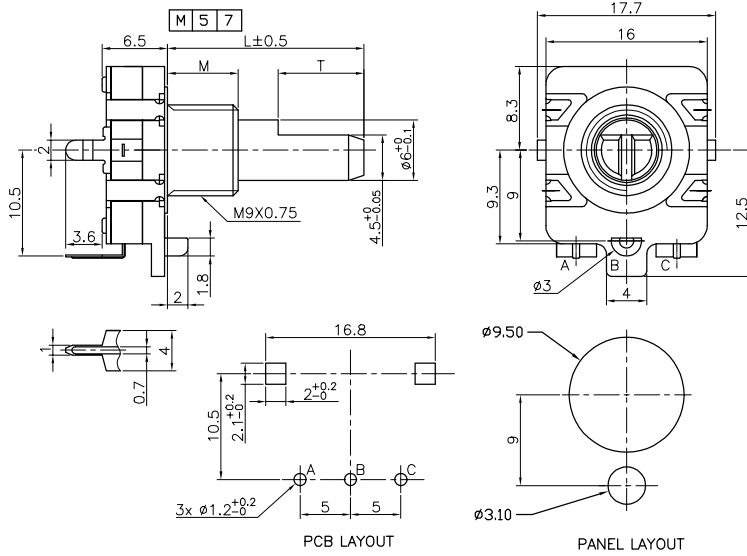

### EN16-V (Side Adjust, PCB pins)

