

# Agilent 11757B Multipath Fading Simulator/Signature Test Set

## Product Overview

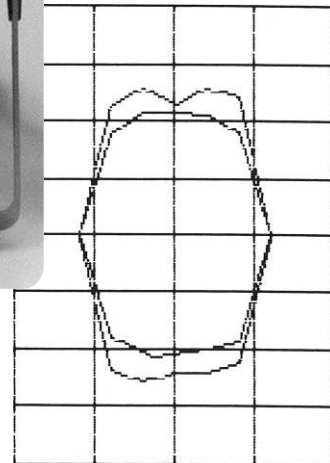

Economical simulator automatically measures digital microwave radio signatures to verify adaptive equalizer performance

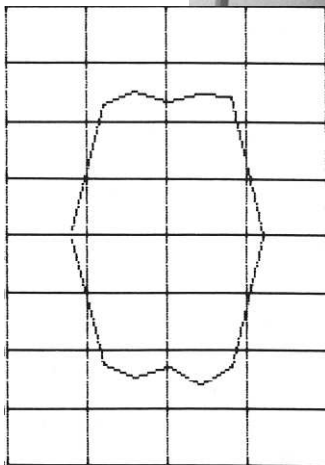
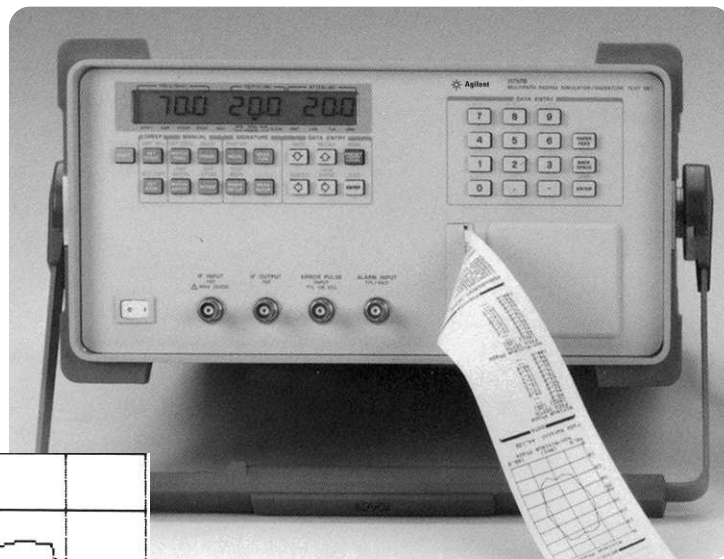

# The Agilent 11757B makes multipath fade testing easy

- *Characterize adaptive equalizers in the design lab*
- *Speed signature measurements in production*
- *Verify equalizer performance at commissioning*
- *Identify faulty equalizers during troubleshooting*

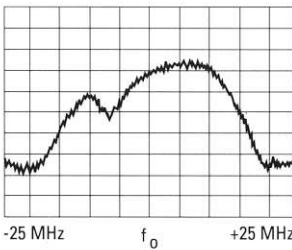

Multipath fading is a major cause of outage on a digital radio link. This radio spectrum shows severe in-band fading.

The Agilent 11757B brings accurate, economical multipath fade testing to digital microwave radio. Now with built-in signature measurements, tests once confined to the laboratory can be made and recorded quickly in manufacturing and even at the radio site.

Testing susceptibility to multipath conditions is especially important since fading is recognized as one of the predominant causes of unacceptable bit error rate and link outages. As digital microwave radios move to increasingly complex modulations, such as 64 and 256 QAM, the need for multipath fade testing becomes even more crucial to working microwave communication systems.

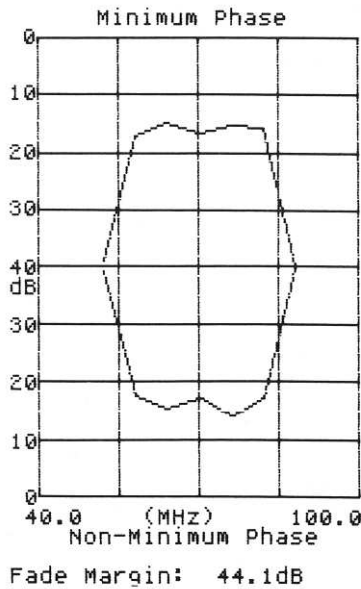

Traditional, manual signature techniques and even computer-automated methods can take as long as 30 minutes. With the 11757B, the M-Curve signature measurement is fast and simple. A hardcopy result is in your hands in less than one minute.

## Multipath fade simulation

Waiting for a natural multipath fade is impractical in the field and impossible in the lab. Yet a radio's adaptive equalizers are not exercised unless the received signal has experienced some propagation distortion. The 11757B simulates a simplified 3-ray model of both static and dynamic multipath fades by introducing a precisely controlled notch in or around the transmission bandwidth. This allows precise measurements of the equalizers' ability to compensate for such distortions.

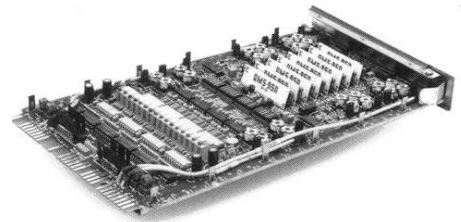

The equalizers' ability to cope with multipath fades can be measured with a multipath fading simulator.

### M-Curve signatures

The 11757B has built-in M-Curve signature capability. An important bottom line test of a radio's multipath fading protective systems, these signatures show the range of acceptable radio performance with and without multipath protection. By stressing the radio's equalizers with controlled amounts of multipath fade and monitoring the radio's bit error rate, the 11757B automatically measures and records a radio's signature on a built-in printer. These signatures are useful for comparing different radios or characterizing individual radio performance.

Dispersive Fade Margin and Recovery Time

Static M-Curve Signatures

Dynamic M-Curve

Dynamic S-Curve

Hysteresis Measurements



# Thoroughly characterize adaptive equalizer performance before the radio leaves the factory

As competition in the digital microwave radio industry continues to increase, it is more critical than ever to provide performance tests that set you apart from the rest. More microwave radio operators are requiring M-Curve signature specifications to see just that.

## Flexible measurements

Ideal for a design lab or a manufacturing floor, the 11757B makes a variety of signature measurements. The signature test set has both static and dynamic measurements built-in. Other measurement requirements can easily be accommodated because all parameters can be controlled with HP-IB if further computer analysis is required.

## Diversity systems

One way of protecting radio links from multipath fading is through space and/or frequency diversity. Testing diversity receivers requires two paths of controlled fading activity. An economical solution for testing diversity systems is to use two synchronized 11757B multipath fading simulators. One simulator is placed in each IF of the receiver prior to its combiner. Using synchronized fade simulation, combiner performance can be measured under a wide range of known conditions.

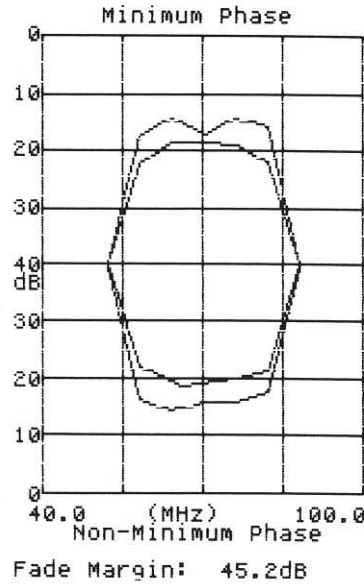

The performance of the radio's equalizers can be dependent on whether the notch is moving from a shallow to deep fade condition, or from a deep to a shallow fade. The 11757B automatically makes hysteresis measurements and prints out both results on the same plot.

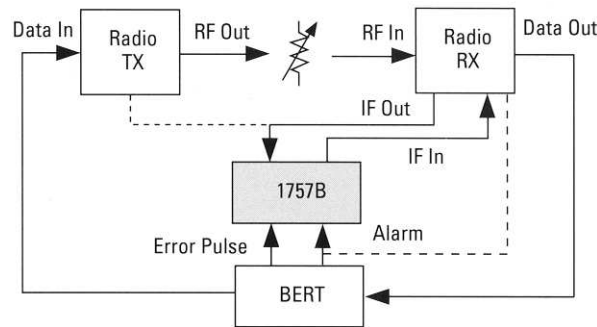

Measure signatures by placing the 11757B in the IF path of the receiver. The radio is connected either RF back-to-back or in an IF loopback configuration.

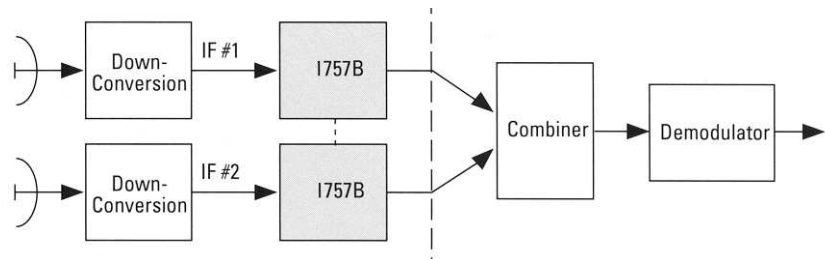

To test diversity systems, two 11757B multipath fading simulators can be synchronized. One is inserted in each IF of the radio under test prior to the combiner.

## Dynamic tests

Traditionally multipath fading has been a static measurement, but real-life multipath fading changes over time. The radio must adapt to dynamically changing fade conditions. One gauge of a radio's dynamic performance is its ability to maintain an acceptable BER while a multipath notch is sweeping through its IF signal. A moving notch is far beyond the capability of many home-built fading simulators. However, it is an easy matter to create a swept notch with the 11757B multipath fading simulator. Not only does the simulator do simple notch sweeps, it also makes two automatic swept signature measurements.

## Low distortion

To properly stress a radio receiver with multipath distortion, no other types of distortion should be introduced. The 11757B typically has less than -50 dBc intermodulation distortion products, so you know the radio's performance is due to multipath distortion and not to distortion introduced by the simulator.

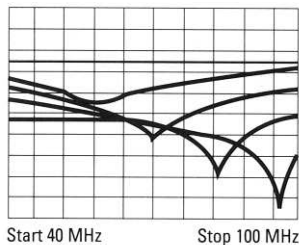

The notch depth, position and flat fade depth can be swept independently or simultaneously to test a radio under dynamic multipath fading.



The flexibility of the 11757B allows you to conveniently record data with the internal printer or use an HP ThinkJet printer.

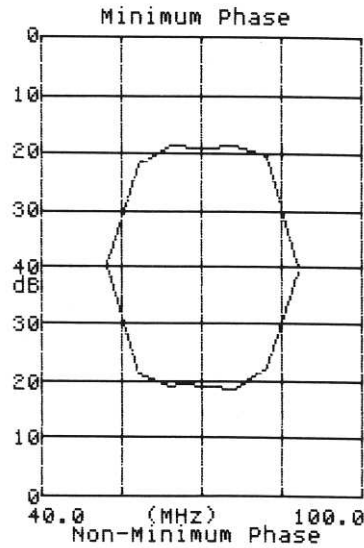

The first dynamic measurement provides an M-Curve type plot made with a sinusoidally varying notch per IEC Draft Publication 835. This technique allows comparison of the relative outage regions for different notch deviations and rates.

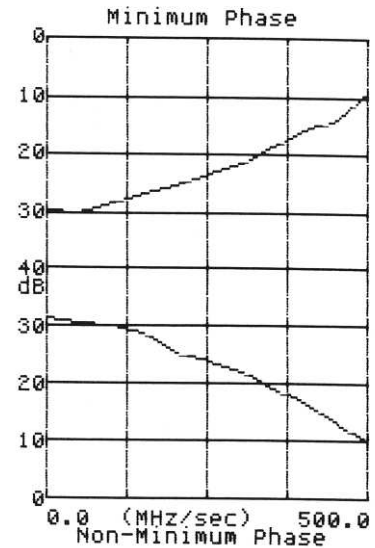

The second dynamic signature clearly shows the notch speed at which the equalizers become sensitive to a notch sweeping across the entire channel bandwidth at various notch depths.

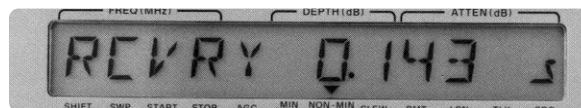

Severe dispersive fading can cause a receiver to completely lose synchronization and frame lock. The 11757B measures the time for a radio to recover from both a faded and non-faded condition.

# Increase radio uptime by checking your radio before fade season begins

Make sure you get the radio performance that you pay for by verifying the manufacturer's quoted radio performance during installation and commissioning. The 11757B offers the same multipath fading capability manufacturers use to test their radios. Now, the same M-Curve signature measurement can be made in the field.

Instead of waiting for adverse weather conditions to cause multipath fading, let the 11757B simulate the impairments on your timetable – and approach the next fade season with confidence. Eliminate expensive radio downtime, by making the M-Curve signature measurement a regular part of the maintenance schedule before fading happens.

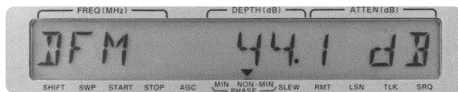

Dispersive fade margin provides a benchmark measure of the outage of a radio due to multipath fading. The 11757B calculates it with every signature measurement per Bellcore technical advisory, TA-TSY-000752.

Several features make the 11757B ideal for field service and maintenance:

- Economical price
- Fast measurements
- Internal printer
- Masks for pass/fail testing
- Easy set-up
- Rugged, portable package

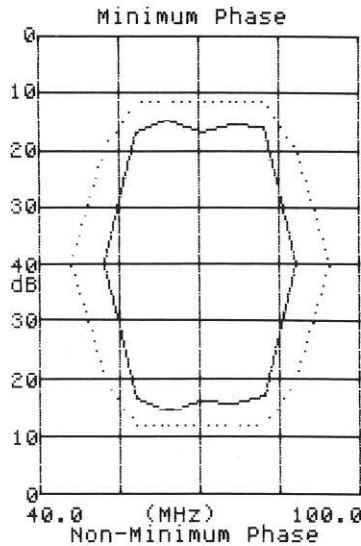

Fade Margin: 44.1dB  
Test Mask: PASSED

Save time by using the 11757B's pass/fail test masks to compare measured results with the manufacturer's specifications.

It's easy to log data and look for radio degradations over time because the built-in printer provides hard copy results of both the signature plot and the tabular data. All of the important measurement parameters and a time /date stamp are printed out as well.

11757B MULTIPATH FADING  
SIMULATOR/SIGNATURE  
TEST SET

Date: 31 Jan 1991  
Time: 11:38:30

Radio Type:

Operator:

Comments:

## RESULTS

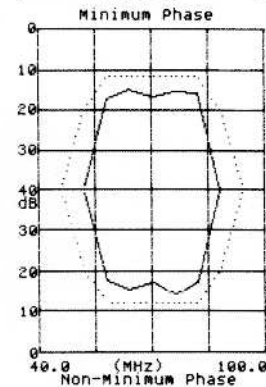

Fade Margin: 44.1dB  
Test Mask: PASSED

## DATA

FREQ (MHz)	DEPTH (dB)	MASK (dB)
40.0	--	40.0
46.0	--	40.0
52.0	39.0	20.0
58.0	17.3	12.0
64.0	15.3	12.0
70.0	16.9	12.0
76.0	15.7	12.0
82.0	16.4	12.0
88.0	40.0	20.0
94.0	--	40.0
100.0	--	40.0

FREQ (MHz)	DEPTH (dB)	MASK (dB)
40.0	--	40.0
46.0	--	40.0
52.0	39.2	20.0
58.0	17.6	12.0
64.0	15.3	12.0
70.0	17.0	12.0
76.0	14.9	12.0
82.0	17.1	12.0
88.0	39.7	20.0
94.0	--	40.0
100.0	--	40.0

## PREVIEW

### MEASUREMENT SETUP

SIGNATURE: Static-M  
STOP CRITERIA: 10E-3  
ERROR COUNT: 1024  
CENTER FREQ: 70MHz  
SPAN FREQ: 60MHz  
PHASE: Both  
DATA POINTS: 11

### RADIO SETUP

BIT RATE: 45E6  
ERROR TERM: ECL/75  
ERROR POLARITY: Pos  
SCALE FACTOR: 100  
AGC: On  
AGC FREQUENCY: 70MHz  
AGC BANDWIDTH: 30MHz

### OTHER SETUP

DELAY: 6.3ns  
TEST MASK: On

## Easy set-up

Field test procedures are short and easy to follow when you use the store/recall registers. Setting up a measurement for the first time is equally easy. Parameters are separate into radio-specific and measurement-specific settings. For a quick verification of settings before the measurement begins, the preview key automatically prints out all relevant measurement settings.

## Speed and accuracy

The 11757B optimizes the static M-Curve signature for speed without sacrificing accuracy. Because some tradeoff for speed and accuracy does exist, the 11757B gives maximum flexibility by letting you choose the number of errors to count for each measurement. This means that both time-critical and accuracy-critical measurements can be made with the same test set.

## Error Counter

One of the main reasons for the 11757B's measurement speed is the internal error counter. Bit error rate is monitored in real-time during the search algorithm instead of waiting for a BERT's gate time. This flexible counter accommodates both TTL and ECL levels, and is designed to work with outputs from either a bit-error-rate test set or the radio itself. A selectable scaling factor allows for variations in error pulse definitions between radios.

## Arbitrary fading event

Realistic fading tends to be random and sporadic, not like the fixed and swept notches that fade simulators traditionally produce. The 11757B simulates realistic fading. By initially loading statistical or measured fading data into the 11757B's nonvolatile memory using a controller, up to 10 complex fading even simulations are possible. With this arbitrary fading event mode, the simulator can stress radios in extremely lifelike ways and in much shorter times than actual field tests.

## Auxiliary output

An auxiliary output is available on the rear panel. This is identical to the front panel output and is useful for monitoring signal power or viewing the signal on a spectrum analyzer. It can also be used as a second faded channel to compare two systems under identical conditions.

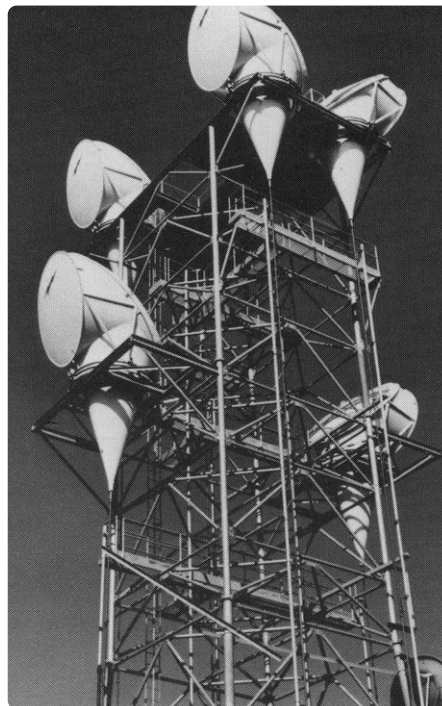

**The 11757B has been specifically designed for field service applications where a portable, lightweight, and rugged package is critical.**

# 11757B multipath fading simulator/ signature test set specifications

## Warranted specifications

Warranted specifications are for 15° to 35° C after a 15 minute warm-up period and notch frequencies 70 MHz  $\pm$ 20 MHz or 140 MHz  $\pm$ 20 MHz except where noted.

### Notch frequency

#### Ranges:

**Standard:** 40 MHz to 100 MHz

**Option 140:** 110 MHz to 170 MHz (90 MHz to 190 MHz availability to be determined)

**Option 147:** 40 MHz to 100 MHz and 110 MHz to 170 MHz (90 MHz to 190 MHz availability to be determined)

**Resolution:** 0.1 MHz

#### Accuracy (measured at 20 dB notch depth):

$\pm$ 0.3 MHz in 70 MHz band

$\pm$ 0.4 MHz in 140 MHz band

#### Typical notch frequency accuracy (at 25° C)

**Absolute accuracy:**  $\pm$ 0.15 MHz

**Relative accuracy:**  $\pm$ 0.8% per change in frequency or 0.30 MHz, whichever is greater

**Repeatability and 24 hour drive (at 25°C):**  $\pm$ 0.03 MHz

#### Notch Depth

**Range:** 0 to 40 dB

**Resolution:** 0.1 dB

#### Accuracy:

Notch

Depth

20 dB  $\pm$ 0.75 dB

30 dB  $\pm$ 1.50 dB

40 dB  $\pm$ 3.00 dB

#### Typical notch depth accuracy

##### Accuracy:

Notch depth	at 25° C	15° C to 35° C	Repeatability and 24 hour drift (at 25° C)
20 dB	$\pm$ 0.2dB	$\pm$ 0.50 dB	$\pm$ 0.03 dB
30 dB	$\pm$ 0.3 dB	$\pm$ 0.75 dB	$\pm$ 0.10 dB
40 dB	$\pm$ 1.0 dB	$\pm$ 2.00 dB	$\pm$ 0.30 dB

#### Flat fade

**Gain range:** 0 to 12 dB

**Attenuation range:** 0 to 50 dB

**Resolution:** 0.1 dB

**Accuracy (from 0 dB to 30 dB flat fade):**  $\pm$ 2 dB

**Typical gain/flat attenuation (at 25° C)**

**Accuracy (from 0 dB to 30 dB flat fade measured at 70 MHz and 140 MHz):**

$\pm$ 0.4 dB

## Supplemental characteristics

Typical, non-warranted characteristics, measured at 25° C with notch frequencies 70 MHz ±20 MHz or 140 MHz ±20 MHz except where noted.

### *Signature types*

Static M-Curve, Dynamic M-Curve, Dynamic S-Curve, Hysteresis

### *Recovery time*

**Range:** 5 msec to 5 sec

**Accuracy:** 1 msec

**Resolution:** 1 msec

### *Setting ranges*

**Bit rate:** 2.00 MHz to 200.00 MHz

**BER threshold:** 1E-3, 3E-4, 1E-4, 3E-5, 1E-5, 1E-6

**Dynamic S rates:** 1 MHz/sec to 6000 MHz/sec

**Dynamic M rates:** 10, 20, 100, 300, 600, 1200 MHz/sec

**Dynamic M deviations (plus and minus):** 1, 2, 3, 5, 10, 20 MHz

**Scale factor (pulse to error ratio):** 1.0 to 100.0

**Error bits (number of errors counted for near-threshold BER measurement):**

2<sup>n</sup> counts where 0 ≤ n ≤ 15

**Maximum number of data points/phase per measurement:**

Static M-Curve – 100

Dynamic M-Curve – 100

Dynamic S-Curve – 100

Hysteresis – 200

**Measurement speed: (static M-Curve, one phase, 10 data points, BER = 1E-3, bit rate = 44.7 Mb/s (DS3), error bits = 2048):** <1 minute

### *Error pulse input*

**Termination:** ECL/10k Ω, ECL/75 Ω, TTL/10k Ω, or TTL/75 Ω

**Minimum pulse width:** 2.5 nsec ECL, 10 nsec TTL

**Minimum time between counted error bits:** 25 ns

### *Alarm input*

**Termination:** TTL/10k Ω positive or negative edge triggered

**Minimum pulse width:** 10 nsec

## **Sweep**

**Range:** 10 msec to 99.9 sec

**Resolution:** 0.01 sec

**Maximum slew rate:** Notch frequency: 6000 MHz/sec  
Notch depth: 4500 dB/sec  
Gain/attenuation: 6500 dB/sec

### *Automatic Gain Control (AGC)*

Maintains constant average gain for notch depth up to 40 dB over 1.0 MHz to 40 MHz bandwidths.

### *Simulated variable delay*

**Range:** 2 ns to 25 ns

**Resolution:** 0.1 ns

### *Internal fading event memory*

**Number of data sets:** 2000

(Each data set contains notch frequency, notch depth, minimum/non minimum phase, flat attenuation and sweep time per data set)

**Number of fade event sequences:** 10

**Noise figure (measured with gain = 12 dB):**  $\leq 15$  dB

### **Three-tone intermodulation distortion**

(measured at  $-4$ dBm input power with gain  $\leq 0$  dB)

70 MHz band                      140 MHz band

$\leq 50$  dBc                           $\leq 47$  dBc

**Input frequency range (3 dB):**  $\leq 5$  MHz to  $\geq 300$  MHz

### *Frequency response*

**Amplitude variation:**  $< \pm 0.2$  dB

**Group delay variation:**  $\leq \pm 1$  ns

(measured with 0 dB notch depth,  $\pm 20$  MHz bandwidth)

### *Power consumption*

**Line voltage:** 100, 115, 120 or 220, 230, 240  $\pm 10\%$

**Power dissipation:**  $< 200$  VA

### *General*

**Weight:** 9 kg (20 lbs)

**Size:** 213 mm (8.4") H x 366 mm (14.4") W x 460 mm (18.1") D

### *Ordering information*

11757B multipath fading simulator/signature test set

Option 001 Delete printer and signature capability

Option 140 140 MHz IF coverage instead of 70 MHz

Option 147 Both 70 MHz and 140 MHz coverage

Option 915 Add service manual

Option 916 Extra operating manual

Option H02 Higher input/output power capability (+4 dBm)

Option W30 Additional 2-year warranty

### *Recommended accessories*

**Synchronization cable:** P/N 11757-60027

(one required per pair on instruments for synchronization)

**50 Ohm to 75 Ohm adapter:** 11694A (three required per instrument)

**Soft carrying case:** P/N 1540-1130

**Black print thermal paper:** HP82175A

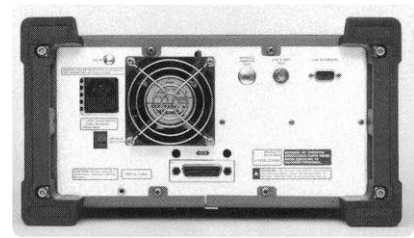

Rear panel.

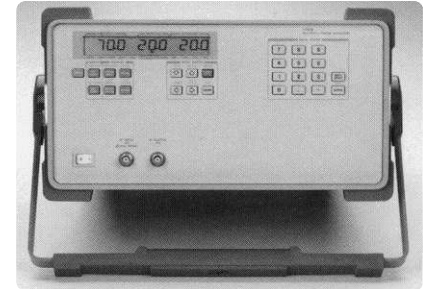

11757B Option 001 deletes printer and signature capability.

# Agilent satisfies your test and measurement needs for digital microwave radio

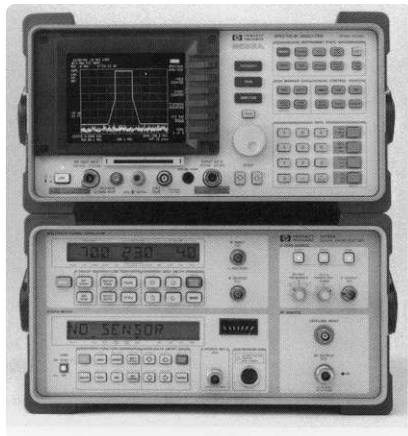
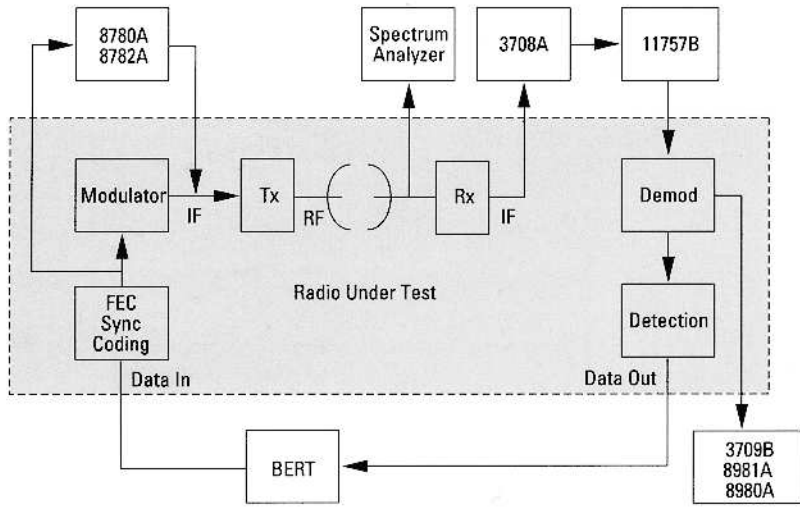

**The 11758U provides a complete digital microwave radio maintenance solution. In addition to a multipath fading simulator, it contains a spectrum analyzer, power meter, RF/MW source, and multitone IF source.**

## Agilent instruments commonly used to test DMR:

8782A, 8780A vector signal generator – replaces your modulator with a calibrated standard.

3708A noise and interference test set – establishes accurate and repeatable C/N and C/I levels.

11757B multipath fading simulator – simulates the effects of multipath propagation.

3709B constellation analyzer and 8980A/8981A vector analyzers – diagnose radio performance by viewing eye diagrams and constellations.

Spectrum analyzers – Agilent has a complete line of microwave spectrum analyzers including the 8562B and the 8593A which support the digital radio personality.

Bit error rate tester – high performance error analysis: 3789B DS3 transmission test set, 3764A digital transmission analyzer, 37721 digital transmission analyzer.

11758U digital radio test system – a complete digital microwave radio maintenance solution.

### **Agilent Technologies' Test and Measurement Support, Services, and Assistance**

Agilent Technologies aims to maximize the value you receive, while minimizing your risk and problems. We strive to ensure that you get the test and measurement capabilities you paid for and obtain the support you need. Our extensive support resources and services can help you choose the right Agilent products for your applications and apply them successfully. Every instrument and system we sell has a global warranty. Support is available for at least five years beyond the production life of the product. Two concepts underlie Agilent's overall support policy: "Our Promise" and "Your Advantage."

#### **Our Promise**

Our Promise means your Agilent test and measurement equipment will meet its advertised performance and functionality. When you are choosing new equipment, we will help you with product information, including realistic performance specifications and practical recommendations from experienced test engineers. When you use Agilent equipment, we can verify that it works properly, help with product operation, and provide basic measurement assistance for the use of specified capabilities, at no extra cost upon request. Many self-help tools are available.

#### **Your Advantage**

Your Advantage means that Agilent offers a wide range of additional expert test and measurement services, which you can purchase according to your unique technical and business needs. Solve problems efficiently and gain a competitive edge by contracting with us for calibration, extra-cost upgrades, out-of-warranty repairs, and on-site education and training, as well as design, system integration, project management, and other professional engineering services. Experienced Agilent engineers and technicians worldwide can help you maximize your productivity, optimize the return on investment of your Agilent instruments and systems, and obtain dependable measurement accuracy for the life of those products.

**By internet, phone, or fax, get assistance with all your test and measurement needs.**

#### **Online assistance:**

**[www.agilent.com/find/assist](http://www.agilent.com/find/assist)**

#### **Phone or Fax**

United States:

(tel) 1 800 452 4844

Canada:

(tel) 1 877 894 4414

(fax) (905) 282 6495

China:

(tel) 800 810 0189

(fax) 1 0800 650 0121

Europe:

(tel) (31 20) 547 2323

(fax) (31 20) 547 2390

Japan:

(tel) (81) 426 56 7832

(fax) (81) 426 56 7840

Korea:

(tel) (82 2) 2004 5004

(fax) (82 2) 2004 5115

Latin America:

(tel) (305) 269 7500

(fax) (305) 269 7599

Taiwan:

(tel) 080 004 7866

(fax) (886 2) 2545 6723

Other Asia Pacific Countries:

(tel) (65) 375 8100

(fax) (65) 836 0252

Email: [tm\\_asia@agilent.com](mailto:tm_asia@agilent.com)

Product specifications and descriptions in this document subject to change without notice.

© Agilent Technologies, Inc. 2001

Printed in USA, August 20, 2001

5091-1052EN

