

Agilent E8408A VXI Mainframe, C-Size, 4-Slot, 175 Watt

Data Sheet

- 4-Slot, C-size
- Agilent's lowest-priced VXI C-size mainframe
- Small size/light weight opens new applications for VXI
- Basic mainframe monitoring increases measurement confidence
- Efficient, quiet cooling improves performance
- Compliant with VXIbus Specifications

Description

The E8408A, Agilent's **4-slot C-size VXI mainframe**, is priced well below other Agilent VXI C-size mainframes. Its low price brings down the cost of test, especially when combined with Agilent's multi-function VXI M-Modules and data acquisition modules.

The E8408A is Agilent's smallest and lightest-weight C-size mainframe. Its small size saves system rack space. Small size and light weight make the E8408A transportable and suitable for many data acquisition and field service applications.

The E8408A offers mainframe monitoring, quiet efficient cooling, and 175 watts of usable power. Front panel monitor lights give up-to-the-moment indication that power supply and fan are operating and that the internal temperature is OK. A two-speed fan provides quiet, powerful cooling.

Refer to the Agilent Technologies Website for instrument driver availability and downloading instructions, as well as for recent product updates, if applicable.



Agilent E8408A with modules installed



Visit Agilent Technologies' worldwide websites (<http://www.agilent.com/find/vxi> or <http://www.agilent.com/find/tmdir>) to review the following E8408A example applications:

- Appliance manufacture
- Battery manufacture
- Cable and wire test
- Canning process characterization
- Crystal oscillator manufacture
- Design verification using environmental chambers
- Energy conservation
- Elevator test
- Race car test
- Switch box in Electronic Functional Test
- Wastewater treatment/test

175 Watts Usable Power

The E8408A provides 175 watts usable power. This is adequate to power the vast majority of Agilent VXI modules.

Superior Cooling

The E8408A's innovative mechanical design provides extremely quiet and efficient cooling for the power supply and modules. Carefully engineered airflow provides excellent cooling with minimum acoustic noise.

A two-speed cooling fan provides reliable cooling of the power supply and modules. The fan operates in either Variable (automatically controlled) or Full Speed mode. A two-position switch on the mainframe's front panel controls the speed mode. Full Speed mode is recommended for maximum cooling when acoustic noise is not a big concern. In Variable Speed mode, the fan speed is controlled automatically as a function of temperature rise in the mainframe and ambient temperature. Variable Speed mode allows the quietest operation while providing sufficient power supply and module cooling.

Airflow enters the mainframe rear panel, flows through the power supply, fan and modules and exhausts out the left side (as viewed from the front with the E8408A in horizontal position). This allows mainframes to be stacked or rack-mounted directly on top of one another.

At-a-Glance Confidence in Operation

The E8408A front panel indicator lights give up-to-the-moment visual indication that power supply voltages are operational, the power supply temperature is within limits, and the fan is operational.

Improved, Highly Reliable Backplane Design

The backplane features solid state automatic daisy-chain jumpering for the VMEbus grant and interrupt acknowledge lines, eliminating the need for hand selection of switch settings. Full differential distribution of the CLK10 signal is provided on the backplane. This minimizes jitter and skew, providing a clean timing source for VXI instrument modules. The surface mount backplane improves both reliability and stripline signal performance.

Agilent generates SYSRESET and ACFAIL on the backplane. This is necessary for full compliance with the VXI Specification, but is not generally implemented by other manufacturers.

Easy Maintenance Power Supply

Convenient access to the power supply and cooling fan is provided through the mainframe's rear panel. A replacement power supply and fan can be installed without removing the mainframe from your rack. The power supply's plug-in design makes replacement easy.

Accessories and Configurations

Backplane Connector Shields Kit

The E8408A Opt 918 improves ground connections between VXI modules and the E8408A backplane. A few Agilent VXI modules require these shields to comply with EMC EN55011 and CISPR11. (The vast majority of Agilent VXI modules do not require these shields.) Note that the shields are only useful if VXI modules include contacts that conform to VXI Spec. B.7.2.3.

Rack Mount/Cable Route Kit

The E8397A Rack Mount Adapter Kit allows the E8408A to be flush-mounted or recess-mounted up to 8 inches in one-inch increments. In addition, the rack mount kit includes a 1.125-inch-wide cable route on the mainframe's right side, plus stick-on labels for use when the mainframe is mounted in a horizontal position. To mount the E8408A in Agilent rack cabinets, order the E8397A Rack Mount Cable Route Adapter Kit and either the E3663AC Support Rail Kit or 1494-0413 Rack Slide Kit. The 1494-0413 Rack Slide Kit can be mounted in non-Agilent rack cabinets using 1494-0061 End Brackets.

EMC Filler Panel (1-slot wide)

The Agilent E8400-60202 filler panel (1-slot wide) provides continuous EMC connection across the mainframe front opening. This helps reduce radiated emissions and increases ESD immunity. All Agilent VXI modules include EMC contacts to adjacent slots.

VXI Slot Filler Panel (1-slot wide)

The E8400-44305 VXI Slot Filler Panel is 1-slot wide and is used to cover unused slots, providing a smooth appearance and preventing access. In addition to the cosmetic and safety value, the slot filler panel suppresses acoustic noise and improves airflow. The E8400-44305 does not include EMC contacts.

Air Flow Restrictor (1-slot)

The one-slot E8400-80917 Air Flow Restrictor blocks airflow in one empty slot.

Intermodule Chassis Shield Kit (1-slot wide)

The E8400-80919 Chassis Shield Kit (1-slot wide) provides additional shielding between noisy modules. These shields are relatively easy to install.

Documentation

Mainframe documentation consists of a User/Service Manual which describes electrical and mechanical aspects of the mainframe and accessories. The manual is included on Agilent's Universal Instrument Drivers CD-ROM supplied with the mainframe and is also available on Agilent's Website. A printed copy of the manual is also included.

Warranty

Agilent Technologies provides a standard 3-year return-to-Agilent warranty on this mainframe. E8408A Opt. W01 converts the standard warranty to 1-year On-Site.

Product Specifications

Mechanical

	Without bumpers
Mainframe height: (horizontal orientation)	133 mm (5.25 in.) (3 EIA rack units)
Mainframe width:	362 mm (14.3 in.)
Mainframe depth:	540 mm (21.3 in.)
Mainframe weight:	8.6 kg (19 lbs.)
	With bumpers
Mainframe height: (horizontal orientation)	152 mm (6.0 in.) (3 EIA rack units)
Mainframe width:	388 mm (15.3 in.)
Mainframe depth:	548 mm (21.6 in.)
Mainframe weight:	9.1 kg (20 lbs.)

Available Current Voltage	Peak Current I_{MP}^1 (Amps) From 0 - 55° C: ²	Dynamic Current I_{MD}^1 (Amps) From 0- 55° C: ³
+5V: ^{4, 5}	17 A	2.5 A
+12V: ⁶	2.7 A	1.0 A
-12V: ⁶	2 A	0.8 A
+24V:	2 A	1.0 A
-24V:	2 A	1.0 A
-5.2V: ⁵	2 A	1.0 A
-2V:	2 A	1.0 A

1. Specifications apply at the mainframe backplane, 0 - 55° C.

2. I_{MP} = Rated mainframe peak dc output current as defined by the VXIbus Specification.

3. I_{MD} = Rated mainframe peak-to-peak dynamic current as defined in the VXIbus Specification by a current vs. frequency curve.

4. +5V must have a 1.0 A minimum load for other supplies to be in regulation specification.

5. Maximum +5V current can be increased if -5.2V load is less than 2.0 A maximum or -2V load is less than 2.0 A maximum. Maximum = 17.0 A + 1.2*(2.0 A - Load on -5.2V) + 0.4*(2.0 A - Load on -2V).

6. Maximum +12V current can be increased if -12V load is less than 2.0 A maximum. Maximum = 2.7 A + 1.2*(2.0 A - Load on -12V).

Power

Temperature range:	0 to 40° C	40 to 50° C	50 to 55° C
Usable power (90-264 Vac):	175 W	150 W	125 W

Power Input

Input voltage/frequency:	90 Vac min. - 140 Vac max.: 47 Hz min. - 440 Hz max. 90 Vac min. - 264 Vac max.: 47 Hz min. - 66 Hz max. 280 VA max.
---------------------------------	--

Inrush current:

At input voltage 132 Vac:	<35 A typical
At input voltage 264 Vac:	<75 A typical

Power Switch

On/Standby switch on front panel.

Power Supply Protection

All voltages are protected from over-temperature, over-voltage, short-to-ground and short-to-other-output.

Acoustic Noise

(Sound power at bystander position one meter in front of mainframe)

High-speed fan:	<40 dBA
Variable fan on low speed:	<30 dBA

Shielding

Front panel EMC gasketing:	Front panel gasketing provided per VXI Rev. 1.4, B.7.2.3
Backplane shielding:	Backplane connector shields per VXI Rev. 1.4, B.7.2.3
Intermodule chassis shielding:	Intermodule chassis shields per VXI Rev. 1.4, B.7.3.4

Airflow

Airflow is routed into the mainframe rear and exhausted out the left side (viewed from the front with E8408A in horizontal position). When the mainframe is rack-mounted, allow 50 mm of clearance at the rear and left side for proper air flow.

Fan Speed

(Cooling Mode, High or Variable set by front panel switch)

High fan speed mode:	Maximum airflow all the time
Variable fan speed mode:	Fan speed changes between high and low as a function of ambient and power supply temperature.

Agilent E8408A Cooling Specification Chart

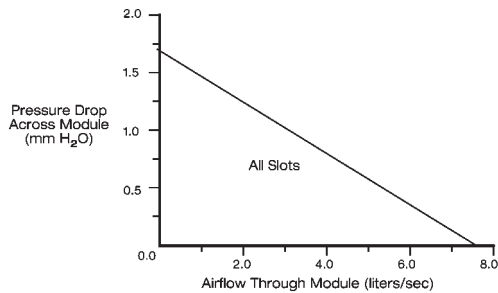

VXI-8 Specification Draft 2.0. Fixture revision 1.7.

- VXI-8 Standard Modules installed in all other slots.
- Measurements taken at 1,500 m altitude.

Backplane Specifications

- Solid-state automatic daisy-chain jumpering for BUS GRANT and IACK signals.
- Full differential distribution of CLK10.
- ACFAIL* and SYSRESET* in full compliance with the VMEbus and VXIbus Specifications.
- Surface mount construction and no sockets for maximum reliability.

Mainframe Monitor Specifications

Indicators: (front panel)	Power supply output voltages monitor Power supply temperature monitor Fan status monitor
Switches: (front panel)	On/Standby Fan Mode: Switches fan between Full Speed and Variable Speed modes

Environmental

Temperature

Operating temperature range:	0° C to +55° C
Storage temperature range:	-40° C to +70° C

Humidity (non-condensing)

Operating humidity range:	Up to 95% RH from 0° C to +40° C, Up to 65% RH from +40° C to +55° C
Storage humidity range:	Up to 95% RH from 0° C to +55° C, Up to 90% RH from +55° C to +65° C

Altitude: Up to 3,000 m

Standards Compliance

100% compatible with the VXIbus Specification Rev 1.4.

Repair

MTTR = Mean Time to Repair

Repair

MTTR = Mean Time to Repair

MTTR, power supply: <20 min. (w/mainframe and modules fully installed in rack)

MTTR, fan: <30 min. (w/mainframe and modules fully installed in rack)

General Specifications

VXI Characteristics

VXI device type:	Mainframe
Data transfer bus:	All per VXIbus Specification, Rev 1.4
Size:	C
Slots:	4 available
Connectors:	P1/P2
Shared memory:	n/a
VXI buses:	All per VXIbus Specification, Rev 1.4

Configuration Guidelines

The following Agilent VXI modules are not supported by the E8408A:

- E9850/51A VXI Embedded PC Controller
- E1430A 10 MSa/s ADC
- E1437A 20 MSa/s ADC
- E1445A Arbitrary Function Generator
- E1450A/1A/2A Timing & I/O Modules
- E1740A Time Interval Analyzer

Ordering Information

Description	Product No.
4-Slot, C-size, 175 W VXI Mainframe. (includes front panel indicators, protective bumpers, & carrying handle)	E8408A
Installed Backplane Connector Shields	E8408A 80900
Rack Mount/Cable Route Adapter Kit	E8397A
User/Service Manual (if ordered separately)	E8408-90001
Airflow Restrictor (1-slot)	E8400-60007
Intermodule Chassis Shield Kit	E8400-80919
EMC Filler Panel (1-slot)	E8400-60202
VXI Slot Filler Panel (1-slot)	E8400-44305
Field Installation Kit for Rack Mount/Cable Route Adapter	E8408-80923
Support Rail Kit for VXI <i>plug&play</i> (VPP-8)	
Rack Mount Kit (used w/E8397A)	E3663AC
Rack Slides to mount in Agilent rack cabinet (used w/E8397A)	1494-0413*
Replacement 175 W Power Supply Module	E8408-69005
Replacement Fan Assy	E8408-68500

***Note:** For customers with non-Agilent racks, you must also order 1494-0061 End Brackets to adapt 1494-0413 Rack Slides.

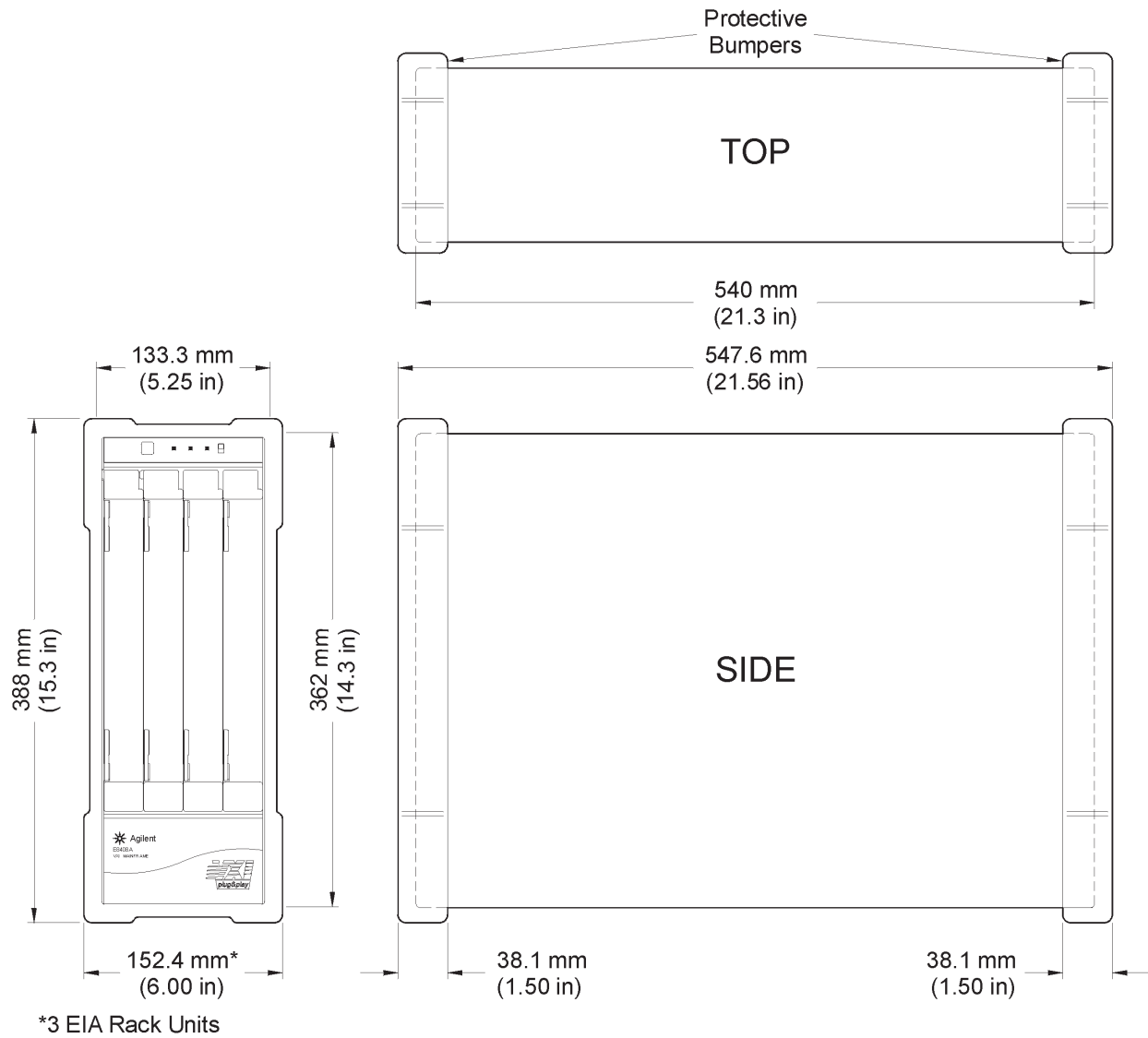

E8408A Mainframe Dimensions

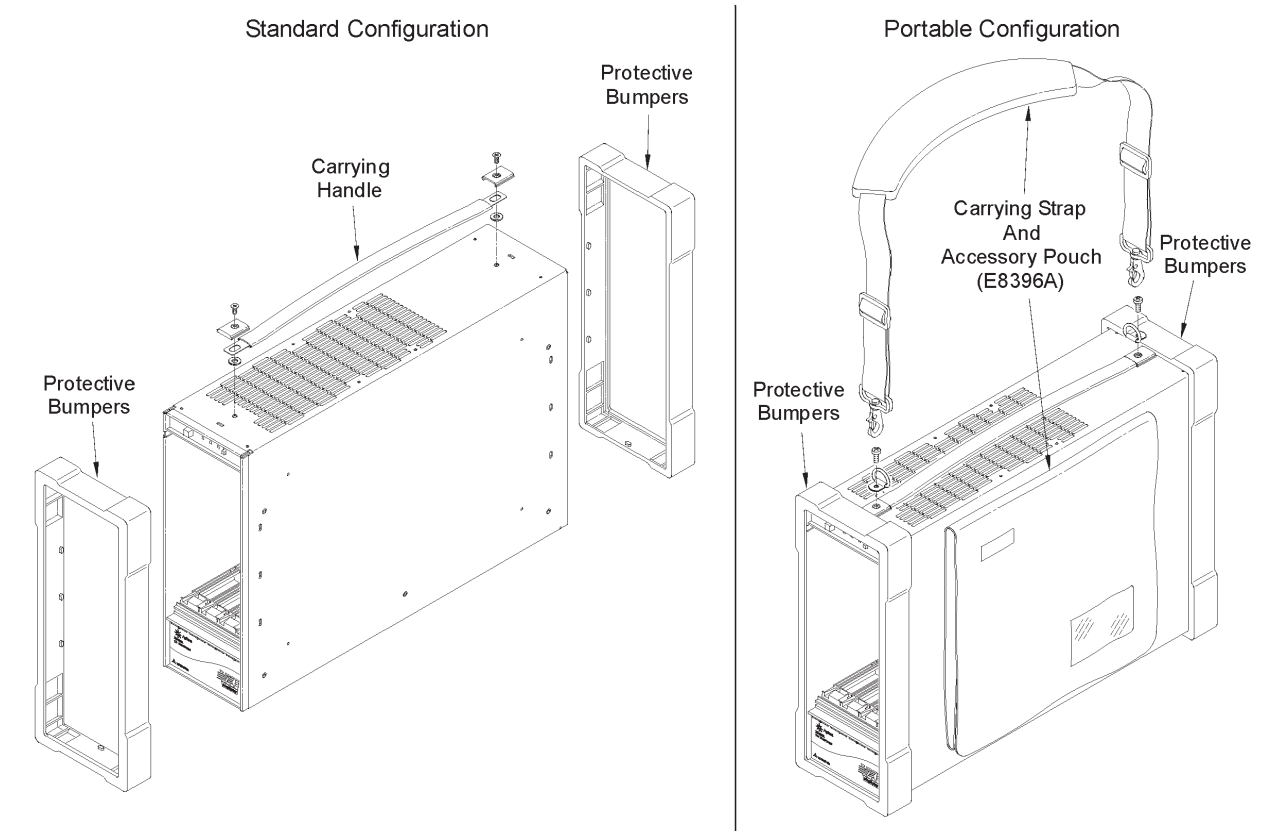

Rack Mount Configuration

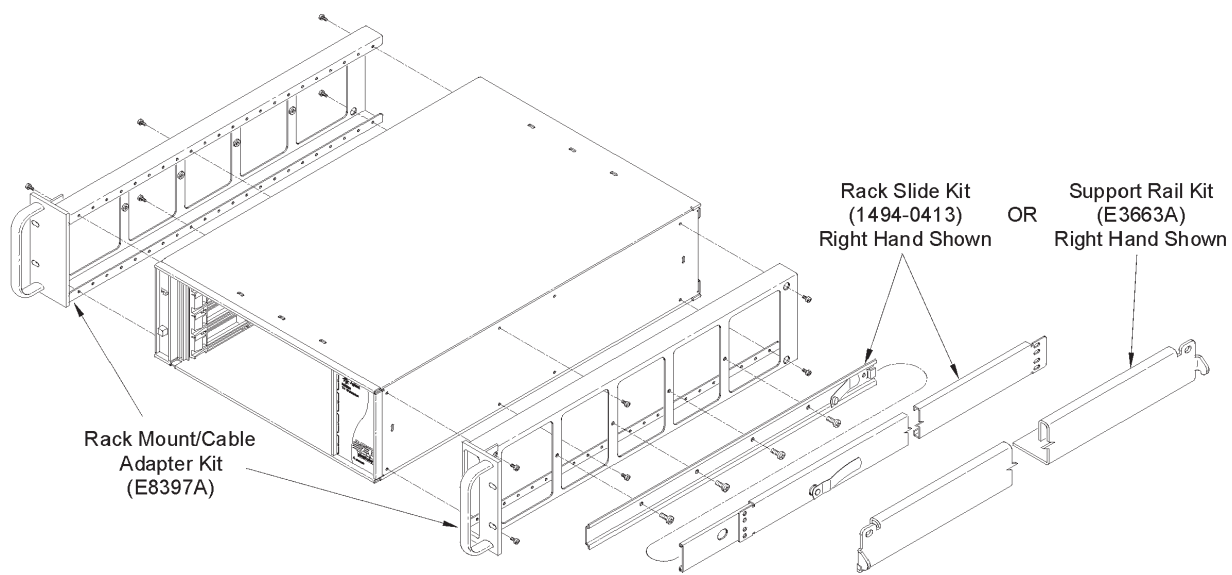

E8408 Mainframe Configurations/Options

Agilent Technologies' Test and Measurement Support, Services, and Assistance

Agilent Technologies aims to maximize the value you receive, while minimizing your risk and problems. We strive to ensure that you get the test and measurement capabilities you paid for and obtain the support you need. Our extensive support resources and services can help you choose the right Agilent products for your applications and apply them successfully. Every instrument and system we sell has a global warranty. Two concepts underlie Agilent's overall support policy: "Our Promise" and "Your Advantage."

Our Promise

Our Promise means your Agilent test and measurement equipment will meet its advertised performance and functionality. When you are choosing new equipment, we will help you with product information, including realistic performance specifications and practical recommendations from experienced test engineers. When you receive your new Agilent equipment, we can help verify that it works properly, and help with initial product operation.

Your Advantage

Your Advantage means that Agilent offers a wide range of additional expert test and measurement services, which you can purchase according to your unique technical and business needs. Solve problems efficiently and gain a competitive edge by contracting with us for calibration, extra-cost upgrades, out-of-warranty repairs, and onsite education and training, as well as design, system integration, project management, and other professional engineering services. Experienced Agilent engineers and technicians worldwide can help you maximize your productivity, optimize the return on investment of your Agilent instruments and systems, and obtain dependable measurement accuracy for the life of those products.



Agilent Email Updates

www.agilent.com/find/emailupdates

Get the latest information on the products and applications you select.

Agilent T&M Software and Connectivity

Agilent's Test and Measurement software and connectivity products, solutions and developer network allows you to take time out of connecting your instruments to your computer with tools based on PC standards, so you can focus on your tasks, not on your connections.

Visit www.agilent.com/find/connectivity for more information.

For more assistance with all your test and measurement needs or to find your local Agilent office go to www.agilent.com/find/assist

Product specifications and descriptions in this document subject to change without notice.

© Agilent Technologies, Inc. 2005
Printed in the USA May 1, 2005
5968-3564E



Agilent Technologies