

Agilent 8765F Coaxial Switch 75 ohm

Data Sheet

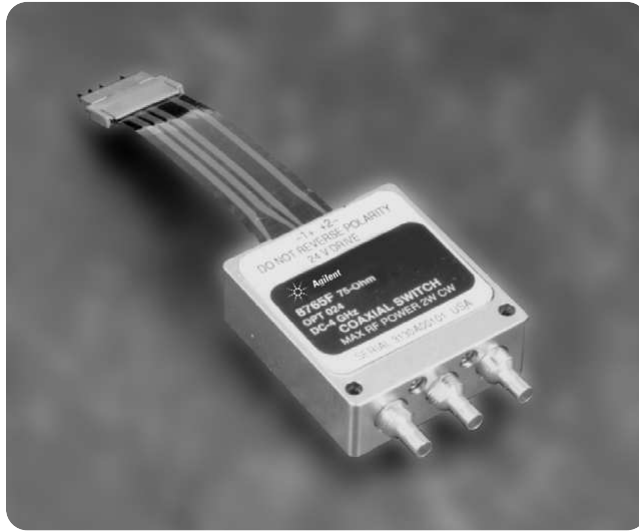

- **DC to 4 GHz**
- **Exceptional repeatability over 5 million cycle life**
- **Excellent isolation**

In applications such as production test, maintaining a calibration is critical in order to assure accurate reliable measurements AND to avoid frequent recalibration. Switch repeatability, especially in a test system switching interface, can contribute to test system uncertainty by adding random errors. Repeatability is controlled through a variety of factors including precise control of the switching structure and contact materials. The 8765F has a typical insertion loss repeatability, over 5 million cycles, of 0.03 dB at 25 °C.

Interfacing to the 8765F

The 8765F uses a mini 75 ohm SMB connector. This connector has the same physical dimensions as a 50 ohm SMB, but has been optimized for 75 ohms. Sources for connectors are listed at the end of this data sheet.

The 8765F brings a new standard of performance to 75 ohm coaxial components. Designed for ATE switching systems, the 8765F offers the performance being demanded by the cable television distribution equipment and communications equipment industries. It gives the ATE system designer for telecommunications and cable distribution equipment the tools to design high performance, reliable switching interfaces.

The 8765F uses a mini 75 ohm SMB connector for the coaxial interface. The mini 75 ohm SMB connector is designed to terminate RG-179 75 ohm

coaxial cable. The 8765F is designed to work in virtually any system by virtue of the variety of voltage options covering 4.5V to 32V dc available for activating the switch solenoids. While the standard configuration for the switch comes with a dc ribbon cable connector, solder terminals are also available as Option 8765F-3xx, where xx = 05, 10, 15, or 24.

As with its 50 ohm counterparts, the 8765A/B/C/D, the 8765F was designed for maximum dependability and performance. It has been designed to operate within its specifications for over 5 million cycles.



Agilent Technologies

Driving the 8765F

The 8765 switch family is available with two methods for connecting to the DC control circuitry. The standard switch comes with a ribbon cable terminated with a single in-line five position male connector with one pin removed. The user has the option of ordering solder terminals (Option 8765F-3xx) where they are required (Figures 7a and 7b). The 8765 switches have both sides of the switching solenoids available to the user. Typically, as is the case with the 8762 switches, the switching solenoids will have a common positive terminal or a common ground. By making both sides of each coil available, users can select the DC drive method that best suits their needs. The suggested methods are:

- *Common negative drive*
- *Common positive drive*
- *Polarity reversal drive*

Regardless of which method is chosen for switching, two conditions will always apply: 1) the switch is positive latching and 2) since there are no DC current interrupts, the supply may be continuous or may be switched off after the 15 ms switching time.

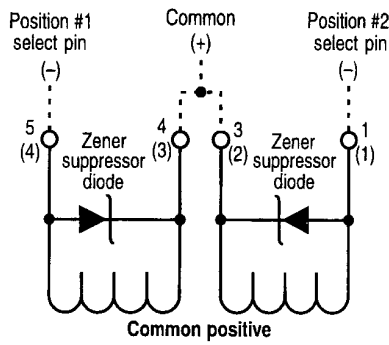

Figure 1

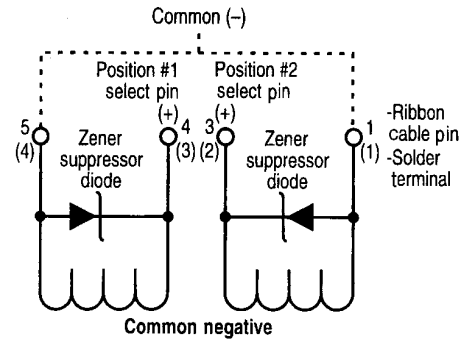

Figure 2

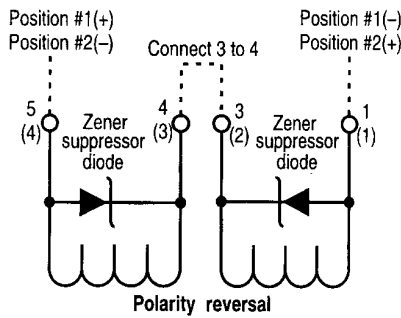

Figure 3

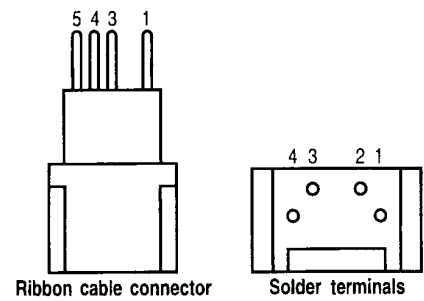

Figure 4

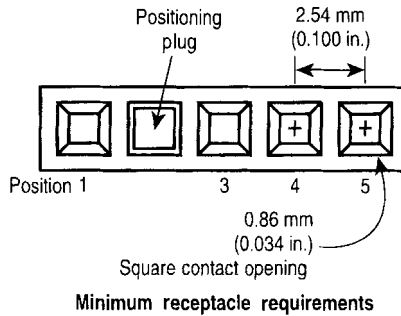

Figure 5

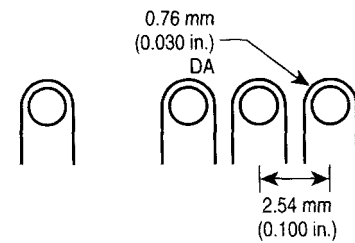

Figure 6

Common negative drive

With the common negative drive method, the two outside pins on the ribbon cable or the two outside terminals on the solder block are connected together to form a common negative or ground. Switching is then accomplished by applying the appropriate positive voltage to either of the inner pins or terminals (Figure 2).

Common positive drive

To drive the switch with a common positive arrangement, the two inner pins or terminals are tied together and then to a positive voltage. To effect switching, one of the two outer pins or terminals is brought to ground (Figure 1).

Polarity reversal drive

To drive the switch using a polarity reversal scheme, the two inner pins or terminals are tied together. The switch will complete a circuit between the two RF contacts on the side of the switch to which the negative or ground potential has been connected (Figure 3).

Interfacing the 8765

The 8765 family of switches is available with two DC control connection options. The standard switch is connected to the DC drive circuitry via a ribbon cable. Option 8765-3xx allows soldering wires between the control circuitry and the switch.

Ribbon cable

The kapton flex circuit ribbon cable on the standard switch Option 8765-005/010/015/024 is terminated to a single inline male polarized connector with four 0.64 mm (0.025 in.) square pin posts on 2.54 mm (0.100 in) centers. Position number 2 has been removed to facilitate polarization of the plug and receptacle (Figure 4).

To assist you in connecting your drive circuit to the switches ribbon cable connector, a six-foot long four-wire cable is included with every standard switch. The cable is terminated on one end with a 0.64 mm (0.025 in.) square pin receptacle. The five-position receptacle is polarized

to mate with the switches ribbon cable connector. The opposite end of the cable is left unterminated for connecting to your control circuits. The six-foot cable provides a quick and convenient way of connecting the switch to your control circuits for evaluation and low volume production. For high volume production a more convenient or more permanent connection may be suggested. Soldering the ribbon cable connector into a circuit board provides a reliable and rugged connection. Mating the ribbon cable connector to a PC board connector provides a quick to install and remove connection. The suggestions below are intended to provide minimum connection requirements. These suggestions are not endorsements or recommendations of one method over another. It is the responsibility of the user to determine the suitability for uses of any interconnect method for a particular application.

PC board connectors

PC board connectors are available in surface mount and solder pin styles and in horizontal and vertical orientations. This type of connector makes connection to and disconnection from the DC circuit quick and convenient. The connectors should be a minimum of five positions wide, and depending upon the number of switches to be connected can be any multiple of five positions (10, 15, 25, etc.). Single row or double row configurations can also be used to increase connector density. The contacts should accept 0.64 mm (0.025 in.) square pins set on 2.54 mm (0.100 in.) centers and up to 5.84 mm (0.230 in.) long. Use of a polarizing plug in the second position of each switch connection is recommended to help ensure proper orientation. Figure 5 shows a suggested receptacle dimension.

Soldered connections

The ends of the switch ribbon cable can also be soldered directly to a PC board. This method provides a semi-permanent connection that can withstand higher vibration environments than can the PC board connectors. Connection and disconnection of the switches requires soldering and more time and equipment than do PC board connectors. The PC board hole pattern should have the center lines of the through holes along a single axis separated by 2.54 mm \pm 0.08 mm. (0.100 in. \pm 0.003 in.). The suggested hole diameter for a 0.64 mm (0.025 in.) pin is 1.00 mm \pm 0.076 mm (0.040 in. \pm 0.003 in.). Omission of position 2 in the PC hole pattern is suggested to help prevent soldering the connector in the wrong orientation (see Figure 6).

Optional ribbon connector extension cables

Optional extension cables for the switch ribbon cable connector are available as Option 8765F-108 for an 8-inch extension and Option 8765F-116 for a 16-inch extension. The cables have male and female ends configured as indicated in Figure 4 “Ribbon cable connector” and Figure 5 “Minimum receptacle requirements.” These ribbon cables can be connected to the DC control circuitry with the same methods suggested above.

Optional solder terminals

Solder terminals in place of the ribbon cable for connecting to the dc control circuitry are available as Option 8765F-3xx. The four solder terminals provide access to both sides of each of the solenoids.

Easy GPIB programmability

The 8765F can be easily used in ATE systems with GPIB control using the 70611A or 87130A attenuator/switch drivers. The 70611A and 87130A use a pulse drive method, which allows them to drive up to 248 24V switches of either the non-interrupting type, such as the 8765F, or self-interrupting type, such as 8762s. All three drivers work with switches with 24Vdc solenoids, such as Option 8765F-024 for the 8765F.

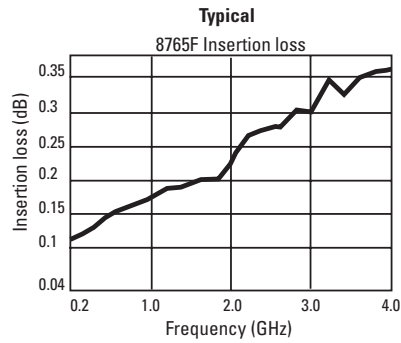

RF connectors

The 8765F uses the mini 75 ohm SMB connector introduced by E.F. Johnson in 1990. The mini 75 ohm SMB uses the same form factor as the 50 ohm version and the two will mate. It is important to note that these connectors will not mate to the larger diameter 75 ohm SMB or CONHEX connector. In order to make connections to different connector types, the following connector components are available from E.F. Johnson.

Specification table

Frequency range:	dc to 4 GHz
Insertion loss:	0.18 dB to 1 GHz
	0.24 dB to 2 GHz
	0.40 dB to 4 GHz
Isolation:	100 dB to 1 GHz
	90 dB to 4 GHz
SWR:	1.15 to 1 GHz
	1.20 to 4 GHz
Connectors:	Mini-SMB (m) 75 ohm
Repeatability (typical @ 25 °C)	< 0.03 dB for 5,000,000 cycles
Life:	> 5,000,000 cycles

Connectors for RG-1 79 and RG-1 87 from E. F. Johnson

Straight crimp plug	131-8403-001
Straight crimp bulkhead jack	131-8303-401
Right angle crimp plug	131-8403-101

Adapters from E.F. Johnson

Mini-SMB (m) to mini-SMB (m)	131-8901-801
Mini-SMB (f) to mini-SMB (f)	131-8901-811
Mini-SMB (m) to mini-SMB (f)	131-8901-821
Mini-SMB (f) to type N (m)	134-1069-001
Mini-SMB (m) to type N (m)	134-1069-011
Mini-SMB (f) to type N (f)	134-1069-021
Mini-SMB (m) to type N (f)	134-1069-031
Mini-SMB (m) to SMB (m) 50 ohm	134-1029-011

• **Typical characteristics are intended to provide information useful in applying the instrument by giving typical, but not warranted performance parameters.**

* **Specifications describe the instrument's warranted performance.**

Standard unit dimensions in millimeters (and inches)

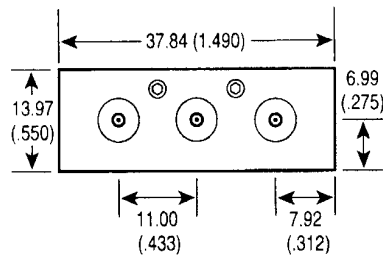
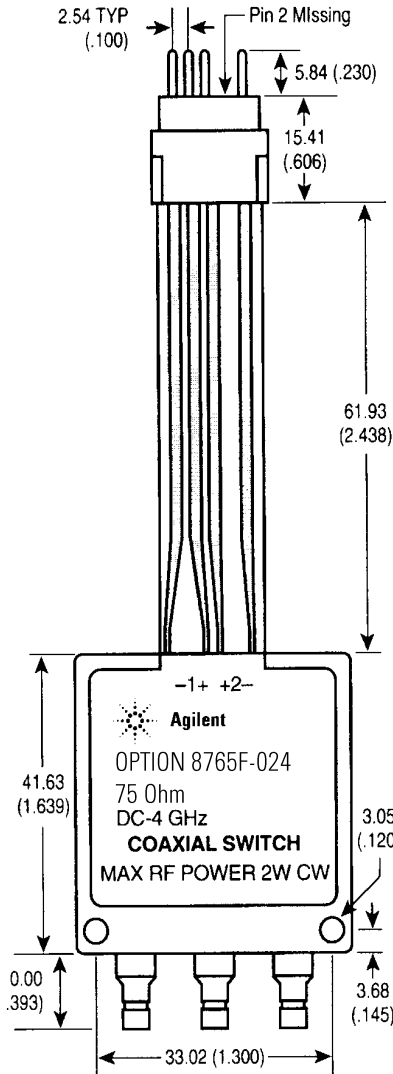

Figure 7a. 8765F with standard ribbon cable connector

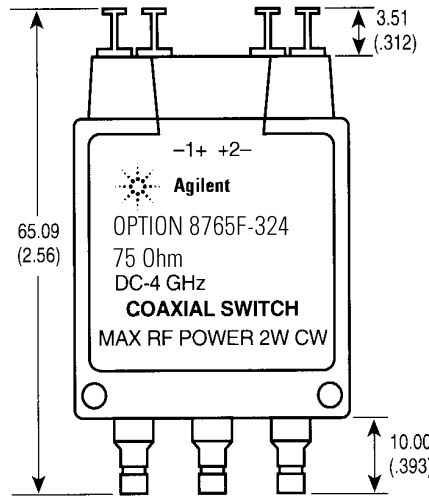
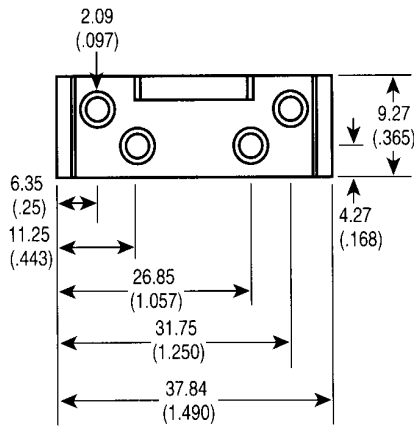

Figure 7b. Option 8765F-324 solder terminals

Environmental

Operating temperature:

-25 °C to 75 °C

Storage temperature:

-55 °C to 85 °C

Temperature cycling:

-55 °C to 85 °C,
10 cycles per MIL-STD 202F,
Method 107D, Condition A
(Modified)

Vibration

Operating:

7 g's: 5-2000 cycles @ 0.25"p-p

Survival:

20 g's; 20-2000 Hz @ 0.06"p-p
4 min/cycle, 4 cycles/axis

Random:

2.41 g(rms) 10 min/axis

Shock

Half sine: 500 g's @ 0.5 ms,

3 drops/direction, 18 total

Operating: 50 g's @ 6 ms,

6 directions

Moisture resistance:

65 °C, 95% RH, 10 days per
MIL-STD-202F, Method 106E

Altitude storage:

50,000 ft (15,240 m) per
MIL-STD-202F, Method 105C
Condition B

RFI: Per MIL-STD-461C, RE02,
Part 4

Electrostatic discharge:

25KV max

Operating life: 5,000,000 cycles

Ordering information

Switches must be ordered with a voltage option to be valid. Standard switches are equipped with ribbon cables terminated to a single in-line connector. All standard switches come with a six-foot cable with mating connector on one end to facilitate connection to the user's control circuitry.

Solder terminals

A solder terminal may be specified in place of the standard ribbon cable. Options 8765F-305/310/315, and 324, respectively. The solder terminal option does not include the extension cable and is not compatible with Options 8765F-108 or 8765F-116.

Accessories

For switching interfaces, the 87130A and 70611A are available for driving up to 248 switches or step attenuator sections. The 87130A is a full rack width switch controller/driver, while the 70611A is a 1/8 wide MMS module. Both these drivers use the IEEE 488.2 Standard Commands for Programmable Instrumentation for controlling and configuring the switches.

The 70611-60008 cable provides the means to adapt the four wire 8765 DC drive configuration to the three wire drive configuration of the 87130A and 70611A. In addition, the 84941A signal distribution board is available along with the 70611-60004 switch driver cable for the 87130A to externally mount switches. See the 87130A or 70611/2/3A/C data sheets for more information.

Microwave coaxial switch

8765F	DC to 4 GHz, 75 ohm
-------	---------------------

Options

To add options to a product, use the following scheme:

Model:	8765F
Model options:	8765F-opt#1 8765F-opt#2

Supply voltage (must choose one)

8765F-005	5V DC supply voltage with 3-inch ribbon cable terminated with a single in-line
8765F-010	10V DC supply voltage with 3-inch ribbon cable terminated with a single in-line
8765F-015	15V DC supply voltage with 3-inch ribbon cable terminated with a single in-line
8765F-024	24V DC supply voltage with 3-inch ribbon cable terminated with a single in-line
8765F-305	5V DC supply voltage with solder terminals
8765F-310	10V DC supply voltage with solder terminals
8765F-315	15V DC supply voltage with solder terminals
8765F-324	24V DC supply voltage with solder terminals

Accessories (optional)

8765x-108	8-inch (20.3 cm) DC cable extension
8765x-116	16-inch (40.6 cm) DC cable extension

Agilent Technologies' Test and Measurement Support, Services, and Assistance

Agilent Technologies aims to maximize the value you receive, while minimizing your risk and problems. We strive to ensure that you get the test and measurement capabilities you paid for and obtain the support you need. Our extensive support resources and services can help you choose the right Agilent products for your applications and apply them successfully. Every instrument and system we sell has a global warranty. Support is available for at least five years beyond the production life of the product. Two concepts underlie Agilent's overall support policy: "Our Promise" and "Your Advantage."

Our Promise

Our Promise means your Agilent test and measurement equipment will meet its advertised performance and functionality. When you are choosing new equipment, we will help you with product information, including realistic performance specifications and practical recommendations from experienced test engineers. When you use Agilent equipment, we can verify that it works properly, help with product operation, and provide basic measurement assistance for the use of specified capabilities, at no extra cost upon request. Many self-help tools are available.

Your Advantage

Your Advantage means that Agilent offers a wide range of additional expert test and measurement services, which you can purchase according to your unique technical and business needs. Solve problems efficiently and gain a competitive edge by contracting with us for calibration, extra-cost upgrades, out-of-warranty repairs, and onsite education and training, as well as design, system integration, project management, and other professional engineering services. Experienced Agilent engineers and technicians worldwide can help you maximize your productivity, optimize the return on investment of your Agilent instruments and systems, and obtain dependable measurement accuracy for the life of those products.



Agilent Email Updates

www.agilent.com/find/emailupdates

Get the latest information on the products and applications you select.

Agilent T&M Software and Connectivity

Agilent's Test and Measurement software and connectivity products, solutions and developer network allows you to take time out of connecting your instruments to your computer with tools based on PC standards, so you can focus on your tasks, not on your connections. Visit

www.agilent.com/find/connectivity

for more information.

By internet, phone, or fax, get assistance with all your test & measurement needs

Phone or Fax

United States:

(tel) 800 452 4844

Canada:

(tel) 877 894 4414

(fax) 905 282 6495

China:

(tel) 800 810 0189

(fax) 800 820 2816

Europe:

(tel) (31 20) 547 2323

(fax) (31 20) 547 2390

Japan:

(tel) (81) 426 56 7832

(fax) (81) 426 56 7840

Korea:

(tel) (82 2) 2004 5004

(fax) (82 2) 2004 5115

Latin America:

(tel) (305) 269 7500

(fax) (305) 269 7599

Taiwan:

(tel) 0800 047 866

(fax) 0800 286 331

Other Asia Pacific Countries:

(tel) (65) 6375 8100

(fax) (65) 6836 0252

Email: tm_asia@agilent.com

Online Assistance:

www.agilent.com/find/assist

Product specifications and descriptions in this document subject to change without notice.

© Agilent Technologies, Inc. 2002

Printed in USA September 16, 2002

5091-2679E

