

Agilent
83554A/83555A/83556A
mm-wave Source Modules*
Data Sheet

26.5 to 40.0 GHz
33.0 to 50.0 GHz
40.0 to 60.0 GHz

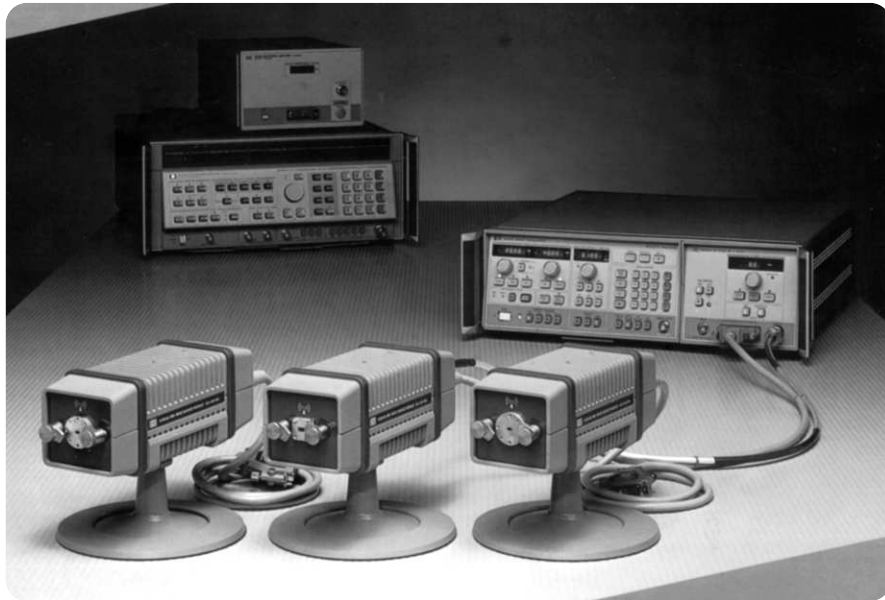

*Precision and power from a
millimeter-wave swept solution*

* For mm-wave source modules from 50 to 110 GHz (Agilent model numbers 83557A and 83558A) please refer to publication number 5958-0398.



Agilent Technologies

The solution to your millimeter-wave signal source needs

The 83550-series millimeter-wave source modules provide millimeter-wave test signals for waveguide bands from 26.5 to 60 GHz when driven by 11 to 20 GHz microwave sources. The 83550-series source modules offer internally-leveled high output power, full waveguide band frequency coverage, and the high frequency accuracy and resolution of the driving microwave source.

There are several ways of configuring a millimeter-wave source to best suit your specific needs. For swept-frequency testing, choose the 8 to 20 GHz 83550A RF plug-in for the 8350B mainframe as the microwave source driver for the source module covering your frequency range. The 83550A offers +20 dBm of internally- leveled output power from 8 to 18.6 GHz and +18 dBm from 18.6 to 20 GHz. This meets the required input power for the source modules (+17 dBm) to give you a one-step solution.

An alternate way to generate swept signals is to use your new or existing microwave source with the 8349B microwave amplifier as the driving microwave source for the source modules. The 8349B microwave amplifier is a compact GaAs FET instrumentation amplifier that delivers +20 dBm of output power from 2 to 18.6 GHz and +18 dBm of output power from 18.6 to 20 GHz.

Thus, when you need a millimeter-wave sweeper, the 8350B sweep oscillator has the 83590-series RF plug-ins driving an 8349B microwave amplifier, or an 83550A plug-in to operate over the frequency range required by the 83550-series millimeter-wave source modules. Many capabilities and features of the 8350B are translated through the source modules to the millimeter-

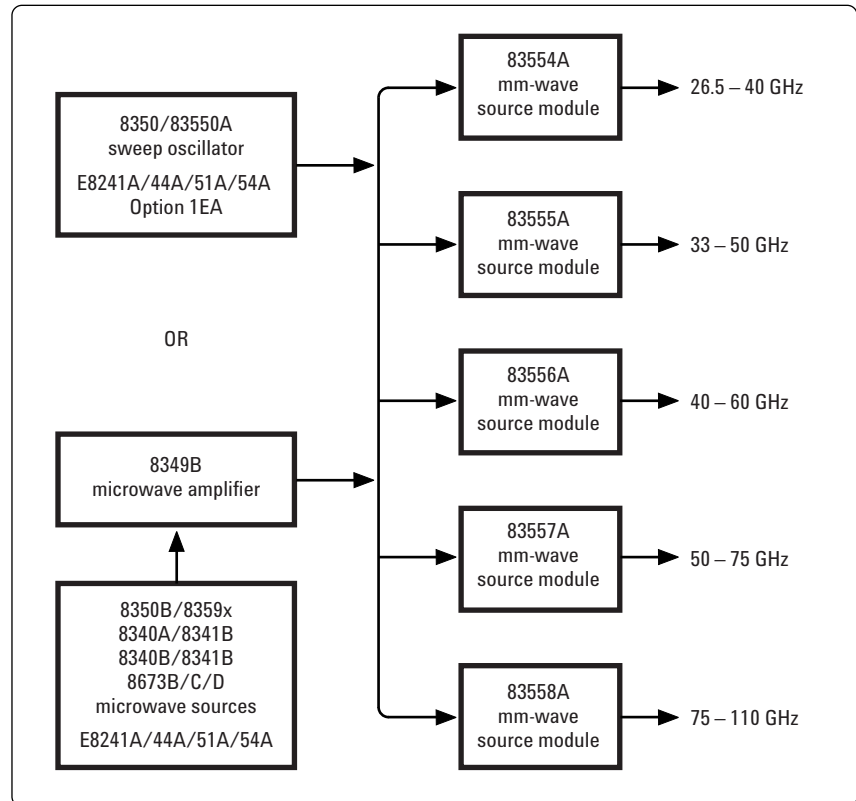

wave bands. These include the continuous analog sweep, alternate sweep, five independent frequency markers, high frequency accuracy, programmable and calibrated output power (83500-series only), internal and external leveling, and complete programmability.

When increased frequency accuracy, frequency stability and high spectral purity are required, the 8340A/8341A or 8340B/8341B synthesized sweepers and the 8349B microwave amplifier are attractive drivers for the source modules. Besides all the sweep oscillator features listed for the 8350B sweeper, an 8340/8341-based millimeter-wave source delivers a highly-accurate and spectrally-pure signal with a frequency resolution of 6 Hz at 26.5 GHz and 9 Hz at 60 GHz. The 8340B/8341B synthesized sweepers additionally offer calibrated output power that can be set from the front panel or over the GPIB bus. Improved external amplitude and pulse modulation capability is provided, as well as external frequency modulation capability. The 8673B/C/D

synthesized signal generators can also drive the 8349B microwave amplifier to offer similar synthesized CW performance. In addition to the synthesized frequency performance, high-performance AM, FM and pulse modulation make these synthesizers ideal for many signal simulation applications.

The small size of the 83550-series source modules mean you can use them even on a crowded benchtop. Additionally, two flexible cables, an RF cable and a source module interface cable are provided with the source modules to connect the microwave source driver to the source module. These cables allow you to place the source module up to 1 meter from the driving source. Now you can bring your source to your test system instead of the other way around.

The 83550-series millimeter-wave source modules deliver excellent performance, versatility and reliability at a reasonable cost. They make simple, high-quality measurements at millimeter-wave frequencies a reality.

High accuracy and resolution

Because the 83550-series source modules use frequency multiplication to generate millimeter-wave frequencies, the millimeter-wave system frequency specifications are directly proportional to those of the microwave source driving the source modules. Frequency accuracy, stability, and resolution specifications are multiplied by a factor of either two or three depending on whether the drive frequency is doubled or tripled. For example, a millimeter-wave source based on the 8341B/8349B will have frequency resolution of 6 Hz in the 26.5 to 40 GHz band, 9 Hz in the 33 to 50 GHz band, and 9 Hz in the 4 to 60 GHz band.

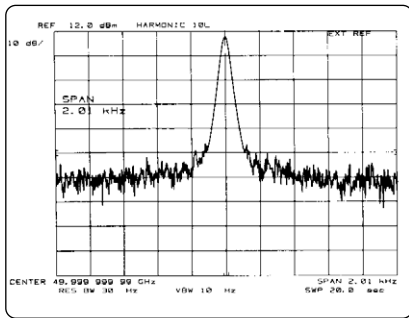

Spectrum analyzer photo of 8340A/8349B/83556A signal at 50 GHz.

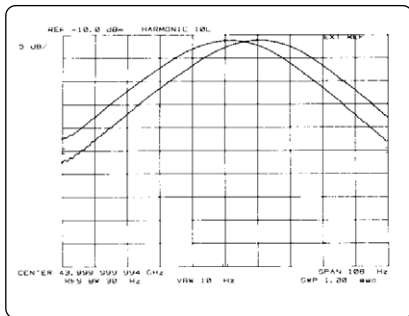

Spectrum analyzer photo of 8341A/8349B/83555A signals at 44 GHz with resolution of 10 Hz.

Spectral purity

The 83550-series source modules offer harmonic and sub-harmonic suppression of >20 dBc in any band. Greater spectral purity (>40 to 50 dBc) can be achieved in certain frequency ranges by using a harmonically clean microwave source such as the 8350B/83550A, 8673B/C/D, 8350B/83592C or 8341B Option 003 to drive the source module. Low harmonics help to increase the validity and range of many millimeter-wave measurements.

When the 8340B/41B or 8673B/C/D synthesizers (combined with the required 8349B amplifier) serve as the driving microwave source for the source modules, their high stability and low phase noise performance are available for a variety of signal simulation applications. For example, the phase noise performance of the 8340B/8349B/83554A is typically -70 dBc in a 1 Hz noise bandwidth at 10 kHz offset from a 35 GHz carrier.

High output power

The 83550-series source modules provide plenty of output power. This high output power can permit the source module to serve as a mixer LO in some applications. High power also expands the available dynamic range in frequency response measurements.

The 83550-series source modules also offer internal leveling. The output power of the source module is displayed on the 83550A, 8340B/8341B, 8673B/C/D or the 8349B power display (depending on your millimeter-wave source configuration) to yield 0.1 dB of digitally-displayed resolution.

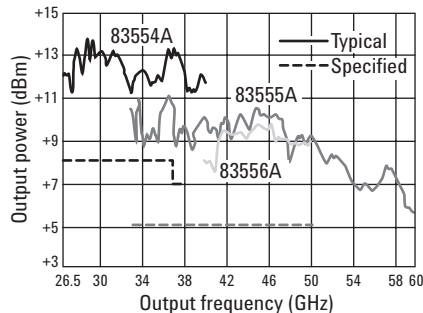

Typical maximum leveled output power available from the 83550-series millimeter-wave source modules.

Operational simplicity

The digital displays on the microwave source drivers indicate the active function values, including sweep limit frequencies, sweep time and output power. This makes your measurements easier, faster and more efficient. Simple front panel operations let you enter a display multiplier, so that the actual output frequency of the source module may be entered and displayed directly on the microwave source driver.

For multiple test setup sequences, each of the nine internal nonvolatile storage registers, standard on the microwave source drivers, can save the entire instrument state for later, rapid recall.

And complete programmability

The complete programmability of all functions of the microwave sources via the GPIB* is directly translated through the 83550-series source modules to provide you with the most powerful millimeter-wave sources in the industry.

More than just IEEE-488, GPIB is an internationally accepted standard, so you can easily integrate the microwave source drivers into existing automatic systems as well as new ones. Mnemonic programming codes simplify software development and reduce programming and debugging time. Finally, GPIB also means that all the documentation is available for you to design, configure, and program your own system with minimum development time.

All at a lower cost

Until now, sources at millimeter-wave frequencies were usually high cost items. Now, the 83550-series source modules change all that by combining performance and quality with a low cost of entry. This is possible because the source modules are backward-compatible with existing Agilent microwave sources. Thus, you can generate a full waveguide band of millimeter-wave frequencies for just the cost of the 8349B and a source module. Also, low cost of ownership is enhanced by the two-year warranty on the microcircuits of the 83550-series source modules and the 8349B microwave amplifier.

*GPIB is Agilent Technologies' hardware, software, documentation, and support for IEEE-488 and IEC-625, worldwide standards for interfacing instruments.

Millimeter-wave swept systems for high-quality measurements

Tracking two-tone sweep

Broadband testing of mixers, receiver front-ends, and frequency translators is greatly simplified with this “two tone” source configuration. Using one source for RF drive and the other for LO, they can be offset in frequency equal to the IF of the device under test. This tracking two-tone sweep significantly reduces measurement time by producing a swept display of the device's frequency response over the full frequency range of millimeter-wave sources based on Agilent's 8350B sweep oscillators.

In addition, you can reduce the effects of LO feedthru at the mixer output by using AC detection of the 8756A or 8757A scalar network analyzers. By modulating the RF input and not modulating the LO input, the desired IF signal will be modulated but the undesired LO feedthru will not. Since the AC detectors only respond to signals modulated by 27.8 kHz, the unmodulated LO feedthru does not cause an inaccuracy in the conversion loss measurement. For further information refer to application note 312-1 (publication number 5952-9316).

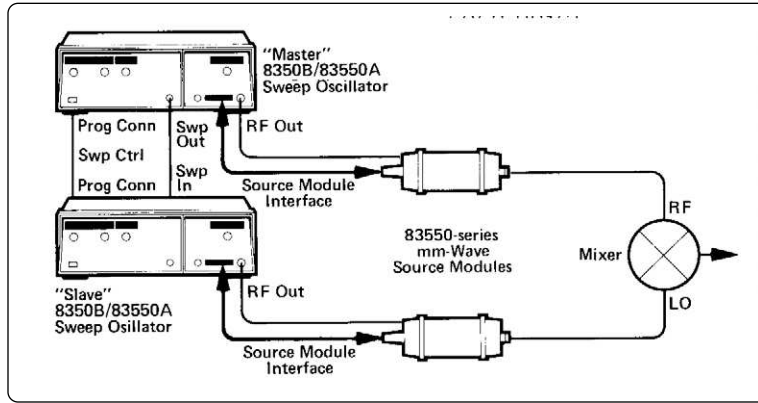

Exceptional modulation capabilities

Radar and ECM threat simulation make high-performance demands on millimeter-wave sources. The 83550-series source modules combined with the 8340/8341 or the 8673B/C/D synthesizers and an 8349B microwave amplifier help meet these demands for broadband frequency coverage and high-performance modulation. For example, you can use their ability to simultaneously pulse and amplitude modulate the RF signal to simulate the effect of an antenna scan on a pulse-modulated signal.

Agilent's 8340B/8341B and 8673B/C/D have internal pulse modulators to provide calibrated, leveled pulse modulation with 80 dB on/off ratio over the full frequency range.

DC coupled AM is available on the 8340/8341 and 8673B/C/D when an external modulation source is used. Since the AM circuitry is DC coupled, it can accurately reproduce complex waveforms that have a DC component, such as the antenna scan waveform. The 8340B/8341B, for example, operates at rates ranging from DC to 100 kHz.

FM may be applied to the 8340B/8341B or 8673B/C/D synthesizer input and the corresponding millimeter-wave frequency output will be modulated with an FM deviation two or three times (depending on the source module used) the modulation input at the same rate. For example, the 8673B/8349B/83556A combination can be frequency-modulated at rates between 100 Hz and 10 MHz with deviations up to 30 MHz.

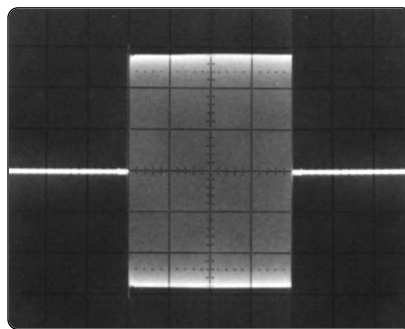

8340A/8349B/83554A pulse performance at 35 GHz. Pulse width = 5 ms.

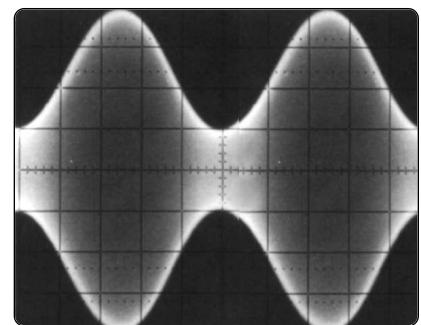

8341A/8349B/83554A AM performance at 30 GHz. AM rate is 17 kHz and depth is 70%.

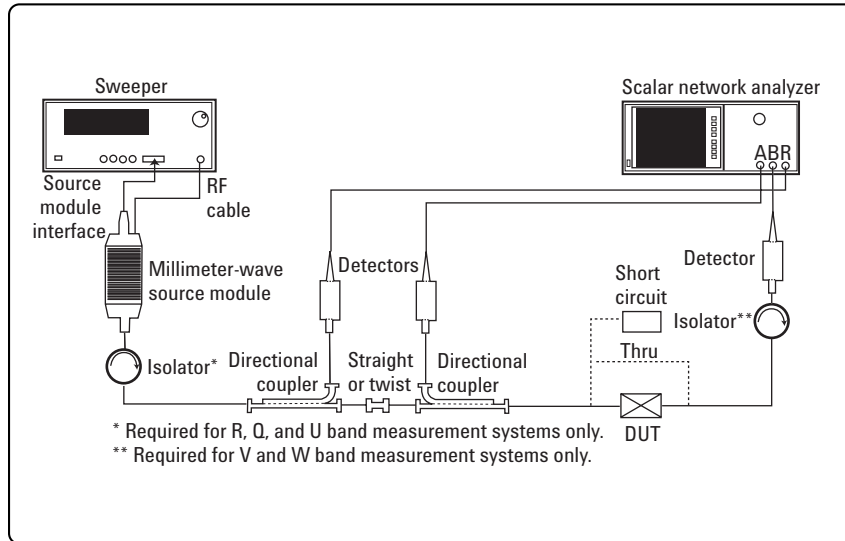

Typical scalar transmission and reflection measurement setup from 33 to 50 GHz.

Scalar network analysis

Scalar measurements to 110 GHz are facilitated by the use of the Agilent 83550 series millimeter-wave source modules. When these modules are driven by an 11 to 20 GHz, > +17 dBm microwave source, such as the Agilent 83623B, 83624B, or any source in conjunction with an Agilent 8349B amplifier, they provide waveguide frequency coverage to 110 GHz. These efficient frequency multipliers offer internally leveled, high output power, and the high frequency accuracy and resolution of the driving microwave source.

83554A specifications

Specifications describe the instruments warranted performance over the temperature range 0 °C to 55 °C (except where noted). Supplemental characteristics are intended to provide information useful in applying the instrument by giving typical but non-warranted performance parameters. These are denoted as typical, nominal or approximately.

Table 1.

	8350B/83550A	8350B/ 83590 series/8349B	8340A/8349B, 8341A/8349B
Frequency characteristics			
Range:	26.5–40.0 GHz	26.5–40.0 GHz	26.5–40.0 GHz
Accuracy (25 °C ±5 °C)			
CW mode ² :	±40 MHz	±20 MHz	Same as time base.
Time base ³ :	—	—	Internal 10 MHz time base Aging rate: less than 1×10^{-9} /day and 2×10^{-7} /year after 30-day warm-up. Temperature effect: $<1 \times 10^{-10}$ /°C Line voltage effect: $<1 \times 10^{-11}$ /±10%
All sweep modes (for sweep time >100 msec):	±100 MHz	±60 MHz	$\Delta F \leq n \times 10$ MHz: ±1% of ΔF ±time base accuracy. $n \times 10$ MHz $< \Delta F$ < 600 MHz: ±2% of ΔF . $\Delta F \geq 600$ MHz: ±1% of ΔF or ±100 MHz whichever is less. (n=harmonic band (1–4) of the 8340/41)
CW resolution:	52 kHz	52 kHz	6 Hz
Stability			
With temperature: Typically	±2 MHz/°C	±1.2 MHz/°C	—
With 10% line voltage change	±300 kHz	±300 kHz	—
With time (in a 10-minute period) ⁴ :	±2 MHz	±600 kHz	Same as time base.
Residual FM, peak (20 Hz–15 kHz bandwidth, CW mode):	<50 kHz	<18 kHz	—
Output characteristics			
Maximum leveled power (25 °C ±5 °C):	+8 dBm, 26.5–37.2 GHz +7 dBm, 37.2–40.0 GHz	+8 dBm, 26.5–37.2 GHz +7 dBm, 37.2–40.0 GHz	+8 dBm, 26.5–37.2 GHz +7 dBm, 37.2–40.0 GHz
Minimum settable power:	–5 dBm	–5 dBm	–5 dBm
Power level accuracy ⁵ (25 °C ±5 °C)			
Internally leveled:	±2.00 dB	±2.00 dB	±2.00 dB
Power flatness (at maximum leveled power)			
Internally leveled:	±1.50 dB	±1.50 dB ⁸	±1.50 dB ⁸
Source output SWR			
Internally leveled:	<2.0	<2.0	<2.0
Unleveled: Typically	<3.0	<3.0	<3.0
Spurious signals ⁶			
26.5–26.7 GHz	>25 dBc	>25 dBc	>25 dBc
26.7–40.0 GHz	>50 dBc	>20 dBc (>45 dBc for 83592C)	>20 dBc
Modulation characteristics			
External FM			
Maximum deviations	Crossover coupled: ±150 MHz (DC–100 Hz) ±27 MHz (100 Hz–6 MHz) Direct coupled: ±27 MHz (DC–6 MHz)	Crossover coupled: ±150 MHz (DC–100 Hz) ±14 MHz (100 Hz–1 MHz) ±10 MHz (1 MHz–2 MHz) ±2 MHz (2 MHz–10 MHz) Direct coupled: ±24 MHz (DC–100 MHz) ±14 MHz (100 Hz–1 MHz) ±10 MHz (1 MHz–2 MHz) ±2 MHz (2 MHz–10 MHz)	—
Sensitivity			
FM mode: Typically	–40 MHz/V	–40 MHz/V	—
Phase-lock mode: Typically	–12 MHz/V	–12 MHz/V	—
External AM			
Bandwidth: Typically	DC–100 kHz	DC–100 kHz	DC–30 kHz
Sensitivity: Typically	1 dB/V	1 dB/V	100%/V
External pulse modulation			
Rise/fall time: Typically	25 ns	1 μs	50 ns
Minimum RF pulse width: Typically			
System leveled:	1 μs	1 μs ⁹	—
System unleveled:	100 ns	100 ns ⁹	100 ns
On/off ratio: Typically	>60 dB	>80 dB	>80 dB
Pulse repetition frequency: (Leveled)	10 Hz–500 kHz	100 Hz–500 kHz ⁹	—
(Unleveled)	DC–5 MHz	100 Hz–5 MHz	100 Hz–5 MHz
8757D AC detection mode compatibility	Yes	Yes	No

Table 1. continued

8340B/8349B, 8341B/8349B	8673B/C/D/8349B1
26.5–40.0 GHz	26.5–40.0 GHz (8673B/D) 26.5–37.2 GHz (8673C)
Same as time base. Internal 10 MHz time base. Aging rate: less than 1×10^{-9} /day and 2×10^{-7} /year after 30-day warm-up. Temperature effect: $<1 \times 10^{-10}/^{\circ}\text{C}$ Line voltage effect: $<1 \times 10^{-11}/\pm 10\%$ $\Delta F \leq n \times 10 \text{ MHz}$: $\pm 1\%$ of ΔF \pm time base accuracy. $n \times 10 \text{ MHz} < \Delta F < 600 \text{ MHz}$: $\pm 2\%$ of ΔF . $\Delta F \geq 600 \text{ MHz}$: $\pm 1\%$ of ΔF or $\pm 100 \text{ MHz}$ whichever is less. (n=harmonic band (1–4) of the 8340/41)	Same as time base. Internal 10 MHz time base. Aging rate: less than 5×10^{-10} /day and 2×10^{-7} /year after a 24-hour warmup. Temperature effect: $<1 \times 10^{-10}/^{\circ}\text{C}$ Line voltage effect: $<5 \times 10^{-10}/+5\%$ to -10% Same as time base.
6 Hz	6 Hz (8 kHz for 8673B/D from 37.2–40 GHz)
—	—
—	—
Same as time base.	Same as time base.
—	—
+8 dBm, 26.5–37.2 GHz +7 dBm, 37.2–40.0 GHz –5 dBm	+8 dBm, 26.5–37.2 GHz +7 dBm, 37.2–40.0 GHz –5 dBm
$\pm 2.00 \text{ dB}$	$\pm 2.00 \text{ dB}^7$
$\pm 1.50 \text{ dB}^8$	$\pm 1.50 \text{ dB}^8$
<2.0 <3.0	<2.0 <3.0
$>25 \text{ dBc}$ $>20 \text{ dBc}$ ($>40 \text{ dBc}$ for 8341B Option 003)	$>25 \text{ dBc}$ $>20 \text{ dBc}$ ($>50 \text{ dBc}$ for 8673C/D)
$\pm 20 \text{ MHz}$ or $\pm 20 \times f_{\text{mod}}$, 26.5–27 GHz $\pm 30 \times f_{\text{mod}}$, 27–40 GHz Whichever is less (50 kHz–10 MHz)	$\pm 20 \text{ MHz}$ or $\pm 30 \times f_{\text{mod}}$, 26.5–37.2 GHz $\pm 40 \times f_{\text{mod}}$, 37.2–40.0 GHz Whichever is less (100 Hz–10 MHz with 0.06 or 0.2 MHz/V range, 1 kHz–10 MHz with 0.6, 2, 6 or 20 MHz/V range.)
2 MHz/V or 20 MHz/V	0.06, 0.2, 0.6, 2, 6 or 20 MHz/V
—	—
DC–100 kHz 100%/V	DC–80 kHz 30%/V and 100%/V
50 ns	50 ns
1 μs 100 ns >80 dB 100 Hz–50 kHz 100 Hz–5 MHz	5 μs^{10} 50 ns >80 dB 50 Hz–100 kHz 50 Hz–500 kHz
Yes	Yes

8340A/8340B/8341B/8349B/83554A single-sideband phase noise (dBc/1 Hz noise BW, CW mode, all power levels)

Frequency range (GHz)	Offset from carrier				
	30 Hz	100 Hz	1 kHz	10 kHz	100 kHz
26.5 to 27.0	–52	–58	–66	–74	–95
27.0 to 40.0	–48	–54	–62	–70	–91

8341A/8349B/83554A single-sideband phase noise (dBc/1 Hz noise BW, CW mode, all power levels)

Frequency range (GHz)	Offset from carrier				
	30 Hz	100 Hz	1 kHz	10 kHz	100 kHz
26.5 to 27.0	—	–55	–63	–71	–95
27.0 to 40.0	—	–51	–59	–67	–91

8673B/C/D/8349B/83554A single-sideband phase noise (dBc/1 Hz noise BW, CW mode, all power levels)

Frequency range (GHz)	Offset from carrier				
	10 Hz	100 Hz	1 kHz	10 kHz	100 kHz
26.5 to 27.0	–42	–54	–62	–70	–94
27.0 to 40.0	–40	–52	–60	–66	–92

General specifications

Input frequencies: 13.25 to 20.00 GHz

Minimum input power level into 83554A RF input cable: +17 dBm (50 mW)

Maximum input power level into 83554A RF input cable: +27 dBm (0.5W)

Waveguide output connector: EIA size WR 28 waveguide. Mates with JAN UG-599 flange.

Weight: Net, 1.7 kg (4 lb.)

Dimensions:

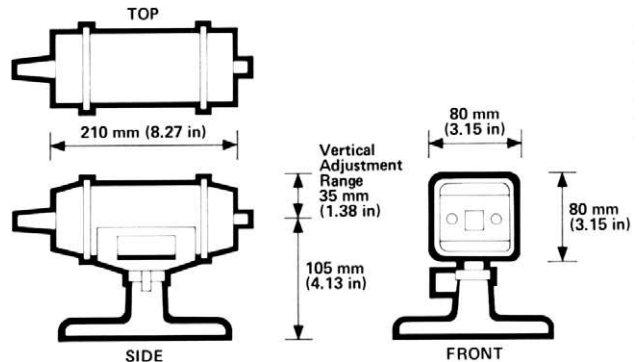

Furnished with each 83554A: Operating and service manual, (part number 83554-90001), procedure and parts for 8340 series/83590 series 0.5 V/GHz modification (part number 83554-90016), RF cable (part number 5061-5359), synthesizer interface cable (part number 5061-5391), module base assembly (part number 83556-60010).

- To achieve specified performance, the unit may need modifications. Refer to pages 14 and 15 for details.
- Specifications referenced are source driver specific and do not include the doubling effect of the source module.
- The overall accuracy of the internal time base is a function of time base calibration \pm aging rate \pm temperature effects \pm line effects.
- After one hour warm-up at selected CW frequency.
- Specified with respect to power display. Includes power level flatness.
- Expressed in dB relative to carrier (dBc).
- When remotely programmed and when power is referenced to the front panel display, add $\pm 0.75 \text{ dB}$.
- Must have 0.5 V/GHz modification.
- Pulse modulation characteristics of Agilent's 83592A/B/C or 83595A based source configuration only.
- Typical pulse level accuracy of $\pm 1.5 \text{ dB}$ relative to CW.

83555A specifications

Specifications describe the instruments warranted performance over the temperature range 0°C to 55°C (except where noted). *Supplemental characteristics* are intended to provide information useful in applying the instrument by giving typical but non-warranted performance parameters. These are denoted as typical, nominal or approximately.

Table 2.

	8350B/83550A	8350B/ 83590 series/8349B	8340A/8349B, 8341A/8349B
Frequency characteristics			
Range:	33.0–50.0 GHz	33.0–50.0 GHz	33.0–50.0 GHz
Accuracy (25°C±5°C)			
CW mode ² :	±60 MHz	±30 MHz	Same as time base.
Time base ³ :	—	—	Internal 10 MHz time base Aging rate: less than 1 x 10 ⁻⁹ /day and 2 x 10 ⁻⁷ /year after 30-day warm-up. Temperature effect: <1 x 10 ⁻¹⁰ /°C Line voltage effect: <1 x 10 ⁻¹¹ /±10%
All sweep modes (for sweep time >100 msec):	±150 MHz	±90 MHz	ΔF ≤ n x 15 MHz: ±1% of ΔF ±time base accuracy. n x 15 MHz <ΔF <900 MHz: ±2% of ΔF. ΔF ≥900 MHz: ±1% of ΔF or ±150 MHz whichever is less. (n=harmonic band (1–4) of the 8340/41)
CW resolution:	78 kHz	78 kHz	6 Hz, 33.0–40.5 GHz 9 Hz, 40.5–50.0 GHz
Stability			
With temperature: Typically	±3 MHz/°C	±1.8 MHz/°C	—
With 10% line voltage change	±450 kHz	±450 kHz	—
With time (in a 10-minute period) ⁴ :	±3 MHz	<±900 kHz	Same as time base.
Residual FM, peak (20 Hz–15 kHz bandwidth, CW mode):	<75 kHz	<27 kHz	—
Output characteristics			
Maximum leveled power (25°C±5°C):	+3 dBm	+3 dBm	+3 dBm
Minimum settable power:	-5 dBm	-5 dBm	-5 dBm
Power level accuracy ⁵ (25°C±5°C)			
Internally leveled:	±2.00 dB	±2.00 dB	±2.00 dB
Power flatness (at maximum leveled power)			
Internally leveled:	±1.50 dB	±1.50 dB ⁸	±1.50 dB ⁸
Source output SWR			
Internally leveled:	<2.0	<2.0	<2.0
Unleveled: Typically	<3.0	<3.0	<3.0
Spurious signals ⁶			
33.0–37.5 GHz	>20 dBc	>20 dBc	>20 dBc
37.5–49.5 GHz	>50 dBc	>20 dBc (>45 dBc for 83592C)	>20 dBc
49.5–50.0 GHz	>20 dBc	>20 dBc	>20 dBc
Modulation characteristics			
External FM			
Maximum deviations	Crossover coupled: ±225 MHz (DC–100 Hz) ±40.5 MHz (100 Hz–6 MHz) Direct coupled: ±40.5 MHz (DC–6 MHz)	Crossover coupled: ±225 MHz (DC–100 Hz) ±21 MHz (100 Hz–1 MHz) ±15 MHz (1 MHz–2 MHz) ±3 MHz (2 MHz–10 MHz) Direct coupled: ±36 MHz (DC–100 MHz) ±21 MHz (100 Hz–1 MHz) ±15 MHz (1 MHz–2 MHz) ±3 MHz (2 MHz–10 MHz)	—
Sensitivity			
FM mode: Typically	-60 MHz/V	-60 MHz/V	—
Phase-lock mode: Typically	-18 MHz/V	-18 MHz/V	—
External AM			
Bandwidth: Typically	DC–100 kHz	DC–100 kHz	DC–30 kHz
Sensitivity: Typically	1 dB/V	1 dB/V	100%/V
External pulse modulation			
Rise/fall time: Typically	25 ns	1 μs	50 ns
Minimum RF pulse width: Typically			
System leveled:	1 μs	1 μs ⁹	—
System unleveled:	100 ns	100 ns ⁹	100 ns
On/off ratio: Typically	>60 dB	>80 dB	>80 dB
Pulse repetition frequency: (Leveled)	10 Hz–500 kHz	100 Hz–500 kHz ⁹	—
(Unleveled)	DC–5 MHz	100 Hz–5 MHz	100 Hz–5 MHz
8757D AC detection mode compatibility	Yes	Yes	No

Table 2. continued

8340B/8349B, 8341B/8349B	8673B/C/D/8349B1
33.0–50.0 GHz	33.0–50.0 GHz
Same as time base. Internal 10 MHz time base Aging rate: less than 1×10^{-9} /day and 2×10^{-7} /year after 30-day warm-up. Temperature effect: $<1 \times 10^{-10}/^{\circ}\text{C}$ Line voltage effect: $<1 \times 10^{-11}/\pm 10\%$ $\Delta F \leq n \times 10 \text{ MHz}$: $\pm 1\%$ of $\Delta F \pm$ time base accuracy. $n \times 10 \text{ MHz} < \Delta F$ $<600 \text{ MHz}$: $\pm 2\%$ of ΔF . $\Delta F \geq 600 \text{ MHz}$: $\pm 1\%$ of ΔF or $\pm 100 \text{ MHz}$ whichever is less. (n=harmonic band (1–4) of the 8340/41)	Same as time base. Internal 10 MHz time base Aging rate: less than 5×10^{-10} /day and 2×10^{-7} /year after a 24-hour warmup. Temperature effect: $<1 \times 10^{-10}/^{\circ}\text{C}$ Line voltage effect: $<5 \times 10^{-10}/+5\%$ to -10% Same as time base.
6 Hz, 33.0–40.5 GHz 9 Hz, 40.5–50.0 GHz	6 Hz (9 kHz for 8673 B/D from 36.9–50 GHz)
—	—
—	—
Same as time base.	Same as time base.
—	—
+3 dBm –5 dBm	+3 dBm –5 dBm
$\pm 2.00 \text{ dB}$	$\pm 2.00 \text{ dB}^7$
$\pm 1.50 \text{ dB}^8$	$\pm 1.50 \text{ dB}^8$
<2.0 <3.0	<2.0 <3.0
$>20 \text{ dBc}$ $>20 \text{ dBc}$ ($>40 \text{ dBc}$ for 8341B Option 003) $>20 \text{ dBc}$	$>20 \text{ dBc}$ $>20 \text{ dBc}$ ($>50 \text{ dBc}$ for 8673 C/D) $>20 \text{ dBc}$
$\pm 30 \text{ MHz}$ or $\pm 30 \times f_{\text{mod}}$, 26.5–27 GHz $\pm 45 \times f_{\text{mod}}$, 27–40 GHz Whichever is less (50 kHz–10 MHz)	$\pm 30 \text{ MHz}$ or $\pm 45 \times f_{\text{mod}}$, 33.0–36.9 GHz $\pm 40 \times f_{\text{mod}}$, 36.9–50.0 GHz Whichever is less (100 Hz–10 MHz with 0.09 or 0.3 MHz/V range, 1 kHz–10 MHz with 0.9, 3, 9 or 30 MHz/V range.)
3 MHz/V or 30 MHz/V	0.09, 0.3, 0.9, 3, 9 or 30 MHz/V
—	—
DC–100 kHz 100%/V	DC–80 kHz 30%/V and 100%/V
50 ns	50 ns
1 μs 100 ns $>80 \text{ dB}$ 100 Hz–50 kHz 100 Hz–5 MHz	5 μs^{10} 50 ns $>80 \text{ dB}$ 50 Hz–100 kHz 50 Hz–500 kHz
Yes	Yes

8340A/8340B/8341B/8349B/83555A single-sideband phase noise (dBc/1 Hz noise BW, CW mode, all power levels)

Frequency range (GHz)	Offset from carrier				
	30 Hz	100 Hz	1 kHz	10 kHz	100 kHz
33.0 to 40.5	–48	–54	–62	–70	–91
40.5 to 50.0	–44	–50	–58	–66	–87

8341A/8349B/83555A single-sideband phase noise (dBc/1 Hz noise BW, CW mode, all power levels)

Frequency range (GHz)	Offset from carrier				
	30 Hz	100 Hz	1 kHz	10 kHz	100 kHz
33.0 to 40.5	—	–55	–59	–67	–91
27.0 to 50.0	—	–47	–55	–63	–87

8673B/C/D/8349B/83555A single-sideband phase noise (dBc/1 Hz noise BW, CW mode, all power levels)

Frequency range (GHz)	Offset from carrier				
	10 Hz	100 Hz	1 kHz	10 kHz	100 kHz
33.0 to 36.9	–42	–54	–62	–70	–94
36.9 to 50.0	–38	–50	–58	–66	–90

General specifications

Input frequencies: 11.000 to 16.667 GHz

Minimum input power level into 83555A RF input cable: +17 dBm (50 mW)

Maximum input power level into 83555A RF input cable: +27 dBm (0.5W)

Waveguide output connector: EIA size WR 28 waveguide. Mates with JAN UG-383 flange.

Weight: Net, 1.7 kg (4 lb.)

Dimensions:

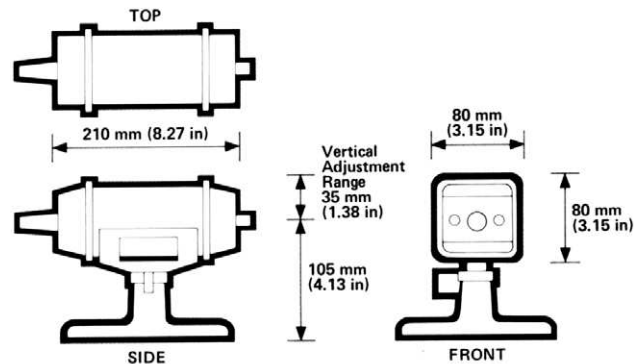

Furnished with each 83555A: Operating and service manual, (part number 83555-90019), procedure and parts for 8340 series/83590 series 0.5 V/GHz modification (part number 83554-90016), RF cable (part number 5061-5359), synthesizer interface cable (part number 5061-5391), module base assembly (part number 83556-60010).

- To achieve specified performance, the unit may need modifications. Refer to pages 14 and 15 for details.
- Specifications referenced are source driver specific and do not include the doubling effect of the source module.
- The overall accuracy of the internal time base is a function of time base calibration \pm aging rate \pm temperature effects \pm line effects.
- After one hour warm-up at selected CW frequency.
- Specified with respect to power display. Includes power level flatness.
- Expressed in dB relative to carrier (dBc).
- When remotely programmed and when power is referenced to the front panel display, add $\pm 0.75 \text{ dB}$.
- Must have 0.5 V/GHz modification.
- Pulse modulation characteristics of Agilent's 83592A/B/C or 83595A based source configuration only.
- Typical pulse level accuracy of $\pm 1.5 \text{ dB}$ relative to CW.

83556A specifications

Specifications describe the instruments warranted performance over the temperature range 0°C to 55°C (except where noted). *Supplemental characteristics* are intended to provide information useful in applying the instrument by giving typical but non-warranted performance parameters. These are denoted as typical, nominal or approximately.

Table 3.

	8350B/83550A	8350B/ 83590 series/8349B	8340A/8349B, 8341A/8349B
Frequency characteristics			
Range:	40.0–60.0 GHz	40.0–60.0 GHz	40.0–60.0 GHz
Accuracy (25°C±5°C)			
CW mode ² :	±60 MHz	±30 MHz	Same as time base.
Time base ³ :	—	—	Internal 10 MHz time base Aging rate: less than 1 x 10 ⁻⁹ /day and 2 x 10 ⁻⁷ /year after 30-day warm-up. Temperature effect: <1 x 10 ⁻¹⁰ /°C Line voltage effect: <1 x 10 ⁻¹¹ /±10%
All sweep modes (for sweep time >100 msec):	±150 MHz	±90 MHz	ΔF ≤ n x 15 MHz: ±1% of ΔF ±time base accuracy. n x 15 MHz <ΔF <900 MHz: ±2% of ΔF. ΔF ≥900 MHz: ±1% of ΔF or ±100 MHz whichever is less. (n=harmonic band (1–4) of the 8340/41)
CW resolution:	78 kHz	78 kHz	6 Hz, 40.0–40.5 GHz 9 Hz, 40.5–60.0 GHz
Stability			
With temperature: Typically	±3 MHz/°C	±1.8 MHz/°C	—
With 10% line voltage change	±450 kHz	±450 kHz	—
With time (in a 10-minute period) ⁴ :	±3 MHz	<±900 kHz	Same as time base.
Residual FM, peak (20 Hz–15 kHz bandwidth, CW mode):	<75 kHz	<27 kHz	—
Output characteristics			
Maximum leveled power (25°C±5°C):	+3 dBm	+3 dBm	+3 dBm
Minimum settable power:	-5 dBm	-5 dBm	-5 dBm
Power level accuracy ⁵ (25°C±5°C)			
Internally leveled:	±2.25 dB	±2.25 dB	±2.25 dB
Power flatness (at maximum leveled power)			
Internally leveled:	±1.75 dB	±1.75 dB ⁸	±1.75 dB ⁸
Source output SWR			
Internally leveled:	<2.0	<2.0	<2.0
Unleveled: Typically	<3.0	<3.0	<3.0
Spurious signals ⁶			
40.0–45.0 GHz	>20 dBc	>20 dBc	>20 dBc
45.0–60.0 GHz	>50 dBc	>20 dBc (>45 dBc for 83592C)	>20 dBc
Modulation characteristics			
External FM			
Maximum deviations	Crossover coupled: ±225 MHz (DC–100 Hz) ±40.5 MHz (100 Hz–6 MHz) Direct coupled: ±40.5 MHz (DC–6 MHz)	Crossover coupled: ±225 MHz (DC–100 Hz) ±21 MHz (100 Hz–1 MHz) ±15 MHz (1 MHz–2 MHz) ±3 MHz (2 MHz–10 MHz) Direct coupled: ±36 MHz (DC–100 MHz) ±21 MHz (100 Hz–1 MHz) ±15 MHz (1 MHz–2 MHz) ±3 MHz (2 MHz–10 MHz)	—
Sensitivity			
FM mode: Typically	-60 MHz/V	-60 MHz/V	—
Phase-lock mode: Typically	-18 MHz/V	-18 MHz/V	—
External AM			
Bandwidth: Typically	DC–100 kHz	DC–100 kHz	DC–30 kHz
Sensitivity: Typically	1 dB/V	1 dB/V	100%/V
External pulse modulation			
Rise/fall time: Typically	25 ns	1 μs	50 ns
Minimum RF pulse width: Typically			
System leveled:	1 μs	1 μs ⁹	—
System unleveled:	100 ns	100 ns ⁹	100 ns
On/off ratio: Typically	>60 dB	>80 dB	>80 dB
Pulse repetition frequency: (Leveled)	10 Hz–500 kHz	100 Hz–500 kHz ⁹	—
(Unleveled)	DC–5 MHz	100 Hz–5 MHz	100 Hz–5 MHz
8757D AC detection mode compatibility	Yes	Yes	No

Table 3. continued

8340B/8349B, 8341B/8349B	8673B/C/D/8349B1
40.0–60.0 GHz	40.0–60.0 GHz (8673B/D) 40.0–55.8 GHz (8673C)
Same as time base. Internal 10 MHz time base Aging rate: less than 1×10^{-9} /day and 2×10^{-7} /year after 30-day warm-up. Temperature effect: $<1 \times 10^{-10}/^{\circ}\text{C}$ Line voltage effect: $<1 \times 10^{-11}/\pm 10\%$ $\Delta F \leq n \times 15 \text{ MHz}$: $\pm 1\%$ of ΔF \pm time base accuracy. $n \times 15 \text{ MHz} < \Delta F$ $<900 \text{ MHz}$: $\pm 2\%$ of ΔF . $\Delta F \geq 900 \text{ MHz}$: $\pm 1\%$ of ΔF or $\pm 100 \text{ MHz}$ whichever is less. (n =harmonic band (1–4) of the 8340/41)	Same as time base. Internal 10 MHz time base Aging rate: less than 5×10^{-10} /day after a 24-hour warmup. Temperature effect: $<1 \times 10^{-10}/^{\circ}\text{C}$ Line voltage effect: $<5 \times 10^{-10}/+5\%$ to -10% Same as time base.
6 Hz, 40.0–40.5 GHz 9 Hz, 40.5–60.0 GHz	9 Hz (12 kHz for 8673 B/D from 55.8–60.0 GHz)
—	—
—	—
Same as time base.	Same as time base.
—	—
+3 dBm –5 dBm	+3 dBm –5 dBm
$\pm 2.25 \text{ dB}$	$\pm 2.25 \text{ dB}^7$
$\pm 1.75 \text{ dB}^8$	$\pm 1.75 \text{ dB}^8$
<2.0 <3.0	<2.0 <3.0
$>20 \text{ dBc}$ $>20 \text{ dBc}$ ($>40 \text{ dBc}$ for 8341B Option 003)	$>20 \text{ dBc}$ $>20 \text{ dBc}$ ($>50 \text{ dBc}$ for 8673C/D)
$\pm 30 \text{ MHz}$ or $\pm 30 \times f_{\text{mod}}$, 40.0–40.5 GHz $\pm 45 \times f_{\text{mod}}$, 40.5–60.0 GHz Whichever is less (50 kHz–10 MHz)	$\pm 30 \text{ MHz}$ or $\pm 45 \times f_{\text{mod}}$, 40.0–55.8 GHz $\pm 60 \times f_{\text{mod}}$, 55.8–60.0 GHz Whichever is less (100 Hz–10 MHz with 0.09 or 0.3 MHz/V range, 1 kHz–10 MHz with 0.9, 3, 9 or 30 MHz/V range.)
2 MHz/V or 20 MHz/V	0.09, 0.3, 0.9, 3, 9 or 30 MHz/V
—	—
DC–100 kHz 100%/V	DC–80 kHz 30%/V and 100%/V
50 ns	50 ns
1 μs 100 ns >80 dB 100 Hz–50 kHz 100 Hz–5 MHz	5 μs^{10} 50 ns >80 dB 50 Hz–100 kHz 50 Hz–500 kHz
Yes	Yes

8340A/8340B/8341B/8349B/83556A single-sideband phase noise
(dBc/1 Hz noise BW, CW mode, all power levels)

Frequency range (GHz)	Offset from carrier				
	30 Hz	100 Hz	1 kHz	10 kHz	100 kHz
40.0 to 40.5	–48	–54	–62	–70	–91
40.5 to 60.0	–44	–50	–58	–66	–87

8341A/8349B/83556A single-sideband phase noise
(dBc/1 Hz noise BW, CW mode, all power levels)

Frequency range (GHz)	Offset from carrier				
	30 Hz	100 Hz	1 kHz	10 kHz	100 kHz
40.0 to 40.5	—	–51	–59	–67	–91
40.5 to 60.0	—	–47	–55	–63	–87

8673B/C/D/8349B/83556A single-sideband phase noise
(dBc/1 Hz noise BW, CW mode, all power levels)

Frequency range (GHz)	Offset from carrier				
	10 Hz	100 Hz	1 kHz	10 kHz	100 kHz
40.0 to 55.8	–38	–50	–58	–66	–90
55.8 to 60.0	–36	–48	–56	–64	–88

General specifications

Input frequencies: 13.333 to 20.000 GHz

Minimum input power level into 83556A RF input cable: +17 dBm (50 mW)

Maximum input power level into 83556A RF input cable: +27 dBm (0.5W)

Waveguide output connector: EIA size WR 19 waveguide. Mates with JAN UG-383 flange.

Weight: Net, 1.7 kg (4 lb.)

Dimensions:

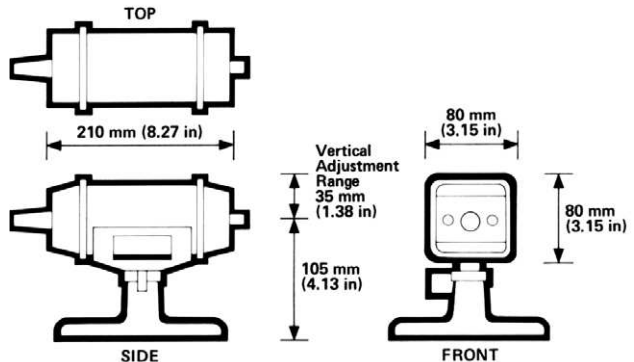

Furnished with each 83556A: Operating and service manual, (part number 83556-90019), procedure and parts for 8340 series/83590 series 0.5 V/GHz modification (part number 83554-90016), RF cable (part number 5061-5359), synthesizer interface cable (part number 5061-5391), module base assembly (part number 83556-60010).

- To achieve specified performance, the unit may need modifications. Refer to pages 14 and 15 for details.
- Specifications referenced are source driver specific and do not include the doubling effect of the source module.
- The overall accuracy of the internal time base is a function of time base calibration \pm aging rate \pm temperature effects \pm line effects.
- After one hour warm-up at selected CW frequency.
- Specified with respect to power display. Includes power level flatness.
- Expressed in dB relative to carrier (dBc).
- When remotely programmed and when power is referenced to the front panel display, add $\pm 0.75 \text{ dB}$.
- Must have 0.5 V/GHz modification.
- Pulse modulation characteristics of Agilent's 83592A/B/C or 83595A based source configuration only.
- Typical pulse level accuracy of $\pm 1.5 \text{ dB}$ relative to CW.

Additional family equipment

83557A/83558A 50 to 75 GHz/75 to 110 GHz mm-wave source modules

Utilize the Agilent Technologies 83557A/83558A mm-wave source modules to obtain high power, high quality signals covering the full waveguide bands of 50 to 75 GHz (V Band) and 75 to 110 GHz (W Band). These efficient frequency multipliers translate a 50 mW (+17 dBm) microwave signal (12.5 to 18.75 GHz) to a mmwave signal at a very low cost compared to other alternatives. With their reliable, solid state design, these modules are small and lightweight and can be operated remotely from the driving source to better accommodate your measurement setup needs. For further information (specifications and ordering info.) please refer to the 83557A/83558A mm-Wave source Module publication (publication number 5958-0398).

Complementary equipment

Specifications describe the instruments warranted performance over the temperature range 0° to 55° C (except where noted). *Supplemental characteristics* are intended to provide information useful in applying the instrument by giving typical but non-warranted performance parameters. These are denoted as typical, nominal or approximately.

8349B microwave amplifier

Millimeter-wave signal sources can be easily configured using new or existing microwave sources with the 8349B microwave amplifier (option 002 recommended) as a driver for the 83550 series millimeter-wave source modules. The 8349B 2 to 20 GHz

microwave amplifier provides the +17 dBm of output power required by the 83550-series millimeter-wave source modules as well as the DC bias and other control lines the source modules need for proper operation.

With 2 to 20 GHz frequency coverage and up to +20 dBm of output power, the 8349B is also an excellent general-purpose instrumentation amplifier. For details, refer to the 8349B data sheet (publication number 5954-1519).

83550A RF plug-in

The 83550A is an 8 to 20 GHz RF plug-in for the 8350B sweep oscillator mainframe with +18 dBm of internally-leveled output power across its full frequency range. This high power makes it suitable for a wide range of microwave applications, and also enables it to directly drive the 83550-series millimeter-wave source modules. The 83550A also supplies the DC bias and other control lines the source modules need for proper operation. For details, refer to the 83550A data sheet (publication number 5954-1521).

11720A pulse modulator

The 11720A is a high-performance pulse modulator covering the range of 2 to 18 GHz. Driven by a pulse generator, this modulator can modulate the microwave output from microwave sources (including a 8349B microwave amplifier) to produce unleveled RF pulses with 10 nsec rise and fall times and >80 dB on/off ratio. This combination driving the 83550-series millimeter-wave source modules can deliver high-quality pulse performance to 60 GHz. For details, refer to the 11720A data sheet (publication number 5952-8240).

E8241A/44A/51A/54A PSG series (250 KHz to 40 GHz) performance signal generator

The PSG series comes standard with a millimeter head interface that is compatible with Agilent's 83550 series millimeter heads for frequency coverage up to 110 GHz. All four models of the PSG series with Option 1EA have enough power to drive millimeter heads directly which eliminates the need for an external amplifier.

The PSG series provides the extra power required eliminating the need for external amplifiers. The PSG series also provides the broad frequency coverage available with a microwave source. This reduces your need for an additional RF source to test at low frequencies. Both of these features simplify test setups and reduce costs. For further details refer to the following Publications:

E8241A/44A/51A/54A
Product Overview
(publication number 5988-2567EN),
E8241A/44A/51A/54A
Configuration Guide
(publication number 5988-2413EN),
E8241A/44A/51A/54A Data Sheet
(publication number 5988-2412EN) and
E8241A/44A/51A/54A Product Note
(publication number 5988-2567EN).

8673B/C/D synthesized signal generators

Like the 8340B/41B, the 8673B/C/D synthesized signal generators are designed for demanding applications requiring high spectral purity stability and frequency accuracy. The 8673B covers 2 to 26 GHz, the 8673C covers 50 MHz to 18.6 GHz, and the 8673D covers 50 MHz to 26 GHz.

Broad frequency coverage and complete programmability combine with excellent AM, FM, and pulse modulation to make them ideal for many millimeter wave signal simulation applications (using the 8349B microwave amplifier and the 83550-series millimeter-wave source modules).

At millimeter-wave frequencies, for AM and pulse performance and the 0.5 V/GHz output, the existing 8673B/C/D may need modifications. Retrofit kits, part number 08673-60130 for 8673B, part number 08673-60182 for 8673C and part number 08673-60183 for 8673D, cover the modifications. The 8673B/C/D standard units shipped after September 1, 1986 will include all modifications necessary.

For detailed information refer to the 8673B/C/D data sheet (publication number 5954-7361).

8757D scalar network analyzer

Optimize your scalar analysis system to meet your specific measurement requirements. The Agilent 8757D measurement features provide great system versatility and measurement throughout. This network analyzer forms the basis of a complete Agilent scalar measurement system. System components may be ordered separately, or as a complete package. The basic components of any scalar system include a scalar analyzer, a swept source, a directional bridge or coupler, and detectors. Other accessories such as a plotter, printer, or disk drive (8757D only) can be added to make a complete manual measurement system.

For detailed information, refer to publication number 5091-2471E, the 8757D data sheet.

Waveguide measurement accessories

Agilent Technologies now offers a full line of waveguide measurement accessories (including directional couplers, isolators, loads, shorts, detectors and attenuators). These complement the millimeter-wave sources and analyzers to help implement complete measurement solutions to 110 GHz.

Waveguide detectors

- **R85026A** 26.5 to 40 GHz, WR-28
- **Q85026A** 33 to 50 GHz, WR-22
- **U85026A** 40 to 60 GHz, WR-19
- **85025C** Option K57 50 to 75 GHz, WR-15, must order with 85025C
- **85025C** Option K71 75 to 110 GHz, WR-10, must order with 85025C

Waveguide directional couplers

- **R752/C/D** 26.5 to 40 GHz, 10/20 dB, WR-28
- **Q752/C/D** 33 to 50 GHz, 10/20 dB, WR-22
- **U752/C/D** 40 to 60 GHz, 10/20 dB, WR-19
- **V752C/D** 50 to 75 GHz, 10/20 dB, WR-15
- **W752C/D** 75 to 110 GHz, 10/20 dB, WR-10

Waveguide accessories

- **R365A** waveguide isolator, WR-28
- **Q365A** waveguide isolator, WR-22
- **U365A** waveguide isolator, WR-19
- **V365A** waveguide isolator, WR-15
- **W365A** waveguide isolator, WR-10
- **R910A** fixed load, WR-28
- **Q910A** fixed load, WR-22
- **W910C** fixed load, WR-10
- **Part No. 11644-20015** V/W fixed short, WR-15/10
- **Part No. 85043-80013** anti-static mat
- **Part No. 11644-2004** Q/U fixed short, WR-22/19
- **Part No. 11644-20005** R fixed short, WR-28

Agilent Technologies Test and Measurement Support, Services, and Assistance

Agilent Technologies aims to maximize the value you receive, while minimizing your risk and problems. We strive to ensure that you get the test and measurement capabilities you paid for and obtain the support you need. Our extensive support resources and services can help you choose the right Agilent products for your applications and apply them successfully. Every instrument and system we sell has a global warranty. Support is available for at least five years beyond the production life of the product. Two concepts underlie Agilent's overall support policy: "Our Promise" and "Your Advantage."

Our Promise

Our Promise means your Agilent test and measurement equipment will meet its advertised performance and functionality. When you are choosing new equipment, we will help you with product information, including realistic performance specifications and practical recommendations from experienced test engineers. When you use Agilent equipment, we can verify that it works properly, help with product operation, and provide basic measurement assistance for the use of specified capabilities, at no extra cost upon request. Many self-help tools are available.

Your Advantage

Your Advantage means that Agilent offers a wide range of additional expert test and measurement services, which you can purchase according to your unique technical and business needs. Solve problems efficiently and gain a competitive edge by contracting with us for calibration, extra-cost upgrades, out-of-warranty repairs, and on-site education and training, as well as design, system integration, project management, and other professional engineering services. Experienced Agilent engineers and technicians worldwide can help you maximize your productivity, optimize the return on investment of your Agilent instruments and systems, and obtain dependable measurement accuracy for the life of those products.

**By internet, phone, or fax, get assistance
with all your test & measurement needs**

Online assistance:

www.agilent.com/find/assist

Phone or Fax

United States:
(tel) 1 800 452 4844

Canada:
(tel) 1 877 894 4414
(fax) (905) 282 6495

China:
(tel) 800 810 0189
(fax) 1 0800 650 0121

Europe:
(tel) (31 20) 547 2323
(fax) (31 20) 547 2390

Japan:
(tel) (81) 426 56 7832
(fax) (81) 426 56 7840

Korea:
(tel) (82 2) 2004 5004
(fax) (82 2) 2004 5115

Latin America:
(tel) (305) 269 7500
(fax) (305) 269 7599

Taiwan:
(tel) 080 004 7866
(fax) (886-2) 2545 6723

Other Asia Pacific Countries:
(tel) (65) 375 8100
(fax) (65) 836 0252
Email: tm_asia@agilent.com

Product specifications and descriptions in
this document subject to change without notice.

Copyright © 2001 Agilent Technologies
Printed in USA November 29, 2001
5954-8364



Agilent Technologies