

**Multi-Cell Charger/Discharger**  
**E4370A Multi-Cell Charger/Discharger Mainframe**  
**E4371A Powerbus Load**  
**E4373A Documentation and Software Pack**  
**E4374A 2 A Charger/Discharger Card**  
**E4375A 3 A Charger/Discharger Card**

Data Sheet



Lower costs and increase yield in lithium-ion and lithium-polymer cell forming

|  |   |
|--|---|
| <b>Flexibility</b>                                 | Fully programmable<br>Automatic data collection<br>Data compression   |
| <b>Safety features</b>                             | Probe contact check<br>Programmable charge/discharge limits<br>Hardware watch-dog timer<br>Configurable digital I/O |
| <b>Improved cell manufacturing yield</b>           | Accurate control and measurement  |
| <b>Lowers capital costs and operating expenses</b> | Energy efficient<br>Automated self-calibration<br>Easy maintenance<br>1-year warranty                               |
| <b>Easy system integration</b>                     | Integrated system features<br>Distributed control over LAN<br>Small size<br>Customization available                 |

## Product Description

The Multi-Cell Charger / Discharger (MCCD) is a cost effective solution specifically designed for manufacturers to charge and discharge secondary lithium-ion and lithium-polymer cells.

It has 256 charging and discharging channels each rated at up to 5 V and 3 A.

Each channel has accurate independent control and measurement. Each channel is capable of constant current and constant voltage charging. Additionally each channel has the ability to perform a constant current discharge. A sequence consisting of charging, resting, or discharging steps can be implemented in any combination up to 99 steps.

Charge/discharge sequences can be modified in software, allowing for simple, rapid changes to the manufacturing process without changes to system hardware.

The E4370A Multi-Cell Charger/Discharger Mainframe, E4371A Powerbus Load, and E4374A/75A Charger/Discharger Cards work together as a complete system for forming cells in the production process. Each Multi-Cell Charger/Discharger mainframe can hold four (4) E4374A/75A Charger/Discharger cards. Each E4374A/75A in turn has power and sense connections for 64 cells. A completely filled MCCD therefore can charge and discharge 256 cells at a time. Charging power is supplied to the MCCD by a fixed 24 volt power supply (supplied by the customer). For discharging, a single E4371A Powerbus Load can dissipate power from two E4370A MCCD Mainframes (512 cells).

A standard MCCD system can realize the following benefits:

- Lower operating costs through higher energy efficiency, energy reuse, and lower cooling costs
- Lower capital cost per cell and improved capability because one MCCD replaces many other components
- Improve cell manufacturing yield and quality. The MCCD gives you the tools to increase yield by providing highly accurate control and precise measurements.
- Improve data management through integrated LAN, data compression, and remote monitoring.

### **Easy System Integration**

The MCCD has many integrated system features making it ideal for distributed manufacturing process control. All scanning and measurement capability is already built into each MCCD. Wiring for fixture control, bar coding, or robotics can all be connected to the MCCD. Connected devices can be controlled via the same LAN connection. The MCCD's compact size takes very little space in humidity controlled environments. Heat generated from discharging can be dissipated away from the cells by placing the E4371A powerbus load outside of the environmentally controlled area.

### **Integrated Safety and Protection Features**

Because safety is highly important in lithium-ion cell production, the MCCD is designed with many safety related features. The MCCD has extensive safety features to protect both the cells under formation and the hardware from equipment failure, programming errors, cell failures and other types of external faults.

The MCCD can also communicate its protection status over LAN to other parts of the manufacturing system to implement system-wide monitoring and protection.

The MCCD continuously measures probe contact resistance and detects if contacts are worn, dirty, or broken. The probe-check feature determines when cabling or contact maintenance is needed. When contact failure is detected, the cell is automatically disconnected preventing overcharging or overheating of the cells and its fixture contacts. Remaining cells continue unaffected.

Output regulators include several features to protect the cell from failures in the hardware. Over-voltage, overcurrent, and reverse voltage can be monitored and configured to shut down the cell forming process. As a redundant protection feature, individual fuses are connected in series with each output to protect the system wiring from excessive currents due to reverse cell polarity, cell failure and regulator failure.

Also, in the event of an unexpected software or firmware failure, a built-in hardware "watch-dog" timer will disconnect all cells to prevent overcharging or over-discharging.

To prevent any data loss during an ac power line failure, an uninterruptible power supply (UPS) can be used to provide ac power to the E4370A MCCD mainframe to during the power failure. Also, should a power failure occur which does not effect the MCCD but which causes the Powerbus to drop in voltage, this will be detected by the MCCD as a Powerbus under-voltage condition and the MCCD will pause, thus preventing any further charging or discharging of connected cells.

Additional integrated safety features can be implemented using configurable digital input and output ports. These can be connected to fire sensors and emergency shutoff signals.

### **Accurate Measurements**

The MCCD can monitor several parameters of the cell while charging, discharging, and resting. Accurate 4-wire measurements are made using separate pairs of wires for power and remote voltage sense. Using the remote voltage sensing, measurements are made directly at the cell and eliminate the effect of voltage drops in the power leads.

Built-in measurements include voltage, current, time, internal resistance, ampere-hours, and watt-hours. These measurements are used to adjust the cell forming sequence for safety, reliability, and proper cell forming.

The M CCD measures actual voltage and output current for each channel using a calibrated internal measurement circuit. During charge and discharge, the M CCD continuously measures current, voltage, and time to accumulate amp-hours and watt-hours delivered into, or taken out of, the cell. Thus, accurate amp-hour and watt-hour capacity measurements can be made even when charge current is not constant, such as during constant voltage charging.

The M CCD can also measure ac and dc cell resistance on command or as a step in the forming sequence.

The M CCD measures the ac cell resistance by passing a sinusoidal ac current sequentially through each cell and measuring the cell's output voltage and current. From this information, the M CCD can calculate the ac resistance of the cell. This method is very similar to the method used by LCR meters. Similarly, the M CCD measures the dc cell resistance by passing a pulsed dc current sequentially through each cell.

#### **Manual Control**

The M CCD has a built-in web server with a graphical user interface that is accessed through standard web browsers such as Netscape Navigator or Microsoft Internet Explorer. This graphical user interface allows monitoring of individual cell state, measuring cell voltages and currents while the test is running, and also complete set-up, monitoring, and control of forming sequences. Downloading of data to remote sites is also supported. The graphical user interface is the recommended method of control when evaluating the test system, prototyping a process, or debugging a program. Various set-up states can be stored in the M CCD's non-volatile memory for easy recall at a later time.

#### **Programmable Flexibility**

The M CCD is fully programmable over a LAN. Forming sequences consisting of charging and discharging steps are downloaded to the M CCD via LAN. The M CCD then can be triggered to run the sequence autonomously while collecting and storing measurements from each cell. Data management is simplified by data organization and data compression techniques. Data can be uploaded at completion of a sequence.

#### **Grouping Capability**

The M CCD can be configured as a single unit of up to 256 channels. It can also be configured into groups. Each group acts independent of the other groups so each group can run its own sequence. Up to 8 groups can be configured, and each group can have from 1 to 256 channels. This added flexibility allows more efficient use of system hardware when cell tray size is smaller and multiple trays need to be tested at the same time.

#### **Efficiency**

The high efficiency (typically 80%) regulating circuits save money by 1) reducing electricity required to charge cells and 2) reducing the cooling and ventilation burden because less radiated heat is generated.

#### **Powerbus**

For the charging cycle, each M CCD mainframe requires an external dc power source to power the cells. The external power source connects to the Powerbus terminals on the back of the mainframe.

For the discharging cycle, an E4371A Powerbus Load is required to dissipate excess power from discharging cells.

Additional electricity savings are realized because energy removed from discharging cells is automatically used to simultaneously charge other cells. This energy recycling contributes to cooling and ventilation savings because all of the energy removed from cells is not dissipated in unwanted heat.

#### **Digital I/O**

The MCCD can monitor and stimulate digital I/O connected to it. This simplifies wiring, allows ease of expansion, and is more reliable than a centralized control system.

The MCCD continuously monitors these digital I/O signals for fast fault detection and emergency system shutdown. The 16 Digital I/O signals operate independently so that if there is a problem with the computer or the LAN connection, the protection functions of the MCCD are not compromised.

The digital I/O can also be used as general purpose I/O. Each general purpose digital output is capable of driving either TTL compatible inputs, or driving high power loads, such as solenoids, indicator lights and relays. These are 24 Volt/300 mA compatible open collector outputs.

When pairs of I/O lines are configured as a single optically isolated output it can drive one TTL LS load. Each open collector output is capable of sinking 1.6 mA at 0.4 V, and can be used up to 24 V.

When configured as digital inputs, each is TTL compatible, with built in pull-ups to facilitate contact and switch closure style inputs.

The 16 digital I/O lines do not have to be configured in the same way. Some can be used as optically isolated outputs while others are single-ended I/O. Functions can also be mixed, with some pins being general purpose Digital I/O to provide fixture control, start and stop switches, or control status lights. Others can be dedicated to a specific purpose such as alarms, emergency stop, and temperature and smoke sensors.

#### **RS-232**

The MCCD has two 9-pin RS-232 ports for connection to local peripherals. Under normal operation both ports are available for general purpose communications, and are configurable over the LAN. The RS-232 ports can support peripheral such as printers, bar code readers, local terminals, robots and other types of local additional hardware. Information is sent bi-directionally over LAN between the host computer and the two RS-232 ports through the MCCD. Therefore, system wiring and maintenance is simplified because only the single LAN connection to the MCCD is needed to read from and pass through control information to ports.

#### **Auxiliary Bias Supply**

To further simplify system integration, an isolated auxiliary dc bias is provided to power various actuators, circuits local to the test fixture, or as pull-up to the digital I/O lines. The auxiliary bias is available through a 4 pin detachable connector. The output of this bias can be set between 5 and 24 volts in 0.1 V increments. Total output power of 10 W at any set voltage is available. This auxiliary bias is isolated by up to 42 V with respect to chassis common.

**Maintenance**

Ongoing cost of ownership is lowered because the MCCD is easy to maintain. Fault status can be easily monitored over LAN to identify which unit needs service. Additionally front panel indicators identify which MCCD or charge/discharge card has experienced a fault.

A Charger/Discharger card containing a defective channel can be easily removed and quickly replaced at your convenience. This method of maintenance minimizes downtime by increasing equipment availability and eliminating the need to interrupt production processes.

**Calibration**

A fully automated self-calibration provides a very simple and quick means to calibrate all 256 channels by using a single 3458A DMM in less than 15 minutes. The recommended calibration cycle is 12 months.

Full calibration is a two-step process that consists of mainframe reference calibration, which uses an external voltmeter to calibrate the internal reference voltages in the MCCD mainframe, followed by a transfer calibration, which uses the calibrated internal reference in the mainframe to calibrate all of the channels on the E4374A/75A Charger/Discharger Cards.

During transfer calibration, the calibrated mainframe internal reference voltages are then used to calibrate all E4374A/75A Charger/Discharger cards through internal multiplexing circuitry. Transfer calibration, does not require an external voltmeter. Transfer can be performed whenever an E4374A/75A card is inserted into the MCCD to ensure the new or replacement card is calibrated to specifications.

During normal operation, continuous calibration is performed on the individual programming circuits during the entire charge/discharge sequence to eliminate errors due to temperature drift.

**Warranty and Service**

The MCCD comes with a full 1-year return to warranty. Other custom service plans to extend warranty or to provide on-site services are also available.

To maximize manufacturing system uptime, Agilent recommends that you consider spare system components. Since the MCCD system is modular, a small number of spare system components will support a large number of on-line systems, thus allowing your own maintenance personnel to quickly replace any faulty units and restore production within minutes.

These spares, your maintenance personnel, and support services from Agilent can be combined to form a support plan to meet your specific needs and budget. See your Field Sales Engineer for a quotation on price and availability of support services in your area.

**System diagram**

The following diagram illustrates an example of how the built-in features of the MCCD simplifies system integration in a factory environment. A single LAN connection is all that is required to control charging, discharging,

measurement acquisition, bar-code readers, fixture, and material handler. An additional benefit is that manufacturing down-time is minimized because each MCCD runs independently from the others.

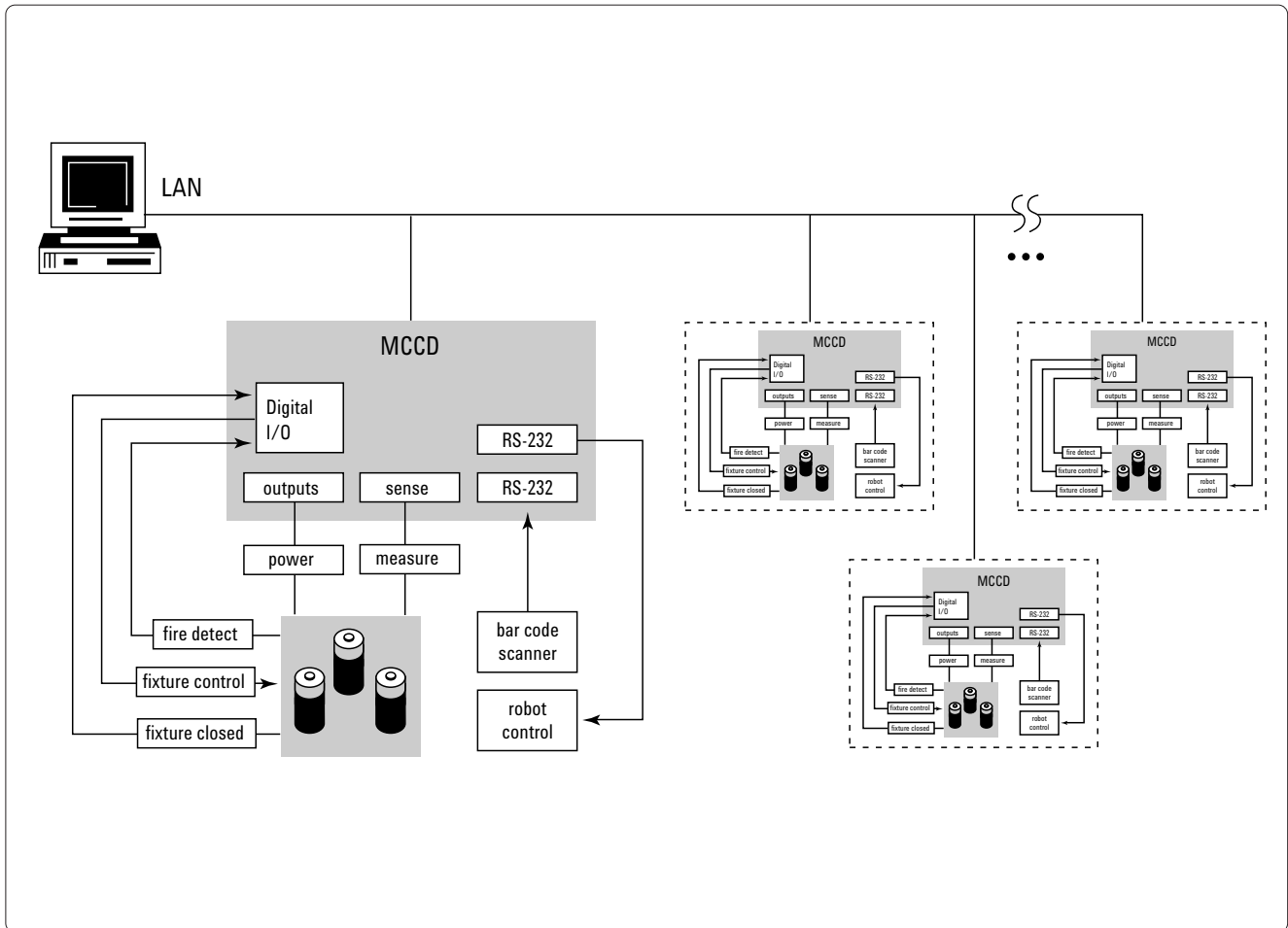

## Specifications

**Table A-1. E4370A/E4374A/E4375A MCCD Specifications**

| <b>Hardware Specifications</b>  | <b>Parameter</b>  | <b>Condition</b>  | <b>Value for<br/>E4370A + E4374A</b>   | <b>Value for<br/>E4370A + E4375A</b>                       |
|---|---|---|--|--|
| <i>Specifications in Table A-1 are warranted. Specifications apply over an ambient temperature range of 0°C to 40°C. When charging, specifications apply for charging voltages from 0.5 V to maximum, and charge currents from minimum to maximum. When discharging, specifications apply for discharging voltages from 1.5 V to maximum and discharging currents from minimum to maximum. Accuracy specifications apply over the entire range of ac line and power bus conditions (line regulation), and charging/discharging levels (load regulation). Specifications are subject to change without notice.</i> | <b>Maximum Programmable Output Voltage</b>                                      | charging  | 5 V  | 5 V  |
|   | <b>Maximum Compliance Voltage (cell voltage + fixture/wiring voltage drops)</b> | charging  | 5.5 V  | 6 V  |
|   | <b>Maximum Programmable Output Current</b>                                      | charging or discharging, per channel                            | 2 A  | 3 A  |
|   | <b>Minimum Output Current<sup>1</sup></b>                                       | constant voltage charging and discharging                       | 0 A  | 0 A  |
|   | <b>Maximum Output Leakage Current</b>   | disabled, per channel, with an external voltage of -5 V to +5 V | ±25 µA   | ±25 µA   |
|   | <b>Maximum Power</b>  | charging, per channel<br>discharging, per channel               | 11 W<br>9 W  | 18 W<br>13.5 W   |
|   | <b>Maximum Input Voltage</b>  | discharging   | 4.5 V  | 4.5 V  |
|   | <b>Voltage Programming Accuracy</b>   | measured at sense connector input with remote sensing           | ±1 mV  | ±1 mV  |
|   | <b>Voltage Readback Accuracy</b>  | measured at sense connector input with remote sensing           | ±1 mV  | ±1 mV  |
|   | <b>Current Programming Accuracy</b>   | % of reading + offset   | ≤1 A ±(0.05% + 1 mA)<br>1 A to ≤2 A ±(0.1% + 1 mA)<br>>2 A ±(0.15% + 1.5 mA) | ±(0.05% + 1.5 mA)<br>±(0.1% + 1.5 mA)<br>±(0.15% + 1.5 mA) |
|   | <b>Current Readback Accuracy</b>  | % of reading + offset   | ≤1 A ±(0.05% + 1 mA)<br>1 A to ≤2 A ±(0.1% + 1 mA)<br>>2 A ±(0.15% + 1.5 mA) | ±(0.05% + 1.5 mA)<br>±(0.1% + 1.5 mA)<br>±(0.15% + 1.5 mA) |
|   | <b>ac Resistance Measurement Accuracy</b>                                       | % of reading + offset   | ±(1% + 1 mΩ)   | ±(1% + 1 mΩ)   |
|   | <b>dc Resistance Measurement Accuracy</b>                                       | % of reading + offset   | ±(1% + 1 mΩ)   | ±(1% + 1 mΩ)   |

**Notes:**

<sup>1</sup> There is a minimum programmable current limit when operating in constant current (CC) mode. In CC, the output cannot be set to run below the minimum programmable constant current limit specified in the table A-2. In constant voltage (CV) charge or discharge, the MCCD will regulate current down to 0 A.

**Table A-2. E4370A/E4374A/E4375A MCCD Characteristics**

| Parameter   | Condition   |              | Value for<br>E4370A + E4374A                             | Value for<br>E4370A + E4375A                             |
|---|---|--------------|--|--|
| <b>ac Resistance Measurement</b>  | maximum measurable<br>maximum time per output to measure <sup>1</sup>   |              | 1 Ω<br>1 s   | 1 Ω<br>1 s   |
| <b>dc Resistance Measurement</b>  | maximum measurable<br>maximum time per output to measure <sup>1</sup>   |              | 1 Ω<br>1 s   | 1 Ω<br>1 s   |
| <b>Ah Capacity Measurement Accuracy</b>   | % of reading + offset   | ≤2 A<br>>2 A | ±(0.1% + 1 mAh/h)  | ±(0.10% + 1.5 mAh/h)<br>±(0.15% + 1.5 mAh/h)             |
| <b>Wh Capacity Measurement Accuracy</b>   | % of reading + offset   | ≤2 A<br>>2 A | ±(0.1% + 5 mWh/h)  | ±(0.10% + 7.5 mWh/h)<br>±(0.15% + 7.5 mWh/h)             |
| <b>Maximum Deviation of Measured Output Current from Programmed Output Current</b>      | constant current mode   |              | ±2 mA  | ±3 mA  |
| <b>Maximum Deviation of Measured Output Voltage from Programmed Output Voltage</b>      | constant current mode   |              | ±2 mV  | ±2 mV  |
| <b>Voltage Output Noise<sup>2</sup></b>   | rms<br>peak-to-peak   |              | 30 mV<br>100 mV  | 30 mV<br>100 mV  |
| <b>Current Output Noise<sup>2</sup></b>   | rms<br>peak-to-peak   |              | 1 mA<br>10 mA  | 10 mA<br>10 mA   |
| <b>Maximum Current Overshoot/Undershoot from first applied programmed current level</b> | when programmed current of <50 mA is first applied<br>when programmed current of >50 mA is first applied                        |              | ±15 mA for up to 500 ms<br>5% for up to 5 ms             | ±15 mA for up to 500 ms<br>5% for up to 5 ms             |
| <b>Maximum Voltage Overshoot/Undershoot</b>   |   |              | ±25 mV   | ±25 mV   |
| <b>Maximum Current Risetime</b>   |   |              | 0.1 s  | 0.1 s  |
| <b>Minimum Programmable Constant Current Limit</b>                                      | constant current charging and discharging mode  |              | 25 mA  | 25 mA  |
| <b>Measurement Interval</b>   | for data logging<br>for sequence tests<br>for probe check per channel <sup>3</sup>  |              | 1 s<br>1 s<br>1 s  | 1 s<br>1 s<br>1 s  |
| <b>Step Time</b>  | maximum<br>minimum<br>resolution  |              | 596 hours<br>7 s<br>1 s                                  | 596 hours<br>7 s<br>1 s                                  |
| <b>Maximum Number of Readings in Data Buffer</b>  |   |              | 349,504  | 349,504  |
| <b>Maximum Sequence Length</b>  |   |              | 596 hours  | 596 hours  |
| <b>Maximum Number of Steps in Sequence</b>  |   |              | 100  | 100  |
| <b>ac Input Line Requirements</b>   | input voltage range<br>input frequency range<br>maximum input power<br>max. current @ 100/120 Vac<br>max. current @ 220/240 Vac |              | 95 Vac - 250 Vac<br>47 Hz - 63 Hz<br>300 W<br>4 A<br>2 A | 95 Vac - 250 Vac<br>47 Hz - 63 Hz<br>300 W<br>4 A<br>2 A |

**Notes:**<sup>1</sup>To measure 256 cells takes up to 5 minutes.<sup>2</sup>At the power connector, with a bandwidth of 20 Hz to 20 MHz.<sup>3</sup>To measure output probe resistance accurately there must be 50 mV between the ± power leads and the ± sense leads. To measure sense probe resistance accurately there must be 100 mV of cell voltage.

Tables A-2 through A-4 list the supplemental characteristics of the E4370A/E4374A/E4375A/E4371A MCCD System. Requirements for the external power bus source are also listed. Characteristics are not warranted but are descriptions of typical performance determined either by design or by type testing.

**Table A-2.** E4370A/E4374A/E4375A MCCD Characteristics (continued)

| Parameter   | Condition   | Value for<br>E4370A + E4374A                       | Value for<br>E4370A + E4375A                       |
|---|---|--|--|
| <b>Maximum Sense Probe Resistance<sup>3</sup></b> |   | 1 k $\Omega$                                       | 1 k $\Omega$                                       |
| <b>Auxiliary bias output power</b>                | maximum @ 5 to 24 V/0.42 to 2 A                                 | 10 W   | 10 W   |
| <b>Auxiliary bias output voltage</b>              | maximum @ 0 to 0.42 A<br>minimum @ 0 to 2 A                     | 24 V<br>5 V  | 24 V<br>5 V  |
| <b>Auxiliary bias output current</b>              | maximum @ 5 V output<br>minimum @ 24 V output                   | 2 A<br>0.42 A                                      | 2 A<br>0.42 A                                      |
| <b>Auxiliary bias output voltage accuracy</b>     | % of setting at any voltage and current                         | 7 %  | 7 %  |
| <b>Auxiliary bias output noise</b>                | peak to peak at any voltage and current                         | 100 mV   | 100 mV   |
| <b>Non-isolated Digital I/O Characteristics</b>   | maximum low-level output voltage                                | 0.4 V @ 20 mA sink<br>1 V @ 300 mA sink            | 0.4 V @ 20 mA sink<br>1 V @ 300 mA sink            |
|   | minimum high-level output voltage                               | 3.5 V @ 0 mA source<br>2.6 V @ -200 $\mu$ A source | 3.5 V @ 0 mA source<br>2.6 V @ -200 $\mu$ A source |
|   | maximum high-level output current                               | 250 $\mu$ A @ Voh = 24 V                           | 250 $\mu$ A @ Voh = 24 V                           |
|   | minimum high-level input voltage                                | 2.1 V  | 2.1 V  |
|   | maximum low-level input voltage                                 | 0.5 V  | 0.5 V  |
|   | maximum high-level input current                                | 0.8 mA @ Vih min.                                  | 0.8 mA @ Vih min.                                  |
| <b>Isolated Digital I/O Characteristics</b>       | max. low-level output voltage<br>max. high-level output current | 0.6 V<br>100 $\mu$ A                               | 0.6 V<br>100 $\mu$ A                               |
| <b>Maximum Airflow</b>                            | cubic meters per minute<br>cubic feet per minute                | 7.1<br>250   | 7.1<br>250   |
| <b>Maximum Exhaust Air Temperature Rise</b>       | from inlet air to exhaust air                                   | 8 °C   | 8 °C   |
| <b>Dimensions</b>                                 | Height<br>Width<br>Depth  | 221.5 mm<br>425.5 mm<br>540.5 mm                   | 221.5 mm<br>425.5 mm<br>540.5 mm                   |
| <b>Weight</b>                                     | for 1 mainframe with 4 cards                                    | 22 kg  | 22 kg  |

**Notes:**

<sup>1</sup> To measure 256 cells takes up to 5 minutes.

<sup>2</sup> At the power connector, with a bandwidth of 20 Hz to 20 MHz.

<sup>3</sup> To measure output probe resistance accurately there must be 50 mV between the  $\pm$  power leads and the  $\pm$  sense leads. To measure sense probe resistance accurately there must be 100 mV of cell voltage.

**Table A-3.** E4371A Powerbus Load Characteristics

| <i>Use this information when integrating the E4371A Powerbus Load into your system.</i> | <b>Parameter</b>  | <b>Condition</b>                                 | <b>Value</b>                     |
|---|---|--|----------------------------------|
|   | <b>Recommended Maximum Power Dissipation</b>                      |  | 5,400 W                          |
|   | <b>Normal Input Voltage</b>                                       |  | 26.5 - 27 Vdc                    |
|   | <b>Recommended Maximum Input Current</b>                          |  | 200 A                            |
|   | <b>Maximum Wiring Voltage Drop between MCCD and Powerbus Load</b> | at maximum current                               | 1.5 V                            |
|   | <b>Maximum Exhaust Air Temperature Rise</b>                       | from inlet air to exhaust air                    | 40°C                             |
|   | <b>Maximum Airflow</b>  | cubic meters per minute<br>cubic feet per minute | 10<br>350                        |
|   | <b>Dimensions</b>   | Height<br>Width<br>Depth                         | 221.5 mm<br>425.5 mm<br>540.5 mm |
|   | <b>Weight</b>   |  | 22.7 kg                          |

**Table A-4.** Requirements for External Power Bus Source

|  | <b>Parameter</b>  | <b>Condition</b>   | <b>Value</b>    |
|--|---|--|-----------------|
|  | <b>Nominal Output Voltage</b>   |  | 24 Vdc          |
|  | <b>Output Voltage Range</b>   |  | 22.8 - 25.2 Vdc |
|  | <b>Voltage Output Noise</b><br>Measured at the output, with a bandwidth of 20 Hz to 20 MHz. | rms<br>peak-to-peak  | 30 mV<br>100 mV |
|  | <b>Maximum Output Current</b>   | for one MCCD mainframe with 256 channels charging @ 5 V, 2 A per channel | 133 A           |
|  |   | for one MCCD mainframe with 256 channels charging @ 5 V, 3 A per channel | 213 A           |
|  | <b>Maximum Output Power</b>   | for one MCCD mainframe with 256 channels charging @ 5 V, 2 A per channel | 3200 W          |
|  |   | for one MCCD mainframe with 256 channels charging @ 5 V, 3 A per channel | 5120 W          |

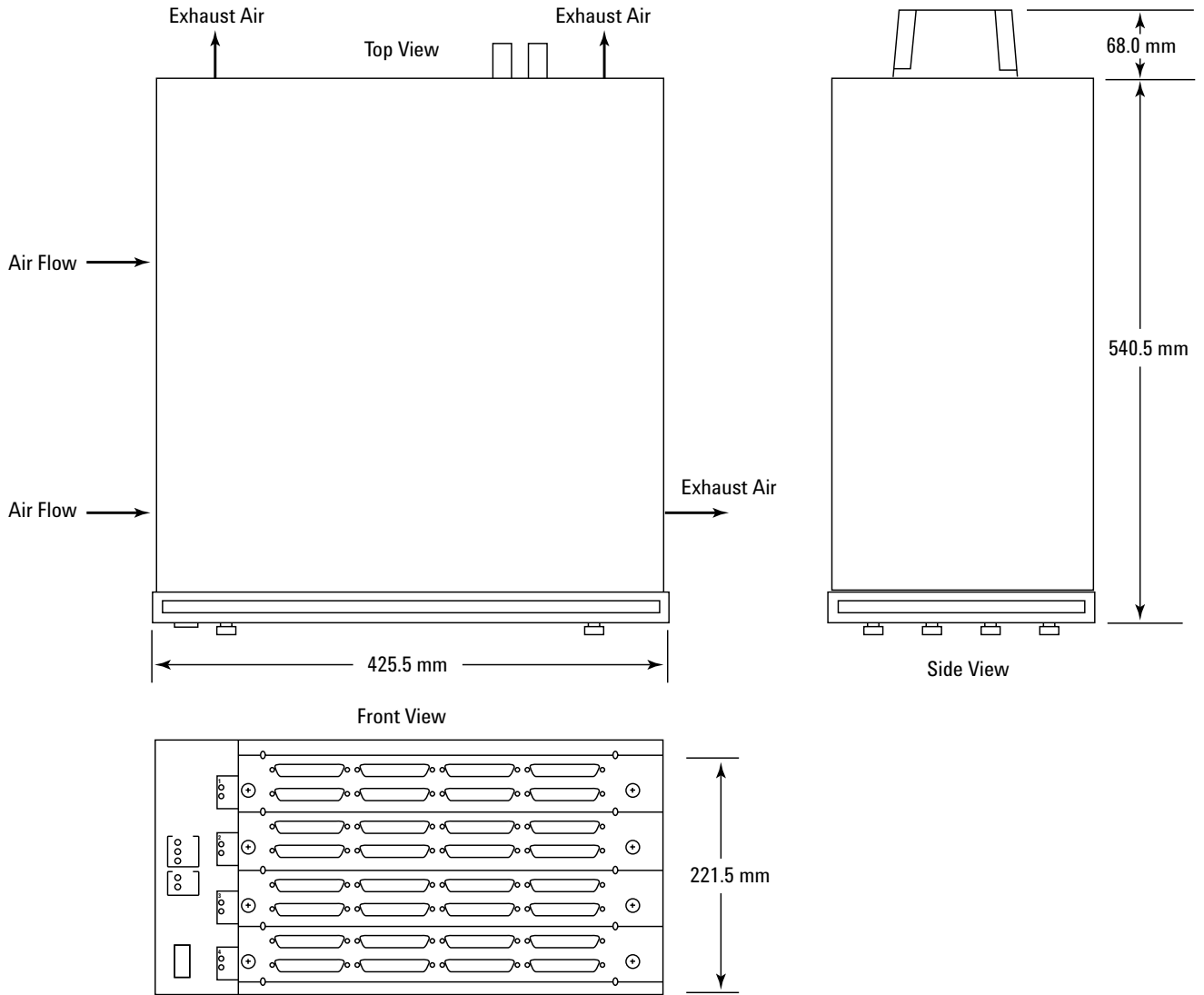

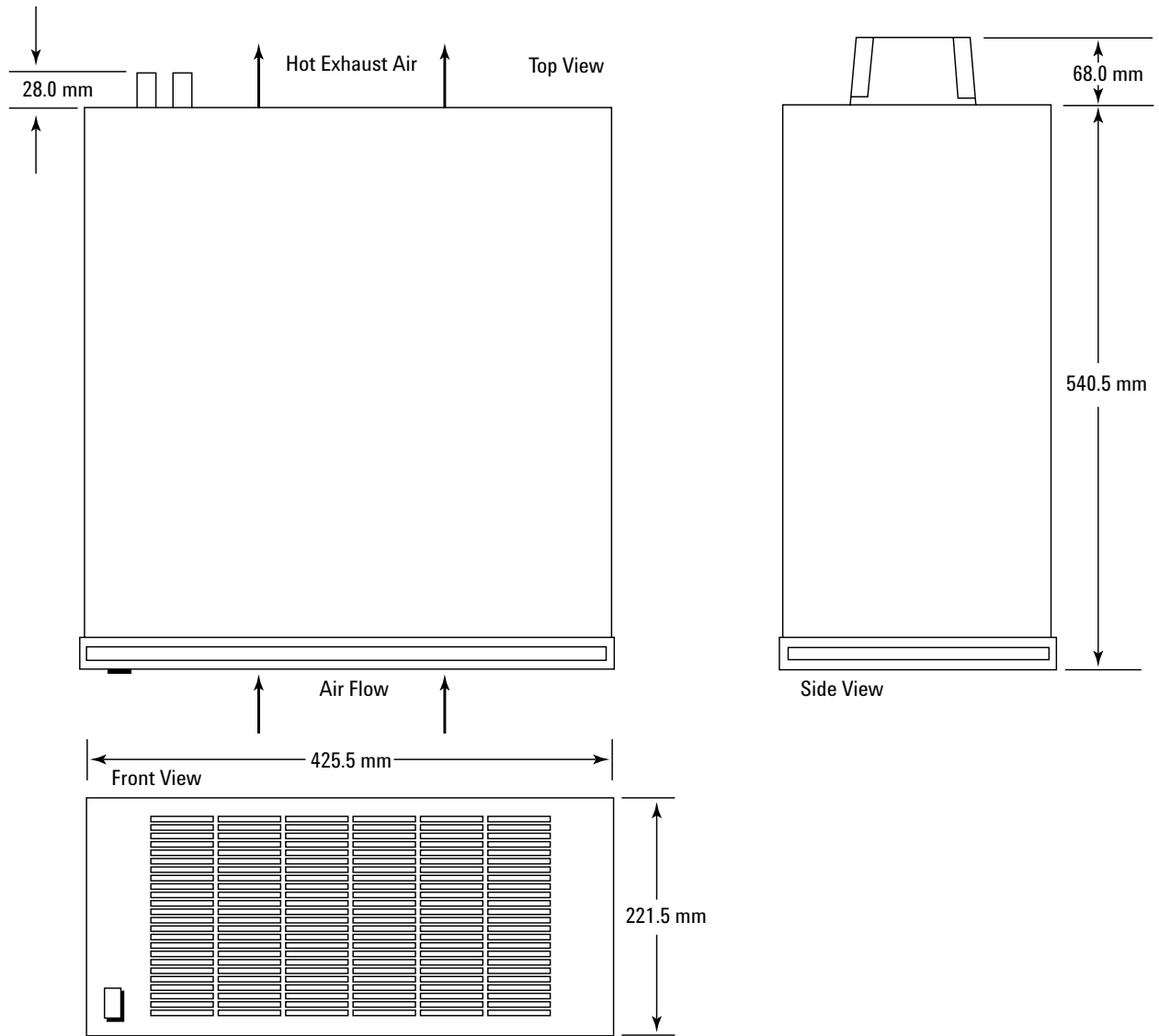

## Ordering Information

| Model      | Description   |
|------------|---|
| E4370A     | MCCD Mainframe  |
| Option 202 | Specifies standard features with air filters for MCCD system. |
| E4371A     | Powerbus Load   |
| E4374A     | 2 A Charger/Discharger Card                                   |
| Option 002 | Standard E4374A card with only 48 channels                    |
| E4375A     | 3 A Charger/Discharger Card                                   |

## Accessories

| Item and Part Number  | Equivalent Manufacturer's Part Number                                     | Description of Accessory  |
|---|---|---|
| <b>Documentation Package</b><br>Model Number E4373A                                   |   | Contains user documentation, software drivers, and utility programs for Windows NT, Windows 9x, MS Visual C++ version 4.x or 5.x    |
| <b>Serial Cable</b><br>Model Number 34398A  |   | RS-232 null-modem cable for MCCD Mainframe port A or B. Contains DB9 null-modem cable with DB25 adapter.                            |
| <b>Power and Sense Connectors</b><br>(8 connectors are required for each E4374A card) | AMP 205210-2<br>AMP 749916-2<br>AMP 66506-9<br>AMP 58448-2<br>AMP 66570-2 | 37 pin male connector<br>Hood for connector<br>Crimp style contacts<br>Crimp tool for crimp style contacts<br>Solder style contacts |
| <b>Digital I/O Connector</b>  | Phoenix MSTB-2.5/10-STF   | 10-pin terminal plug for Digital I/O<br>2 required per E4374A   |
| <b>Aux Bias/Calibration Connector</b>   | Phoenix MSTB-2.5/4-ST   | 2 - 4-pin terminal plug for Aux Bias and Calibration Port<br>2 required per E4370A  |
| <b>Blank Filler Panel</b><br>Part Number 5002-1505                                    |   | Note: 1 Blank Filler Panel is required for every empty slot in E4370A MCCD Mainframe.   |

Individual connectors, parts, and tools can also be purchased by contacting the following individual vendors for distributors of their products in your geographical area:

|                        |   |
|------------------------|---|
| <b>Phoenix Contact</b> | <a href="http://www.phoenixcontact.com">http://www.phoenixcontact.com</a> |
| <b>AMP</b>             | <a href="http://www.amp.com">http://www.amp.com</a>                       |

## Selecting an ac Line Cord

The E4370A MCCD Mainframe has a universal input power supply, rated at 95 Vac to 250 Vac, 43 Hz to 63 Hz. Therefore, it is compatible with most ac mains.

Based on the country to which the MCCD is being shipped, will automatically select a default line cord. This table shows the default line cord selections.

**Note:** If this default line cord selection is not appropriate for your application, please contact your Field Sales Engineer and specify what line cord you would like for your MCCD.

**Example:** The default line cord for the US is Option #903, which connects the MCCD to the 120 Vac mains. For your application, you've decided that you want to connect the MCCD to the same ac mains as the rest of the industrial equipment in your forming process. Therefore, you would like a line cord to connect the MCCD to 240 Vac mains, rather than the 120 Vac mains. Contact your Field Sales Engineer so can provide the appropriate line cord for this connection.

| Country   | AC Line Voltage                                | Option | Plug Diagram |
|---|--|--------|--------------|
| Hong Kong<br>Malaysia<br>Singapore<br>UK                    | 220<br>240<br>230<br>230                       | 900    |              |
| Continental Europe<br>Indonesia<br>S. Korea                 | 230<br>220<br>220                              | 902    |              |
| Brazil<br>Canada<br>Philippines<br>Taiwan<br>Thailand<br>US | 120/220<br>120<br>120/220<br>120<br>220<br>120 | 903    |              |
| Switzerland   | 230  | 906    |              |
| Denmark   | 230  | 912    |              |
| India   | 240  | 917    |              |
| Japan   | 100  | 918    |              |
| Israel  | 220  | 919    |              |
| China   | 220  | 922    |              |

L = Line or active conductor  
(also called "live" or "hot")  
N = Neutral or Identified Conductor  
E = Earth or Safety Ground

[www.agilent.com](http://www.agilent.com)

**Agilent Technologies' Test and Measurement Support, Services, and Assistance**

Agilent Technologies aims to maximize the value you receive, while minimizing your risk and problems. We strive to ensure that you get the test and measurement capabilities you paid for and obtain the support you need. Our extensive support resources and services can help you choose the right Agilent products for your applications and apply them successfully. Every instrument and system we sell has a global warranty. Support is available for at least five years beyond the production life of the product. Two concepts underlie Agilent's overall support policy: "Our Promise" and "Your Advantage."

**Our Promise**

Our Promise means your Agilent test and measurement equipment will meet its advertised performance and functionality. When you are choosing new equipment, we will help you with product information, including realistic performance specifications and practical recommendations from experienced test engineers. When you use Agilent equipment, we can verify that it works properly, help with product operation, and provide basic measurement assistance for the use of specified capabilities, at no extra cost upon request. Many self-help tools are available.

**Your Advantage**

Your Advantage means that Agilent offers a wide range of additional expert test and measurement services, which you can purchase according to your unique technical and business needs. Solve problems efficiently and gain a competitive edge by contracting with us for calibration, extra-cost upgrades, out-of-warranty repairs, and on-site education and training, as well as design, system integration, project management, and other professional engineering services. Experienced Agilent engineers and technicians worldwide can help you maximize your productivity, optimize the return on investment of your Agilent instruments and systems, and obtain dependable measurement accuracy for the life of those products.



**Agilent Email Updates**

[www.agilent.com/find/emailupdates](http://www.agilent.com/find/emailupdates)

Get the latest information on the products and applications you select.

**By internet, phone, or fax, get assistance with all your test & measurement needs**

**Online assistance:**  
[www.agilent.com/find/assist](http://www.agilent.com/find/assist)

**Phone or Fax**

**United States:**

(tel) 1 800 452 4844

**Canada:**

(tel) 1 877 894 4414

(fax) (905) 282 6495

**China:**

(tel) 800 810 0189

(fax) 800 820 2816

**Europe:**

(tel) (31 20) 547 2323

(fax) (31 20) 547 2390

**Japan:**

(tel) (81) 426 56 7832

(fax) (81) 426 56 7840

**Korea:**

(tel) (82 2) 2004 5004

(fax) (82 2) 2004 5115

**Latin America:**

(tel) (305) 269 7500

(fax) (305) 269 7599

**Taiwan:**

(tel) 0800 047 866

(fax) 0800 286 331

**Other Asia Pacific Countries:**

(tel) (65) 6375 8100

(fax) (65) 6836 0252

Email: [tm\\_asia@agilent.com](mailto:tm_asia@agilent.com)

Product specifications and descriptions in this document subject to change without notice.

© Agilent Technologies, Inc. 2002

Printed in the USA March 29, 2002

5988-3304EN



**Agilent Technologies**