

Agilent 8509C Lightwave Polarization Analyzer

Product Overview

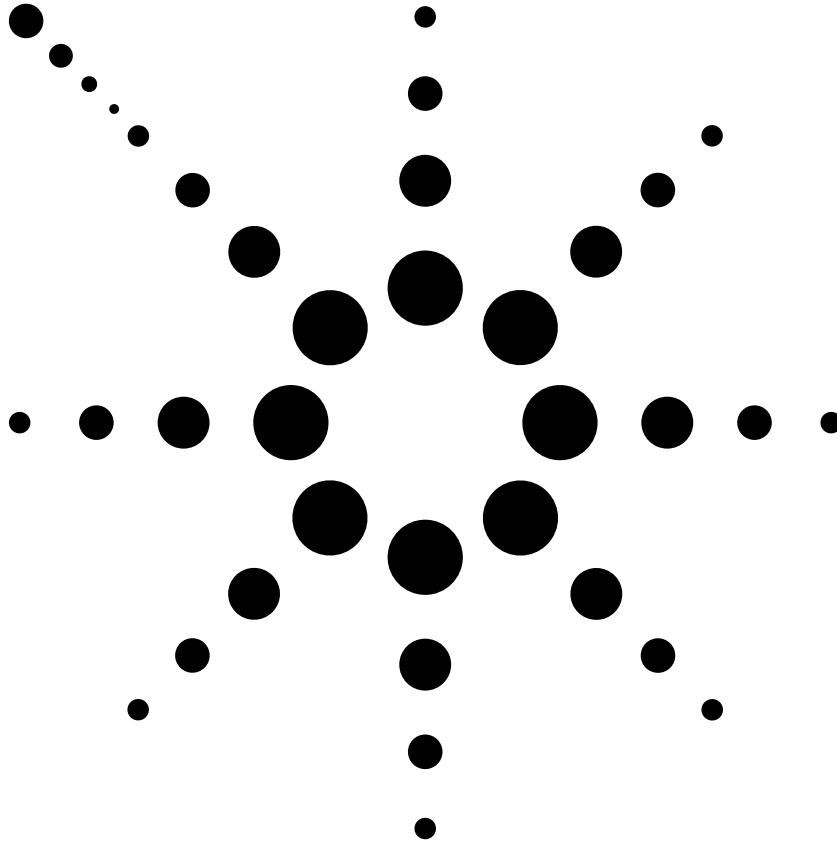
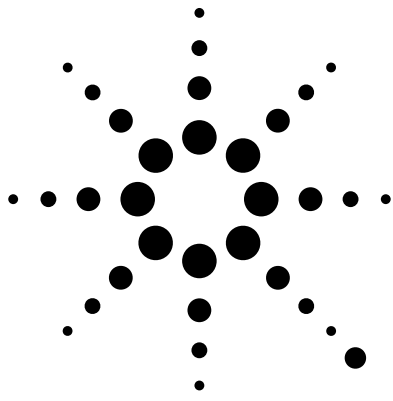

**Highly accurate and repeatable polarization
measurements of signal and components**

1280 nm to 1640 nm

- **L-Band extended wavelength option**
- **High resolution and accuracy on narrowband devices**
- **Fast measurement capability**

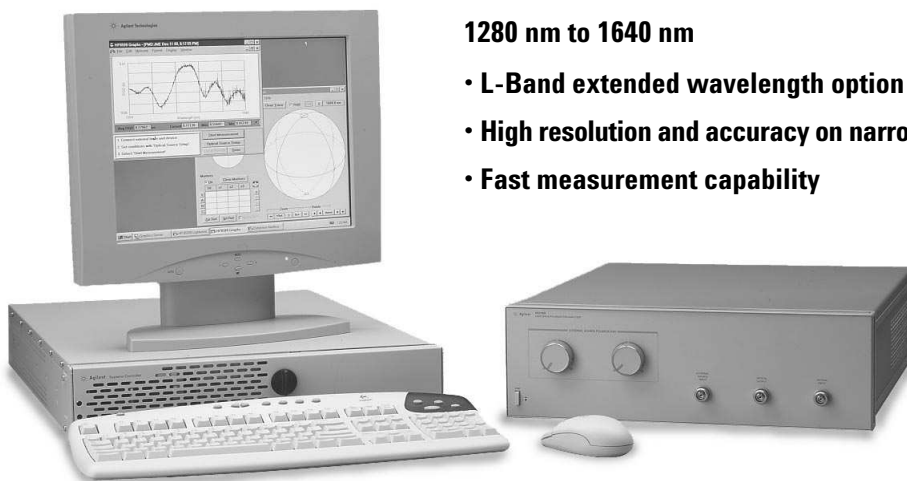

Agilent Technologies

The Agilent 8509C Lightwave Polarization Analyzer

The Agilent 8509C lightwave polarization analyzer offers high-speed, calibrated polarization measurements of both optical signals and components. These capabilities are provided by innovations in hardware, software, and applications of Jones matrix and Stokes vector mathematics.

The 8509C analyzer facilitates a greater understanding of the polarization properties of lightwave signals and materials in helping to develop higher performance lightwave components and systems, as well as more effective test and manufacturing processes. These developments involve many types of polarization-sensitive devices which are used in communications, sensors, optical computing and material analysis; devices such as single-mode fibers, polarization-maintaining fibers, isolators, optical switches, lasers, beamsplitters, modulators, interferometers, retardation plates and, of course, polarizers and polarization adjusters.

Polarization characteristics affect all lightwave transmissions. The polarization of a lightwave signal is defined by its E-field components. As a signal propagates, interaction with optical components and other lightwave signals (in interferometric applications) modifies the magnitude and phase of the signal's E-field components. Polarization-dependent loss, gain or even signal distortion may occur depending on the application.

Polarization mode dispersion (PMD) is a key hurdle limiting the transmission of signals at 10 Gbit/s and above. The Agilent 8509C lightwave polarization analyzer, in conjunction with the Agilent 8164 series tunable laser source or the Agilent 81680 laser, can be used to measure PMD of fiber and components down to 1 fs resolution.

Key Customer Benefits

Measurement capabilities: Polarization Mode Dispersion (PMD), Polarization Dependent Loss (PDL), Polarization Maintaining Fiber (PMF) launch alignment (polarization cross talk), Degree of Polarization (DOP), Stokes Parameters and Average power measurements.

Wide wavelength range: 1280-1640 nm S, C and L band coverage.

Polarization mode dispersion accuracy: ± 0.05 ps (50fs)

Polarization mode dispersion measurement range: 0.01 ps (10 fs) to 400 ps. Measure very low PMD using the highly accurate Jones Matrix Eigenanalysis (JME) method. PMD measurements can also be made using the Fixed Analyzer (or wavelength scanning) method.

Wide dynamic range: +10 dBm to -55 dBm

High-speed measurements: Polarization measurement rate of > 3500 points per second.

Operation verification: An automated internal process that allows the customer to check the basic functions of the analyzer in order to obtain the highest possible accuracy in PMD measurements.

PMD statistics: PMD statistics window allows viewing of PMD statistics. A Maxwell curve is automatically fitted to the data and the parameters that define the shape of the fitted Maxwell curve is displayed.

Low PDL measurements: 0.05 dB. PDL measurement using JME and power max-min methods.

1 pm relative wavelength accuracy (with Agilent 86120C wavelength meter) - It allows very precise characterization of optical components and fiber for chromatic dispersion.

0.1 pm wavelength resolution - The best resolution on the market. This allows for optical fiber and component manufacturers to measure their devices with very small step sizes.

Easy PMD measurements of optical fiber and components - large measurement dynamic range. Ability to measure very small dispersion values.

Expert applications support - Experienced Agilent engineers and technicians at technical support centers worldwide can help you maximize your productivity, optimize return on investment on your lightwave polarization analyzer and obtain dependable measurement accuracy for the life of the product.

Accurate, easy-to-understand data in less time

In order to maintain a competitive edge, R&D and manufacturing operations need fast, accurate, easy-to-understand measurement data. This reduces the time and expense of bringing a product to market. The Agilent 8509C can help.

Test times are reduced by the system's versatile and powerful combination of hardware and software technology. A four-diode detection scheme delivers real-time polarization information. Polarization control is available using the automatic, three-state polarization generator. Polarization mode dispersion and polarization-dependent loss measurements are quick and simple using the 8509C automatic measurement procedures.

Measurement accuracy is provided by the system's accuracy enhancement techniques. The 8509C polarization reference frame enables accurate testing in bulk optics by removing unwanted fiber cable effects. The 8509C wavelength calibration capability automatically optimizes the system receiver for the best performance based on the polarization and wavelength of a test signal.

Polarization is easier to understand when data is presented in the appropriate display formats. When tuning the polarization of a light-wave signal, for example, the Poincare sphere is the best format because the tuning process is visually guided by a moving polarization trace on the sphere. For mathematical specifications of signal polarization, the Stokes parameter format is best because it is used in polarization calculations.

Whichever format is needed, the 8509C can meet the need with simultaneous data displays in a variety of different formats.

In the lab and on the production line, scientists, engineers and technicians depend on the speed, accuracy and convenience of the 8509C to measure and predict the polarization of signals and the polarization transmission properties of components.

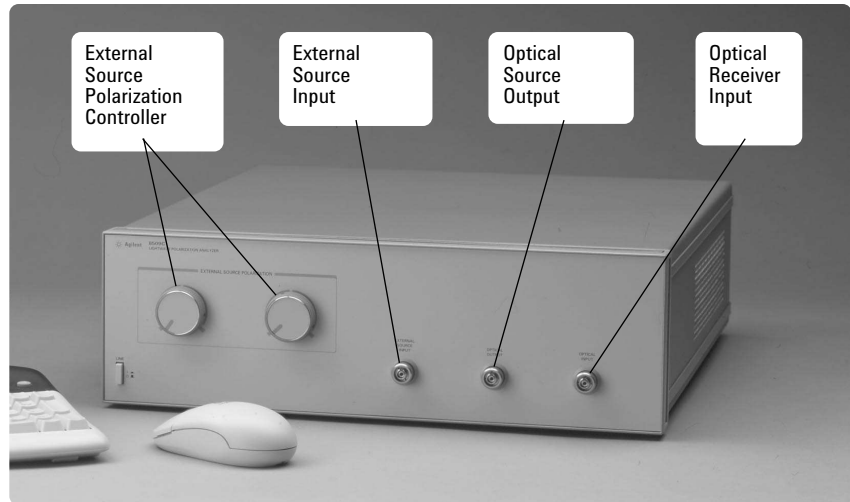

8509C measurement capability and data format summary

- **Polarization Ellipse**
- **Poincare Sphere**
- **Stokes Parameters**
- **Degree of Polarization**
- **Average Power**
- **Jones Matrix**
- **Polarization Mode Dispersion**
- **Polarization-Dependent Loss**
- **Polarization-Maintaining-Fiber Launch Conditions**

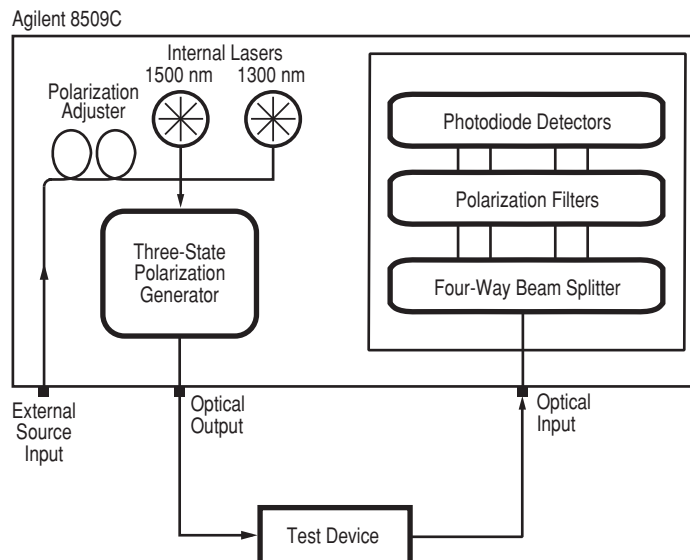

Figure 1. 8509C block diagram

Measure optical signal polarization

Increase accuracy and make polarization easier to understand with polarization reference frame procedures and multiple, simultaneous display formats.

State of Polarization

In fiber cables and bulk-optics, the 8509C delivers high-speed signal polarization analysis by performing approximately 3000 polarization measurements per second. Data averaging can be applied before it is displayed as average power, polarization ellipse, Stokes parameters and points on a Poincare sphere. Three data markers provide Stokes parameter analysis and relative angle comparisons between specific data points on the Poincare sphere.

Polarization Reference Frame

Polarization reference frames are especially valuable for open beam applications where location-specific signal polarization information is needed. In these cases the test system must remove its own responses from the test data to minimize measurement uncertainty.

The 8509C quickly defines a polarization reference frame at a specific location using three polarizer angles. The absolute polarization accuracy of the reference frame depends largely on the standards used.

Jones Matrix

A 2 X 2 complex Jones matrix, measured by the 8509C, mathematically describes how an individual optical component will affect the intensity and polarization of a transmitted signal.

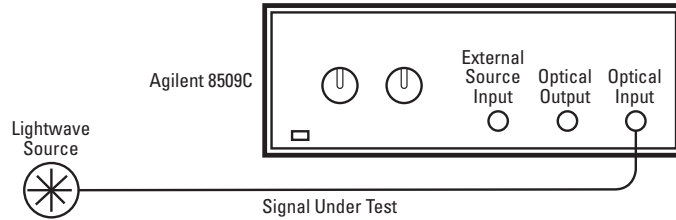

Figure 2. Signal polarization measurement setup

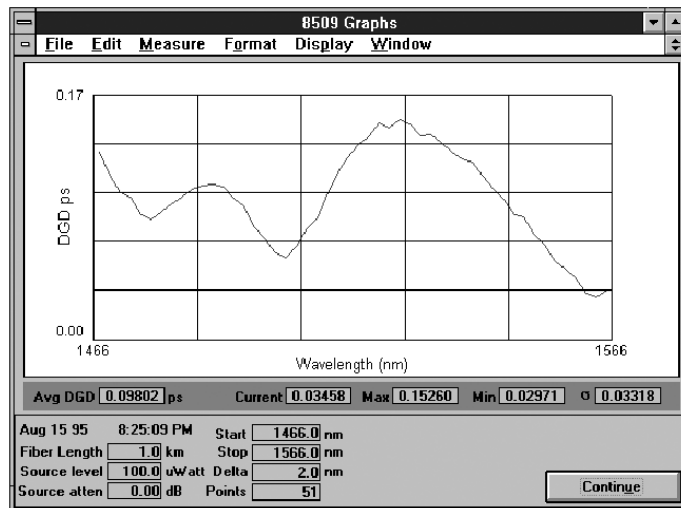

Figure 3. Typical JME PMD measurement of a fiber spool. The differential group delay (DGD) varies with wavelength. The average DGD value, also called the *PMD Delay*, is displayed directly below the graph, along with the DGD statistics. Setup conditions are displayed at the bottom of the screen.

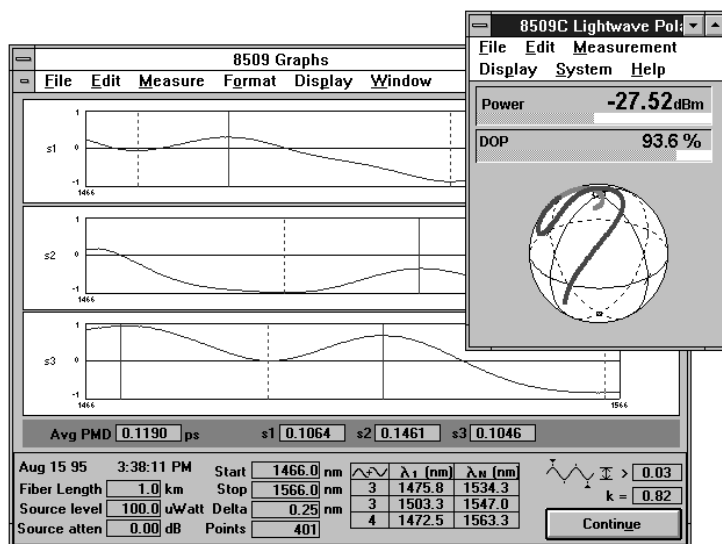

Figure 4. Shown here is the Agilent 8509C's wavelength scanning (or fixed analyzer) PMD measurement screen, after completion of a fiber PMD measurement. This PMD measurement method determines an average DGD over the measurement wavelength range. This is possible because the density of peaks and valleys in the measured curve is proportional to PMD.

Measure polarization transmission properties of components

Reduce design and manufacturing uncertainties by measuring the effects of the polarization-dependent transmission properties of optical components and systems.

Polarization Mode Dispersion

Polarization mode dispersion (PMD) effects appear as random signal fading and increased digital error rates.

Fast, accurate and repeatable, the 8509C's automatic Jones-matrix eigenanalysis technique measures PMD with a measured floor of less than 10 fs, depending on device characteristics and wavelength step size. Jones matrices of a component are measured at consecutive wavelength steps. Sets of Jones matrices are then analyzed to calculate PMD with 1 fs resolution.

A tunable lightwave source, like the Agilent 8164 tunable laser or Agilent 81680 laser, is needed for this measurement and connects with the 8509C EXTERNAL SOURCE INPUT.



Figure 5. Polarization mode dispersion measurement setup using the Agilent 8509C and Agilent 8164 or Agilent 8168 lightwave sources.

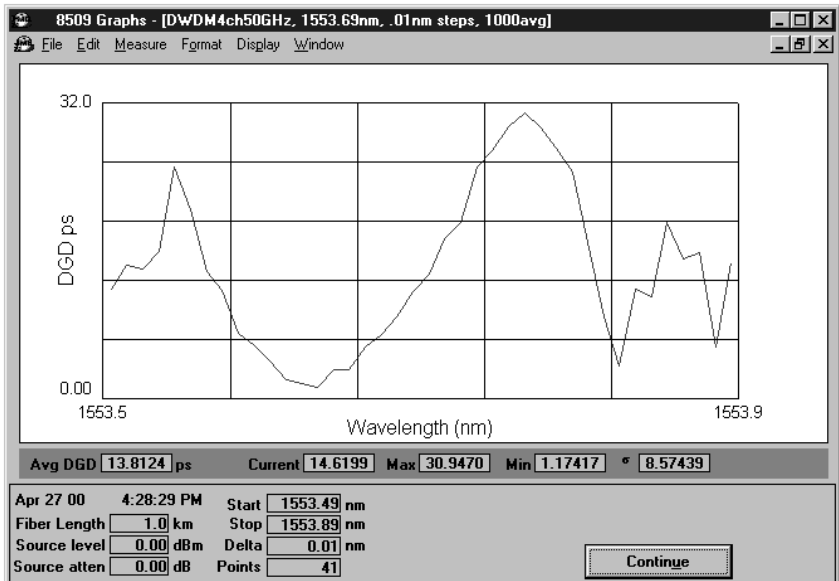

Figure 6. Narrowband PMD measurement taken with the JME method. The test device is a passive DWDM multiplexer of the AWG (array waveguide grating) technology. This measurement is taken with a 10 pm step size. The central region of the display corresponds to the passband of the device.

Measure polarization transmission properties of components

Polarization-Dependent Loss

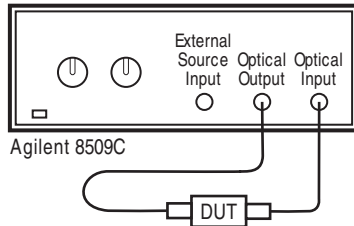

Figure 7. Polarization-dependent loss measurement setup.

The loss of optical components is usually a weak function of signal polarization. When components are connected in a system, their individual polarization-dependent losses combine randomly to affect system performance.

The 8509C uses two automated methods to measure PDL. The two methods are the all states method (power max-min method) and the Jones-matrix technique to measure the maximum, minimum and delta optical insertion loss of a component for all possible input states of polarization.

Polarization-Maintaining Fiber Launch

Whenever a single-mode fiber is moved, it changes the polarization of the transmitted lightwave. A polarization-maintaining fiber, however, can deliver a linearly polarized lightwave signal regardless of fiber movement. High extinction ratios are only possible when linearly polarized light is correctly launched onto one of the fiber's polarization axis. The 8509C can measure fiber crosstalk along the PM fiber itself to more than 50 dB with a well designed measurement setup.

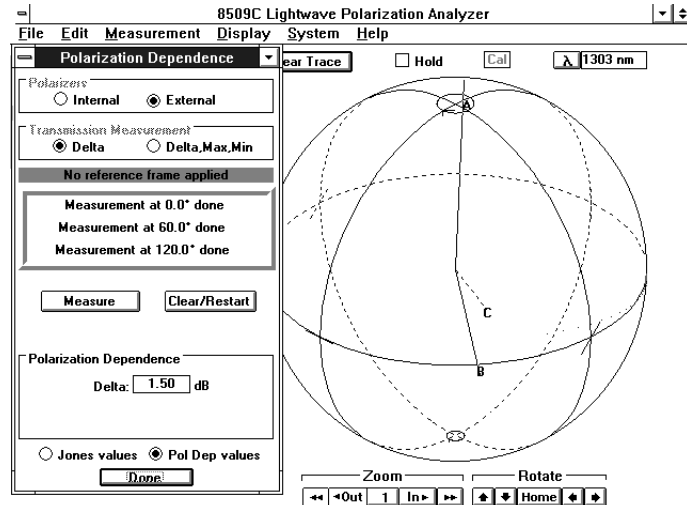

Figure 8. Polarization-dependent loss data is displayed numerically and graphically.

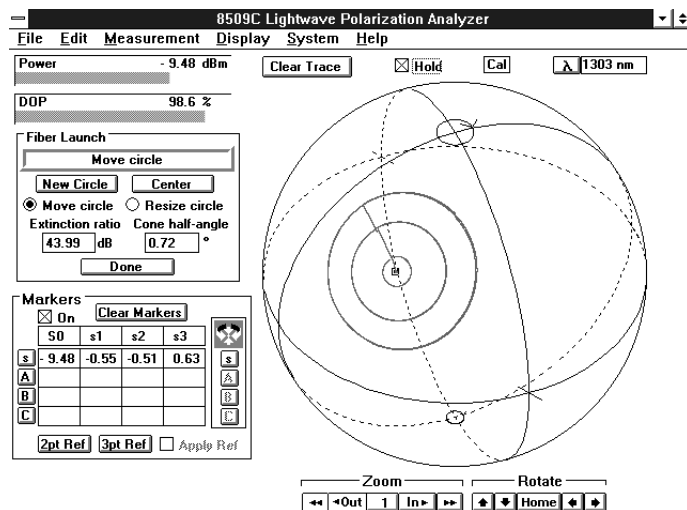

Figure 9. Typical display of polarization-maintaining fiber launch alignment process.

Data Output and Remote Operation

Measurement displays and numerical data are directly output to paper or transparency using an external printer or plotter. Graphic enhancements and additional mathematical

manipulation are possible on an external computer. This can be done via GPIB data extraction or by using a disc. External controllers remotely control the 8509C system using GPIB.

Specifications

for the Agilent 8509C
Lightwave Polarization Analyzer

Specifications describe the instrument's warranted performance over the 23 ±3°C temperature range, except where noted. All specifications apply after the instrument's temperature has stabilized (typically 1 hour after turn-on).

Characteristics provide information about non-warranted instrument performance. These are also denoted as typical.

Agilent 8509C Polarization Mode Dispersion (PMD) Specifications Using JME Technique

Calibrated wavelength operating range:

1280 nm to 1340 nm
1470 nm to 1640 nm

Maximum Measurable PMD Delay:

Depends on setup conditions and level of PMD.

Wavelength Step	1310 nm	1550 nm
0.01 nm	280 ps	400 ps
0.10 nm	28 ps	40 ps
1.0 nm	2.8 ps	4 ps
10.0 nm	0.28 ps	0.4 ps

Measurement floor is approximately <10 fs (0.01 ps) depending on setup conditions.

Resolution: 1 fs

Receiver Characteristics

Wavelength operating range: 1280 nm to 1640 nm

PMD measurement range: <0.01 ps (10 fs) to 400 ps (depends on setup conditions)

PMD measurement accuracy:^{1,2,3}

Wavelength Step	Accuracy (±)
0.01 nm	0.07 ps (70 fs)
1.0 nm	0.02 ps (20 fs)
10.0 nm	0.005 ps (5 fs)

¹ Receiver input level –20 to –40 dBm

² PMD is the average value of differential group delay across the measurement wavelength range.

³ With 81640A or 81642A Tunable Laser Source

Input power operating range: +10 dBm to –55 dBm

Input average power damage level: +16 dBm

Average power measurement linearity: ±0.06 dB

Average power measurement uncertainty: ±15%

Degree of polarization measurement:

1280 nm to 1340 nm, ±2.0%
1470 nm to 1580 nm, ±2.0%
1580 nm to 1630 nm, ±3.0%
1630 nm to 1640 nm, ±5.0%

Poincare sphere display:

1280 nm to 1340 nm, ±1.5 degrees
1470 nm to 1640 nm, ±1.5 degrees

Polarization state measurement rate:

>3500 per second

Polarization state display update rate:

>3500 per second

Return loss: –50 dB

Agilent 8509C External Source Input Port Characteristics

Wavelength operating range: 1280 nm to 1640 nm

Internal path insertion loss:

1280 nm to 1580 nm, 8.5 dB
1580 nm to 1640 nm, 10 dB

(EXTERNAL SOURCE INPUT to OPTICAL OUTPUT)

Input power operating range: +16 dBm to –49 dBm

Input average power damage level: +22 dBm

Return loss (based on OPTICAL OUTPUT connection with return loss of 30 dB or greater): 35 dB

Polarization Dependent Loss Measurement Characteristics Using the Jones-Matrix Analysis Technique

Wavelength operating range:

1280 nm to 1340 nm
1470 nm to 1640 nm

Measurement range: <3 dB

Uncertainty: ±0.1 dB

Polarization-Maintaining Fiber Launch Alignment Characteristics Using Poincare Sphere Technique

Extinction ratio range: 0 dB to 50 dB

Resolution: 0.01 dB

General Specifications

Compatible fiber: 9/125 µm

Dimensions: (H x W x D)

133.4 mm x 425.5 mm x 546.1 mm
5.25 in x 16.75 in x 21.5 in

Weight (without computer and monitor):

Net : 10.5 kg (23 lbs)

Shipping: 16.0 kg (23 lbs)

Power Requirements

(without computer and monitor):

47.5 Hz to 66 Hz

90 V to 132 V or 198 V to 264 V

100 VA

Ordering Information

The Agilent 8509C polarization analyzer consists of two rack mountable instrument boxes. The first contains the optical measurement hardware and the second provides the computer control.

The user interface runs on Microsoft® Windows 95 operating system.

The units are configured for optimum performance. Reconfiguring the hardware, adding to or tampering with the installed software can degrade or damage the instrument.

Table 1. Summary of Agilent 8509C measurement capabilities.

	State of Polarization	Degree of Polarization	Jones Matrix	Polarization-Dependent Loss	Polarization Mode Dispersion	Polarization Maintaining Fiber
Agilent 8509C	X	X	X*	X		X
Agilent 8509C + tunable source	X	X	X*	X	X	X

*The Agilent 8509C performs this measurement with external polarizers.

Agilent 8509C Lightwave Polarization Analyzer System

The polarization analyzer consists of two instrument boxes. The first contains the optical measurement hardware and the second provides the computer control.

The user interface runs on a Microsoft Windows 95® operating system. The units are configured for optimum performance. Reconfiguring the hardware, adding to or tampering with the installed software, can degrade or damage the instrument.

Source (choose one)

8509C-001 1300/1500 nm Laser Source
8509C-701 No Source

Upgrade Options

8509C-018 Controller (for upgrades)
8509C-019 Upgrade of 8509B (with current calibration)
8509C-020 Upgrade of 8509B (out of calibration)

Optical Connectors (choose one)

81000AI Diamond HMS-10 Connector
81000FI FC/PC/SPC Connector
81000KI SC Connector
81000SI DIN Connector
81000VI ST Connector

Accessories

8509C-1CM Rack Mount Kit
8509C-1CN Front Handles
8509C-1CP Rack Mount Kit with Handles

Agilent Technologies' **Test and Measurement Support, Services, and Assistance**

Agilent Technologies aims to maximize the value you receive, while minimizing your risk and problems. We strive to ensure that you get the test and measurement capabilities you paid for and obtain the support you need. Our extensive support resources and services can help you choose the right Agilent products for your applications and apply them successfully. Every instrument and system we sell has a global warranty. Support is available for at least five years beyond the production life of the product. Two concepts underlie Agilent's overall support policy: "Our Promise" and "Your Advantage."

Our Promise

Our Promise means your Agilent test and measurement equipment will meet its advertised performance and functionality. When you are choosing new equipment, we will help you with product information, including realistic performance specifications and practical recommendations from experienced test engineers. When you use Agilent equipment, we can verify that it works properly, help with product operation, and provide basic measurement assistance for the use of specified capabilities, at no extra cost upon request. Many self-help tools are available.

Your Advantage

Your Advantage means that Agilent offers a wide range of additional expert test and measurement services, which you can purchase according to your unique technical and business needs. Solve problems efficiently and gain a competitive edge by contracting with us for calibration, extra-cost upgrades, out-of-warranty repairs, and on-site education and training, as well as design, system integration, project management, and other professional engineering services. Experienced Agilent engineers and technicians worldwide can help you maximize your productivity, optimize the return on investment of your Agilent instruments and systems, and obtain dependable measurement accuracy for the life of those products.

By internet, phone, or fax, get assistance with all your test & measurement needs.

Online assistance:
www.agilent.com/comms/lightwave



Agilent Email Updates

www.agilent.com/find/emailupdates
Get the latest information on the products and applications you select.

Phone or Fax

United States:
(tel) 1 800 452 4844

Canada:
(tel) 1 877 894 4414
(fax) (905) 282 6495

China:
(tel) 800-810-0189
(fax) 1-0800-650-0121

Europe:
(tel) (31 20) 547 2323
(fax) (31 20) 547 2390

Japan:
(tel) (81) 426 56 7832
(fax) (81) 426 56 7840

Korea:
(tel) (82-2) 2004-5004
(fax) (82-2) 2004-5115

Latin America:
(tel) (305) 269 7500
(fax) (305) 269 7599

Taiwan:
(tel) 080-004-7866
(fax) (886-2) 2545-6723

Other Asia Pacific Countries:
(tel) (65) 375-8100
(fax) (65) 836-0252
Email: tm_asia@agilent.com

Product specifications and descriptions in this document subject to change without notice.

