

# Agilent 83437A Broadband Light Source

## Technical Specifications

January 2004

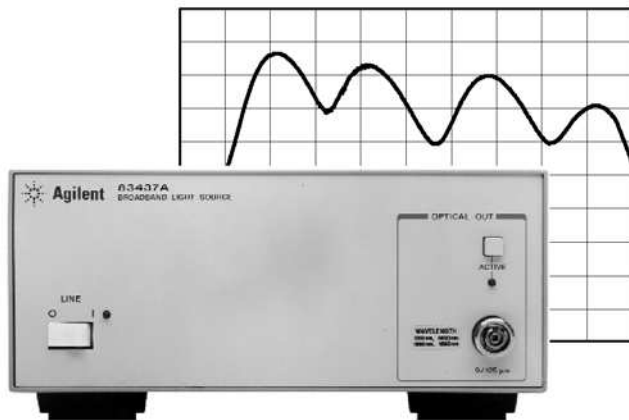
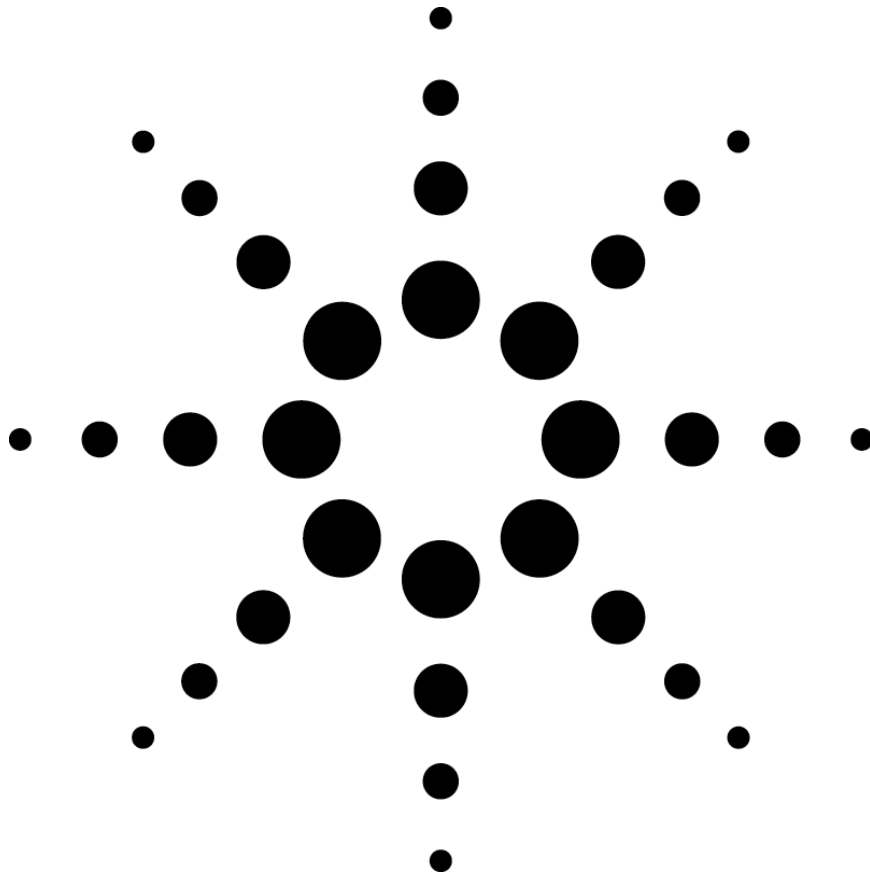

Incoherent light sources for single-mode-fiber component and subsystem characterization.

# The Technology

The Agilent Technologies 83437A Broadband Light Source (BBS) is based on Agilent Technologies' edge-emitting LED (EELED) technology. An EELED provides significantly more power density into a single-mode fiber than a regular LED and more than one hundred times that of a white light source.

Built-to-order, the 83437A can incorporate up to four EELEDs, with five available wavelengths in the 1200 to 1650 nm range. Connectors on the back panel allow you to modulate the light by applying a TTL compatible signal, or to selectively turn any of the EELEDs on (open connection) or off (shorted).

In configurations with multiple EELEDs installed, optical couplers combine the light to a single output. In order to minimize coupler losses, Agilent uses wavelength-dependent and wavelength-independent couplers depending on the ordered configuration.

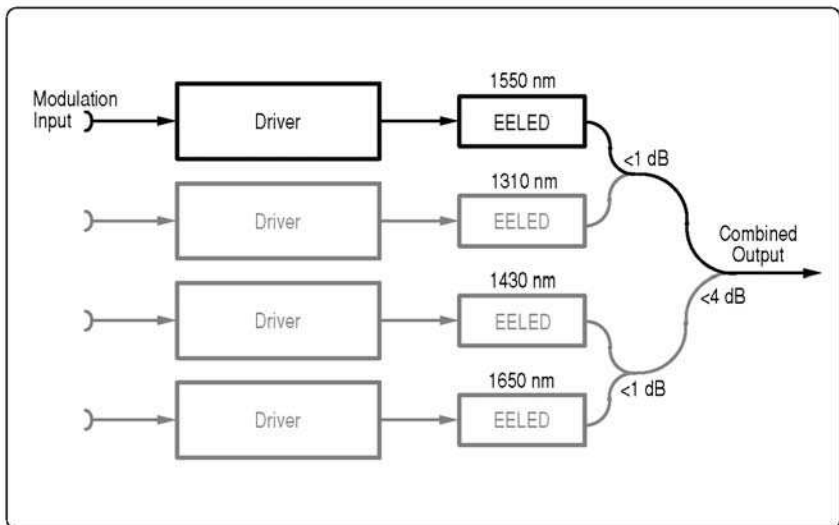

**Agilent 83437A block diagram (shown with 83437A - 003, 004, 006, and 705). Only the 1310/1550 and the 1430/1650 couplers are wavelength dependent to minimize loss. All others are standard '3 dB' couplers.**

Furthermore, an optional isolator and angled contact output connector help to increase the instrument's return loss for applications sensitive to reflections in the test setup.

# Your Benefits

## Respond to market pressure...

Manufacturers of fiberoptic components and subsystems are experiencing a dynamic and competitive market. This increases the pressure on profit margins so production costs must decrease while the devices become more complex. Per-unit test cost, as well as the initial investment in test instrumentation needs to be reduced.

**Increase your productivity and competitiveness with more accurate tests and higher throughput.**

## ...to improve the quality and the performance of your device...

Together with an optical spectrum analyzer (OSA), the Agilent Technologies 83437A will ensure that your device is accurately characterized. Reliable and repeatable measurements help to tighten margins, allowing you to sell a better product with greater profit due to a higher yield.

## ...while increasing throughput.

The significantly higher power density compared to white-light and regular LED sources allows much faster OSA sweep times. Whether you need only a simple test versus wavelength or a complex characterization including polarization and other effects, test setups using these sources significantly reduce your total measurement time.

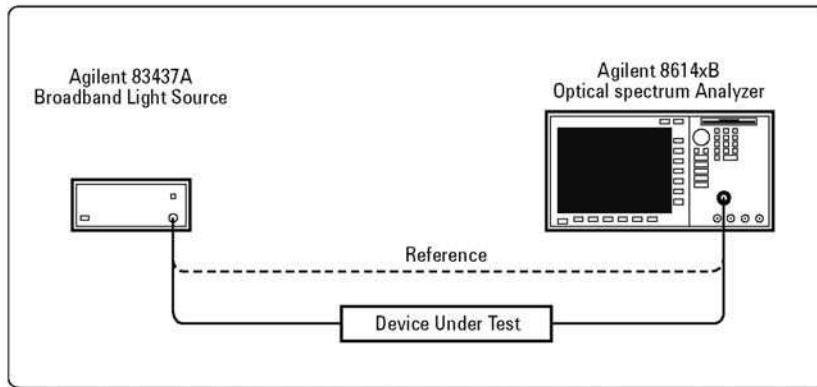

**Basic stimulus/response setup**

## ..with just the right equipment...

The JET philosophy (Just Enough Test) provides the right amount of capability necessary for key component and subsystem tests (see next pages) without excessive features or a complicated user interface.

# Stimulus/Response Applications

The performance of most passive optical components depends on wavelength, either within several nanometers or over a few hundred nanometers. If that is a critical parameter in the application of your component, then the Agilent 83437A is the perfect stimulus to probe the device under test and to characterize its wavelength dependence quickly with an optical spectrum analyzer.

Some parameters, such as isolation or crosstalk, may require a testing over a large dynamic range.

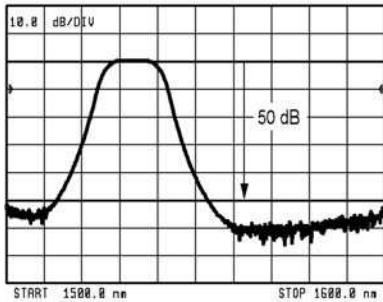

**Filter characterization with an Agilent 83437A Broadband Light Source and an Agilent Optical spectrum Analyzer (OSA).**

Because an 83437A equipped with EELEDs provides more than one hundred times the power density of a white-light source, devices can be characterized over a wide power and wavelength range. Therefore, this source allows you to measure a greater variety of components.

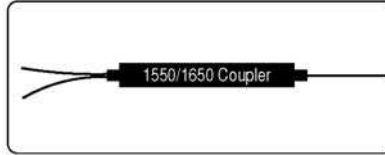

**An Agilent 83437A with multiple EELEDs allows you to characterize insertion loss, crosstalk and polarization dependence of single-mode components at standard as well as less common wavelengths.**

Furthermore, less averaging is necessary, which drastically reduces the sweep time.

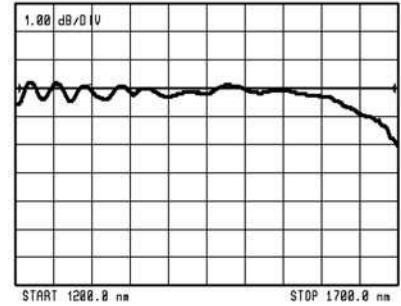

**Flatness of a 10 dB fixed attenuator**

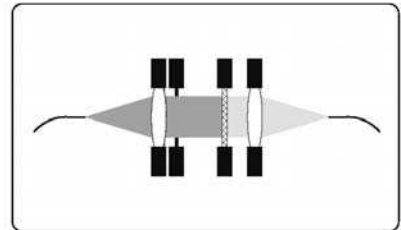

**Wavelength dependence of materials (such as infrared filter disks) measured on an optical bench. Modulating the Agilent 83437A and gating the OSA with the ADC trigger mode provides significant suppression of ambient light.**

**Measurement range of broadband sources together with an Agilent 816xB OSA at 1 nm resolution bandwidth (RBW). The measurement range increase and decrease by 10 dB for 10 nm and 0.1 nm RBW.**

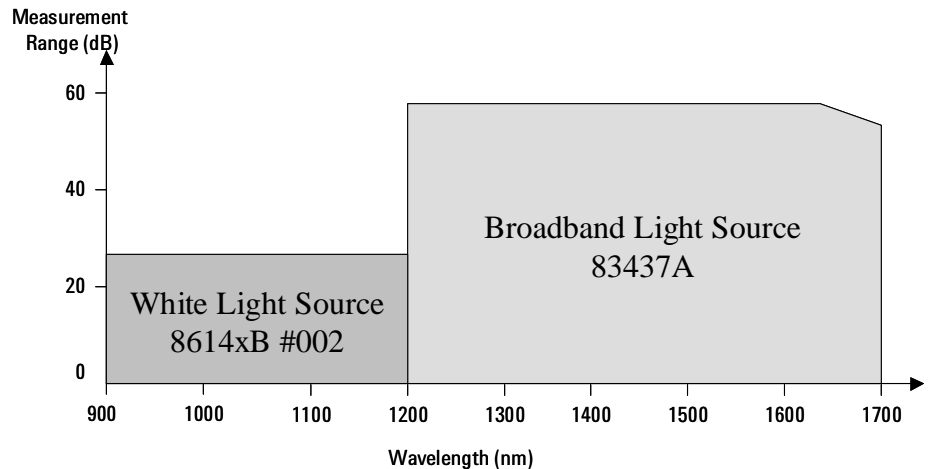

# Other Applications

## Polarization Mode Dispersion

The dispersion of optical signals in dependence on polarization can limit the bandwidth of a fiber optic system. For systems transmitting 2.5 Gb/s or more, it is essential to know the polarization mode dispersion (PMD) of the fiber to be installed. One common method is the wavelength-scanning, also called fixed-analyzer, technique.

This technique uses a broadband source, two polarizers and an optical spectrum analyzer.

In order to accurately characterize sample lengths of a few kilometers, it is necessary to probe the device under test (DUT) over a wide wavelength range. For longer cables, or for testing a previously installed link, the wavelength range may be smaller but the source power must be higher.

The 83437A covers up to 500 nm, which is necessary for characterizing devices with low but significant PMD. To make measurements in the presence of ASE (broadband background light) from optical amplifiers, the 83437A can be modulated for “lock-in” style measurements using the ADC AC trigger of the 8614xB.

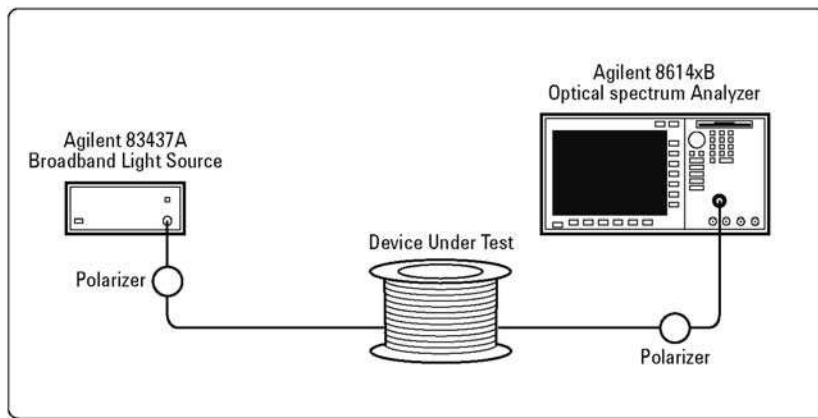

Test setup of a PMD measurement using the wavelength-scanning method.

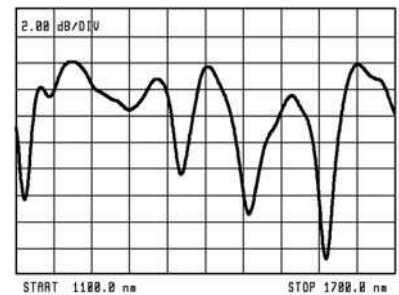

PMD measurement of a 4 km low-PMD fiber on a shipping spool.

# Agilent 83437A Specifications

## Performance Specifications and Characteristics

Peak wavelength	1200 ±30 nm	1310 ±20 nm	1430 ±30 nm	1550 ±20 nm <sup>1</sup>	1650 ±30 nm
3 dB width <sup>2</sup>	45 nm	47 nm	50 nm	52 nm	55 nm
Total power <sup>3,7</sup>	> -17 dBm 20 μW	> -13 dBm 50 μW	> -13 dBm 50 μW	> -13 dBm 50 μW	> -17 dBm 20 μW
Peak density <sup>2,3</sup>	> -37 dBm [1 nm] >200 nW/nm	> -33 dBm [1 nm] >500 nW/nm	> -33 dBm [1 nm] >500 nW/nm	> -33 dBm [1 nm] >500 nW/nm	> -37 dBm [1 nm] >500 nW/nm
Compatible filter	9/125 μm, single mode				
Output return loss <sup>2</sup>	> 25 dB (50 dB <sup>5</sup> )				
Power stability <sup>4</sup>	(1310/1430/1550) < ±0.02 dB (15 min), < ±0.05 dB (6 hr) (1200/1650) < ±0.03 dB (15 min), < ±0.05 dB (6 hr)				
Modulation <sup>2</sup>	Digital (TTL compatible input), 100% on-off, DC to 100 kHz				
LED Safety	IEC 825-1 Class 1				
Weight	5.5 kg (12 lbs)				
Dimensions <sup>6</sup>	102 mm H x 213mm W x 450 mm D (4.02 in H x 8.39 in W x 17.72 in D)				
Power	90 to 132 V or 198 to 264 V AC, 47 to 63 Hz, 50 W				
Operating Temperature	0°C to +45°C				
Storage Temperature	-40°C to +45°C				

<sup>1</sup> Default Configuration.

<sup>2</sup> Characteristic value (not warranted).

<sup>3</sup> Configurations with multiple EELEDs have less power. Typical losses are 3.5 dB *per coupler*, except the 1310/1550 nm and the 1430/1650 nm coupler that have less than 1 dB loss (see spectra for typical configurations; see page 2 for a block diagram).

<sup>4</sup> Ambient temperature change <±.1°C, measured with power meter having >30 dB return loss and after 1 hour warm-up time.

<sup>5</sup> Measured at 1550 nm with isolator (83437A-001) and FC/APC connector (83437A-022).

<sup>6</sup> System II chassis (half module, 3.5 in height, 1.75 in hole spacing).

<sup>7</sup> Measured with an InGaAs power sensor.

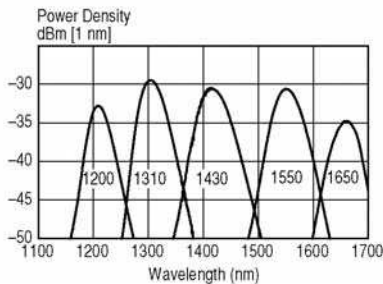

**Characteristic spectra in single EELED configurations**

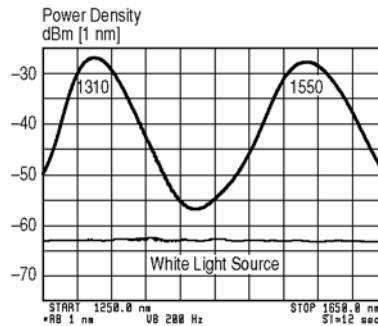

**Characteristic spectrum in the 1310/1550 nm dual EELED configuration (Agilent 83437A with options 003 and 705)**

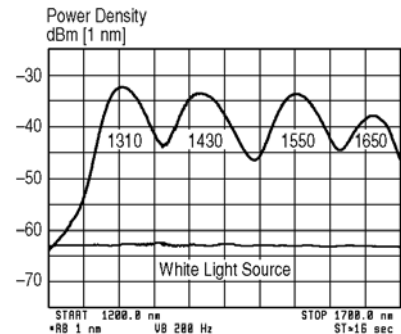

**Characteristic spectrum when four EELEDs are installed (Agilent 83437A with options 003, 004, 006, and 705)**

## Ordering Information

### 83437A Broadband (EELED) Light Source

#### Source Options

83437A - 002	1200 nm EELED
83437A - 003	1310 nm EELED
83437A - 004	1430 nm EELED
83437A - 705	1550 nm EELED (default configuration)
83437A - 006	1650 nm EELED

No more than four EELEDs can be installed at a time (see block diagram on page 2). (Option 705, 1550 nm EELED only).

#### Connector Options

83437A - 021	Straight (non-angled) Contact Interface-PC (default)
83437A - 022	Angled Contact Interface - APC
81000FI	FC Connector (default)
81000KI	SC Connector
81000NI	FC/APC Connector
81000SI	DIN Connector
81000VI	ST Connector

#### Accessories

83437A - UK6	Commercial calibration certificate with test data
83437A - 1CM	Rack mount kit
83437A - 1CN	Front handles
83437A - 1CP	Rack mount kit with handles

This page intentionally left blank

## Agilent Technologies' Test and Measurement Support, Services, and Assistance

Agilent Technologies aims to maximize the value you receive, while minimizing your risk and problems. We strive to ensure that you get the test and measurement capabilities you paid for and obtain the support you need. Our extensive support resources and services can help you choose the right Agilent products for your applications and apply them successfully. Every instrument and system we sell has a global warranty. Support is available for at least five years beyond the production life of the product. Two concepts underlie Agilent's overall support policy: "Our Promise" and "Your Advantage."

### Our Promise

Our Promise means your Agilent test and measurement equipment will meet its advertised performance and functionality. When you are choosing new equipment, we will help you with product information, including realistic performance specifications and practical recommendations from experienced test engineers. When you use Agilent equipment, we can verify that it works properly, help with product operation, and provide basic measurement assistance for the use of specified capabilities, at no extra cost upon request. Many self-help tools are available.

### Your Advantage

Your Advantage means that Agilent offers a wide range of additional expert test and measurement services, which you can purchase according to your unique technical and business needs. Solve problems efficiently and gain a competitive edge by contracting with us for calibration, extra-cost upgrades, out-of-warranty repairs, and on-site education and training, as well as design, system integration, project management, and other professional engineering services. Experienced Agilent engineers and technicians worldwide can help you maximize your productivity, optimize the return on investment of your Agilent instruments and systems, and obtain dependable measurement accuracy for the life of those products.

**By internet, phone, or fax, get assistance with all your test & measurement needs**

#### Online assistance:

[www.agilent.com/comms/optical](http://www.agilent.com/comms/optical)

#### For related literature, please visit:

[www.agilent.com/comms/octsources](http://www.agilent.com/comms/octsources)

#### Phone or Fax

United States:  
(tel) 1 800 452 4844

#### Canada:

(tel) 1 877 894 4414  
(fax) (905) 282-4120

#### Europe:

(tel) (31 20) 547 2323  
(fax) (31 20) 547 2390

#### Japan:

(tel) (81) 426 56 7832  
(fax) (81) 426 56 7840

#### Latin America:

(tel) (305) 269 7500  
(fax) (305) 269 7599

#### Australia:

(tel) 1 800 629 485  
(fax) (61 3) 9210 5947

#### New Zealand:

(tel) 0 800 738 378  
(fax) 64 4 495 8950

#### Asia Pacific:

(tel) (852) 3197 7777  
(fax) (852) 2506 9284

Product specifications and descriptions in this document subject to change without notice.

Copyright © 1996 - 2004 Agilent Technologies

January 31, 2004

5965-3252E



**Agilent Technologies**