

Agilent 83446A Lightwave Clock/Data Receiver

Product Overview

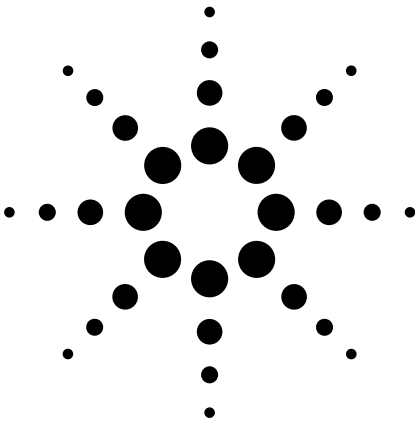

High gain optical receiver for recovering clock and data directly from optical fiber

- **OC-48/STM-16 data rate (2.48832 Gb/sec)**
- **Operates over full range of power levels specified in SONET/SDH standards**
- **1310/1550 nm operation**
- **Auxiliary input recovers clock and data from 2.48832 Gb/sec electrical signals**

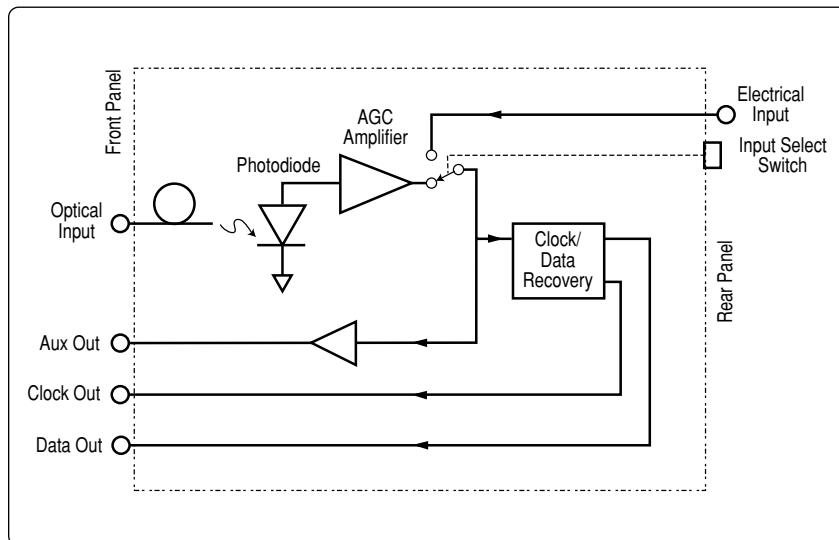

Agilent's 83446A Lightwave Clock/Data Receiver is designed to extract clock and data information from digitally modulated lightwave signals. The 83446A is for use with OC-48/STM-16 (2.48832 Gb/sec) signals. It incorporates a high-gain avalanche photo-diode (APD), gain-controlled amplifier, and clock/data recovery hybrid to deliver clean, error-free outputs from optical signals with powers as low as -27 dBm at either 1310 or 1550 nm wavelengths. The Agilent 83446A is designed especially for use with high speed bit-error-ratio testers (BERTs) such as the Agilent 86130A. By connecting the 83446A clock and data outputs to the corresponding inputs on the BERT's error detector, bit-error-ratio analysis can be performed directly on optical signals, making it easy to do system acceptance and BER floor analysis.



Agilent Technologies

The high sensitivity of the Agilent 83446A assures accurate results over the full range of optical powers specified in SONET/SDH standards such as ITU G.957 and Bellcore TA-NWT-000253. It can also be useful for optical eye diagram analysis on sampling oscilloscopes. In situations where no separate clock signal is available, the clock output of the 83446A can be used to trigger the oscilloscope. Unlike schemes that use the data pattern as the trigger source, triggering from a recovered clock assures that the eye diagram is an accurate representation of all possible bit combinations on the incoming data stream.

For analog monitoring of unconditioned data, the Agilent 83446A provides an auxiliary electrical output. This high-gain AGC controlled output is useful for general diagnostic analysis of the incoming waveform. (Because its frequency response does not meet the stringent requirements for eye mask compliance testing defined in SONET/SDH standards, mask tests should be done with an appropriate reference receiver.

Another feature of the 83446A is a rear-panel input for recovering clock and data from an electrical waveform. A rear panel switch selects between either the front optical input or the rear electrical input. (The electrical input bypasses the internal high-gain amplifier, so external amplification must be used when operating on low power signals to achieve a level sufficient for proper operation.) The Agilent 83446A uses a 50 μm fiber core diameter which is compatible with either single-mode or multi-mode fibers. The optical input incorporates a universal adapter for use with any of the connector interfaces in the Agilent 81000 series. The standard instrument includes an FC/PC connector interface. Option 010 deletes the FC/PC connector. Interfaces for other optical connector types must be ordered separately.

Agilent 83446A

Laser Transmitter Optimization

The Agilent 83446A, in conjunction with an Agilent 86130A Error Performance Analyzer and Agilent 8156A High-performance Optical Attenuator, can help determine the optimum bias setting for laser transmitters. The optimum bias is found when the improvement in BER, due to higher extinction ratio, is balanced by degradation due to increased nonlinear waveform distortion effects. BER floors are easily identified by monitoring the error rate as the input power level to the 83446A is increased. The Agilent 83446A operates error-free at input powers above -27 dBm, so any residual errors at higher input powers can be associated with the transmitter under test.

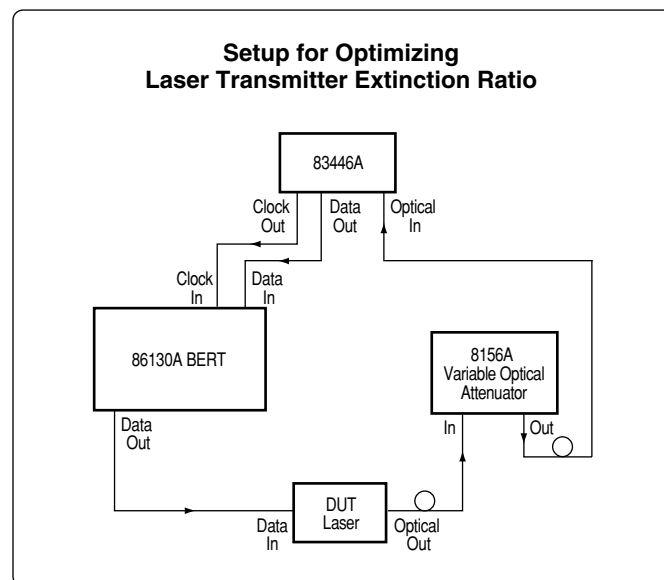

Dispersion Power Penalty Testing

Signal degradation due to fiber dispersion can have a major impact on the maximum distance over which optical data can reliably be sent. This is a particular concern when 1550 nm lasers are used with fiber optimized for transmission at 1300 nm. To evaluate the dispersion power penalty of a system, the 83446A can be used in conjunction with the Agilent 86130A Error Performance Analyzer. By testing the error performance of the laser when used with a long length of the intended fiber, the power penalty due to dispersion can easily be evaluated.

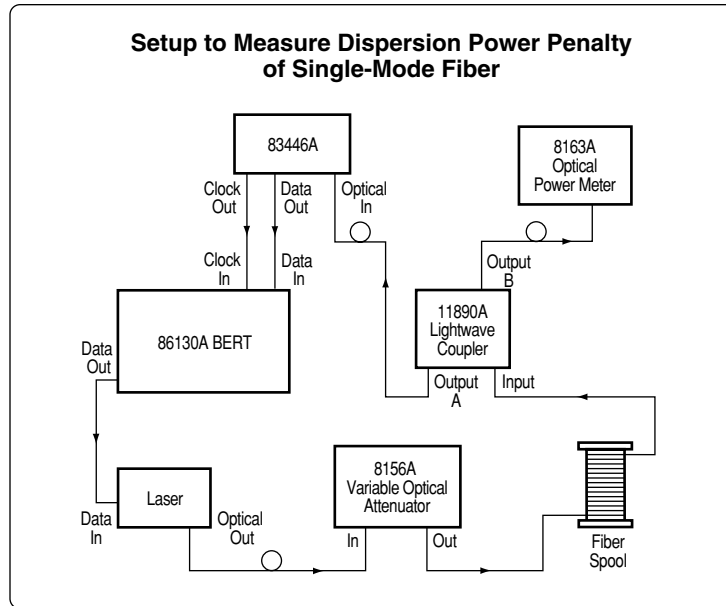

Waveform Test: Example of Measuring Eye Diagram With Recovered Clock Signal As a Trigger

Eye diagrams are important tools for characterizing the waveform performance of a laser source. An eye diagram is generated on an oscilloscope by observing the data output from the laser while triggering the oscilloscope from a separate signal at the clock frequency.

In many cases a separate clock signal is not readily accessible. To generate a valid eye diagram, clock must be recovered from the data waveform and used to trigger the oscilloscope. The Agilent 83446A is ideal for generating this recovered clock. In addition, the waveform from the Agilent 83446A's AUXILIARY OUT port is often adequate as the data input to generate the eye diagram.

Certain industry standards such as SONET and Fibre Channel require that the eye diagram be measured through a reference receiver having a carefully-controlled frequency response. In this case, the Agilent 83446A can be used to recover the clock and a separate reference receiver used to display the eye diagram.

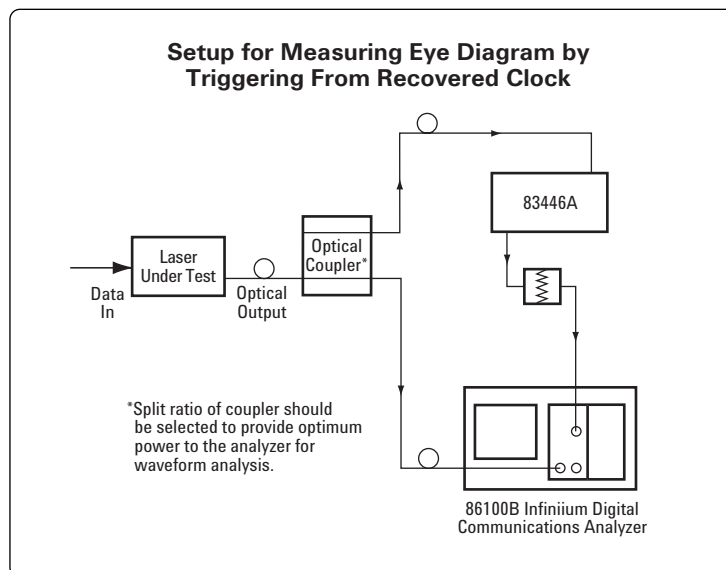

Performance Specifications and Characteristics

Specifications describe the instrument's warranted performance over the 0°C to 55°C temperature range, except where noted. Characteristics (italicized) provide information about non-warranted instrument performance in the form of nominal values. All amplitude specifications are in optical power units unless noted by an asterisk (*).

Specifications/Characteristics

Operating Data Rate	2.48832 GHz \pm 0.5%, NRZ coding
Sensitivity ^{1, 2, 4, 5}	-27 dBm min
Wavelength Range	<i>1200 to 1600 nm</i>
Data Out Amplitude ³	0.5 v pk-pk
Clock Out Amplitude	0.5 v pk-pk
Max Operating Input Power ^{1, 4}	-9 dBm min Input
Optical Return Loss ⁷	27 dB
Output Electrical Return Loss	<i>12 dB* @ 1 GHz 9 dB* @ 2 GHz 6 dB* @ 2.5 GHz</i>
Max Safe Optical Input Power	+10 dBm
RMS Jitter	
On Clock/Data Outputs ⁶	<i>5 degrees</i>
Auxiliary Out Bandwidth	<i>0.1 to 1500 MHz</i>
Electrical Clock Recovery	
Input Sensitivity	<i>200 mv pk-pk</i>
Max Safe Electrical Clock	
Recovery Input	<i>2 v pk-pk</i>
Auxiliary Output (Optical Input)	<i>0.5 v pk-pk for >-24 dBm input (AGC Stabilized) 0.25 v pk-pk for >-27 dBm input</i>
Auxiliary Output (Electrical Input)	<i><6 dB* down from input signal level</i>

General/Environmental

Temperature Range	Operational: 0° to +55°C Storage: -40° to +70°C
EMI	Conducted and radiated emissions are in compliance with the requirements of CISPR Publication 11 and EN 55011 Group 1, Class A
Power Requirements	100, 120, 220, or 240 volts (\pm 10%), 47 to 63 Hz
Power consumption	<75VA
Weight	3.36 kg (7.5 lb)
Dimensions	102 mm (4.02 in.) height 213 mm (8.39 in.) width 368 mm (14.49 in.) length

1. Better than 1E-10 bit error ratio with 2²³-1 PRBS pattern, 50% mark density.

2. Sensitivity may be degraded if signals are applied simultaneously to both front optical input and rear electrical input.

3. Non-inverting output.

4. Source extinction ratio \geq 8.2 dB at eye center.

5. Sensitivity specification applies over temperature range of 25 \pm 5°C

6. Clock edges nominally aligned with data transitions to \pm 0.25 unit interval.

7. Measured using single mode fiber from source.

Ordering Information

Agilent 83446A Lightwave Clock/Data Receiver

Optical connectors (choose one)

Option 83446A-011 No optical connector

Option 83446A-012 FC/PC connector interface

Related Accessories

Agilent 86100B Infiniium Digital Communications Analyzer

Agilent 10086A ECL Terminator

Agilent 83440B/C/D Lightwave Converters

Agilent 86130A BitAlyzer® Error Performance Analyzer

Agilent 8156A Optical Attenuator

Agilent 11980A Lightwave Directional Coupler



Agilent Email Updates

www.agilent.com/find/emailupdates

Get the latest information on the products and applications you select.

By internet, phone, or fax, get assistance with all your test & measurement needs.

Online assistance:

www.agilent.com/comms/lightwave

Phone or Fax

United States:

(tel) 1 800 452 4844

Canada:

(tel) 1 877 894 4414

(fax) (905) 282 6495

China:

(tel) 800-810-0189

(fax) 1-0800-650-0121

Europe:

(tel) (31 20) 547 2323

(fax) (31 20) 547 2390

Japan:

(tel) (81) 426 56 7832

(fax) (81) 426 56 7840

Korea:

(tel) (82-2) 2004-5004

(fax) (82-2) 2004-5115

Latin America:

(tel) (305) 269 7500

(fax) (305) 269 7599

Taiwan:

(tel) 080-004-7866

(fax) (886-2) 2545-6723

Other Asia Pacific Countries:

(tel) (65) 375-8100

(fax) (65) 836-0252

Email: tm_asia@agilent.com

Product specifications and descriptions in this document subject to change without notice.

© 1994, 2000, 2002 Agilent Technologies, Inc.
Printed in USA June 12, 2002
5964-1682E



Agilent Technologies