

Agilent 87204/87206A, B, C Multiport Coaxial Switches dc to 4 GHz, dc to 20 GHz, dc to 26.5 GHz

Product Overview

High performance multiport switches for microwave and RF instrumentation and systems

- SP4T and SP6T configuration
- Exceptional repeatability for more than 5 million cycles
- Excellent isolation, typically >90 dB at 26.5 GHz
- Magnetic latching
- Terminated ports
- Self-interrupting drive circuit
- Fully compatible with Agilent 87130A/70611A switch drivers

Modern automated test systems demand higher accuracy and performance than ever before. The Agilent Technologies 87204A/B/C and 87206A/B/C multiport switches offer excellent insertion loss repeatability and high isolation necessary to achieve superior test system performance. Long life, repeatability, and reliability reduce the cost of ownership by reducing calibration cycles and increasing test system uptime. These features are vital to ATS measurement system integrity over time.

Description

The 87204A/B/C SP4T and 87206A/B/C SP6T terminated multiport switches provide the life and reliability required for automated test and measurement, signal monitoring, and routing applications. Innovative design and careful process control create switches which meet the

requirements for highly repeatable switching elements in test instruments and switching interfaces. The switches are designed to operate for more than 10 million cycles. The exceptional 0.03 dB insertion loss repeatability is warranted for 5 million cycles at 25°C. This reduces sources of random errors in the measurement path and

improves measurement uncertainty. Switch life is a critical consideration in production test systems, satellite and antenna monitoring systems, and test instrumentation. The longevity of these switches increases system uptime, and lowers the cost of ownership by reducing calibration cycles and switch maintenance.



Agilent Technologies

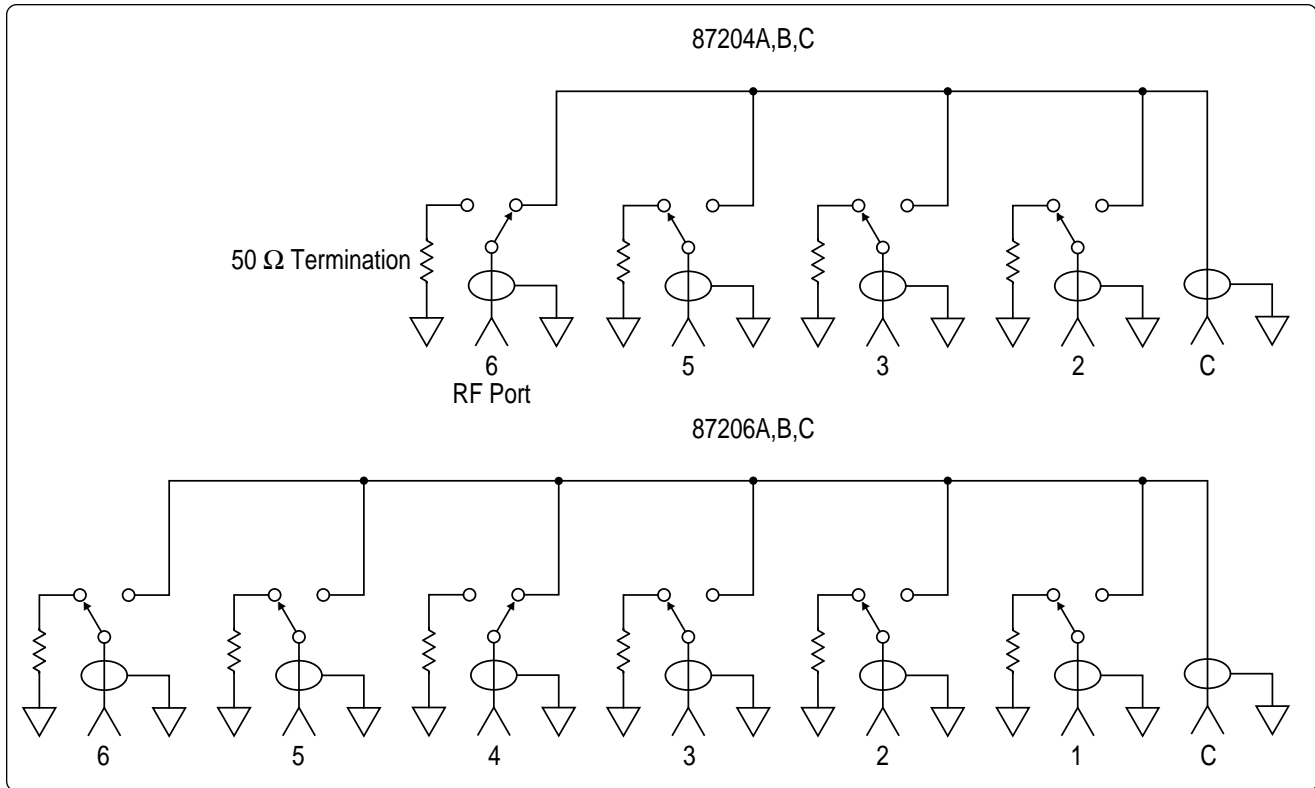

Figure 1. Agilent 87204A/B/C and 87206A/B/C simplified schematics

Operating to 4 GHz (A models), 20 GHz (B models), and 26.5 GHz (C models), these switches exhibit exceptional isolation performance required to maintain measurement integrity. Isolation between ports is typically >100 dB to 12 GHz and >90 dB to 26.5 GHz. This reduces the influence of signals from other channels, sustains the integrity of the measured signal, and reduces system measurement uncertainties. These switches also minimize measurement uncertainty with low insertion loss and reflection, which makes them ideal elements in large, multi-tiered switching systems.

Both the 87204A/B/C and 87206A/B/C are designed to fall within most popular industry footprints. The 2¼ inch square flange provides mounting holes, while the rest of the 2½ inch long by 2¼ inch diameter body will easily fit into most systems. Ribbon cable or optional solder terminal connections accommodate the need for secure and efficient control cable attachment.

Option 100 provides solder terminal connections in place of the 16-pin ribbon drive cable. Option 100 does not incorporate the “open all paths” feature.

Each port is individually controlled by its corresponding “close” and “open” control lines. All open paths are terminated with 50-ohm loads. A port is closed or open when its corresponding “close” or “open” pin is connected to ground. At this point, the current to the solenoids is shut off by the optoelectronic interrupts. This improves reliability and extends the life of the switch by eliminating dc circuit contact failures characteristic of conventional electromechanical switches. This configuration allows compatibility with the Agilent 87130A and Agilent 70611A switch drivers’ position monitoring and reporting feature.

Applications

Multiport switches find use in a large number of applications, increasing system flexibility and simplifying system design.

Simple signal routing

The simplest signal routing scheme takes the form of single input to multiple outputs. These matrixes are often used at the input of an analyzer to test several two-port devices sequentially or to test multiport devices. In surveillance applications, a multiport switch can be used to select the optimum antenna for intercepting a signal.

Two methods can be used to accomplish the single input to multiple output arrangement. Traditionally, where isolation greater than 60 dB was required, a tree matrix composed of SPDT switches was used. While this provided high isolation, it was at the cost of more switches (Figure 2). The 87204 and 87206 switches have port-to-port isolations typically greater than 90 dB at 26.5 GHz, eliminating the need for a tree matrix to achieve high isolation (Figure 3). In addition to the reduced part count, the path lengths are shorter, so insertion loss is less. Also, paths are of equal length, so phase shift is constant.

Full access switching

Full access switching systems have the flexibility to route multiple input signals to multiple outputs simultaneously. Full access switching matrixes

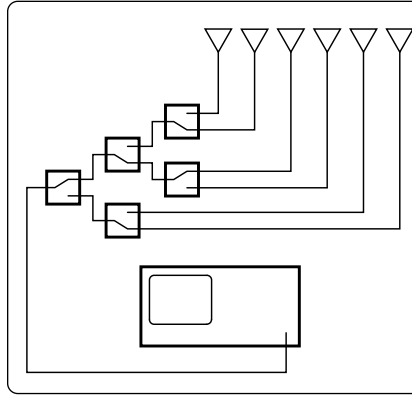

Figure 2. Tree matrix

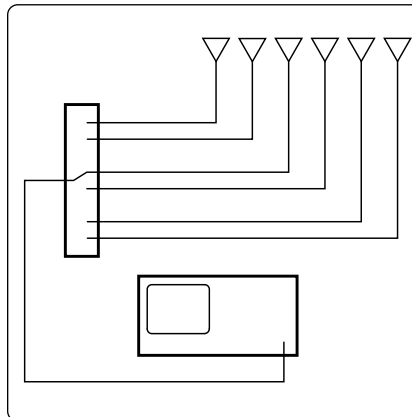

Figure 3. Multiport matrix

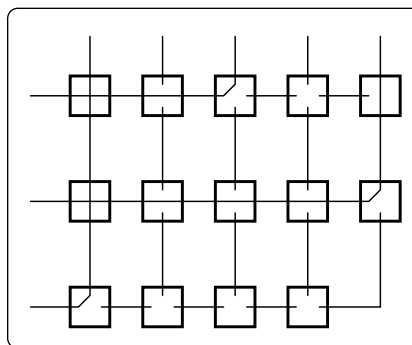

Figure 4. Cross-point matrix

are used in test systems to provide flexible routing of signals between different devices under test and stimulus and analysis instrumentation. Cross-point matrixes, using single-pole double-throw and cross-point switches, have traditionally been used to maintain high channel-to-channel isolation (Figure 4). As with the tree matrixes, this is at the cost of hardware and performance. Full access switching can also be achieved using multiport switches (Figure 5).

The advantage of the multiport matrix over the cross-point matrix is lower insertion loss and improved SWR performance due to consistent path length and fewer switches and connecting cables.

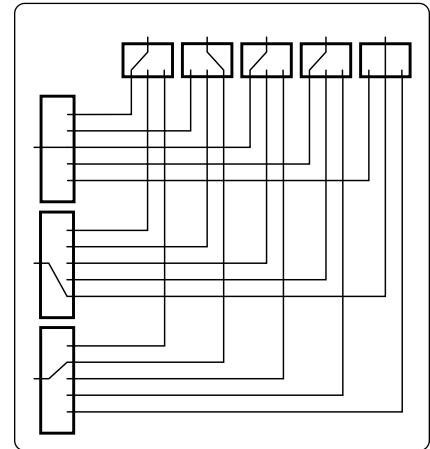

Figure 5. Full access matrix

Dedicated switching

There are a number of applications where switching may be used, not for flexibility, but to accomplish a particular function within an instrument. For example, filter banks for reducing harmonics in the output of sources or at the input of analyzers can use multipoint switches in series to select the right filter for the band of interest.

Driving the switch

Each RF path is controlled independently. An “open” or “closed” signal must be sent to achieve the desired state for each section of the switch (see Figure 8 on page 9 for drive connection diagrams).

- Connect pin 1 to supply (+20 Vdc to +32 Vdc).
- Connect pin 15 to ground (see Note 1).
- “Open” desired RF path by applying ground to the corresponding “open” pin; for example, ground pin 4 to open RF path 1 (see Notes 2, 3).
- Close desired RF path by applying ground to the corresponding RF path “close” pin; for example, ground pin 3 to close RF path 1 (see Notes 2, 3).
- To open all RF paths, ensure that RF path “close” pins are disconnected from ground. Then, connect pin 16 to ground. Note: This feature is not available with Option 100.

Notes:

1. Pin 15 must always be connected to ground to enable the electronic position-indicating circuitry and drive logic circuitry.

CAUTION: IF PIN 15 IS NOT CONNECTED TO POWER SUPPLY GROUND, CATASTROPHIC FAILURE WILL OCCUR.

2. After the RF path is switched and latched, the drive current is automatically interrupted by the electronic position-sensing circuitry. Pulsed control is not necessary, but if implemented, the pulse width must be 15 ms minimum to ensure that the switch is fully latched.
3. Make-before-break switching can be accomplished by closing the new RF path before opening the old RF path. This will simultaneously engage the old RF path and the new RF path. Once the new RF path is engaged (15 ms), open the closed path by grounding the RF path open select pin. Break-before-make is accomplished by opening the old RF path before closing the new RF path.

For larger switching systems, where many switches will be used to provide complex signal routing, a switch driver such as the Agilent 87130A or 70611A is recommended. The 87130A rack-and-stack switch driver and the MMS-based 70611A are convenient, flexible GPIB or MSIB switch controllers, providing driver circuitry, position monitoring, and reporting, and firmware that makes it easy to integrate switch components into a switching system.

The 87130A must be controlled by either a PC or workstation-based GPIB controller and appropriate software (for example, Agilent ITG or VEE).¹

The 70611A gives manual control via the MMS user interface or can also be controlled via a GPIB-equipped PC or workstation.

Accessory cables and adapters make it easy to connect an 87204/87206 to the 87130A (see Ordering Information). In addition, the built-in firmware makes it possible to define frequently used switch paths. With the path command, macros can be designed which open and close the right solenoids to select the desired switch port; this path may then be named.

A programmable wake-up condition makes it possible to ensure that the matrix or switching system starts up in a predetermined state.

For smaller switching needs, the Agilent 11713A 10-channel attenuator/switch controller provides simple GPIB control for one 87206 and one 87204 or two 87204 switches with Option 100. Connecting cables can be ordered that make it easy to connect the switches to the 11713A (see Ordering Information).

1. ITG: Instrument Test Generator,
VEE: Visual Engineering Environment

Specifications

Specifications describe the instrument's warranted performance. **Supplemental** and **typical characteristics** are intended to provide information useful in applying the instrument by giving typical, but not warranted performance parameters.

Maximum power rating: 1 watt average into 50 Ω internal loads
Switching: 1 W CW
Non-switching: 50 W Pk (not to exceed 1 watt average)
Life: 5,000,000 cycles minimum
Switching speed: 15 ms maximum

Environmental specifications

Operating temperature: -25 to 75°C
Storage temperature: -55 to 85°C
Temperature cycling: -55 to 85°C, 10 cycles per MIL-STD-202F, Method 107D, Condition A (modified)
Vibration:
Operating: 7 g: 5 to 2000 Hz at 0.25 in p-p
Survival: 20 g: 20 to 2000 Hz at 0.06 in p-p, 4 min/cycle, 4 cycles/axis
Random: 2.41 g (rms) 10 min/axis

Shock: Half-sine: 500 g at 0.5 ms, 3 drops/direction, 18 total
Operating: 50 g at 6 ms, 6 directions
Moisture resistance: 65°C, 95% RH, 10 days per MIL-STD-202F, Method 106E
Altitude storage: 50,000 feet (15,240 meters per MIL-STD-202F, Method 105C, Condition B)
RFI: Per MIL-STD-461C, RE02, Part 4
Magnetic field: <5 gauss 1/4 inch from surface

Physical specifications

Dimensions: Per Figure 9 on page 10
Weight: 229 gm (0.50 lb)

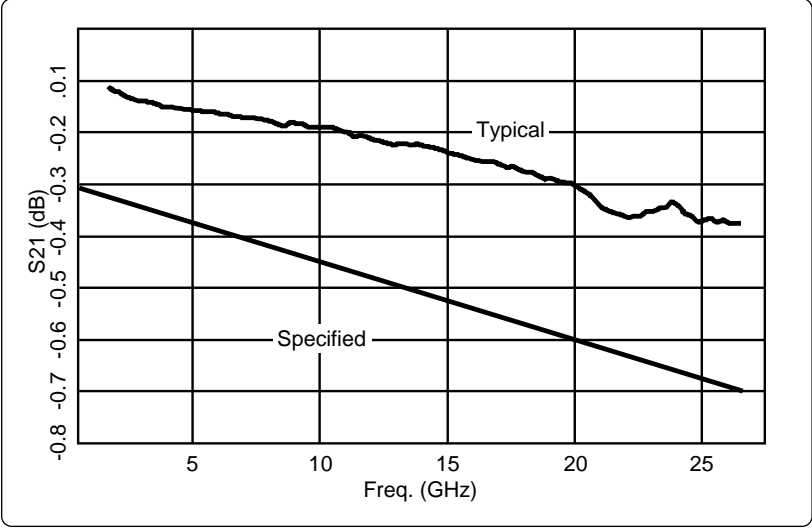

Figure 6. Insertion loss

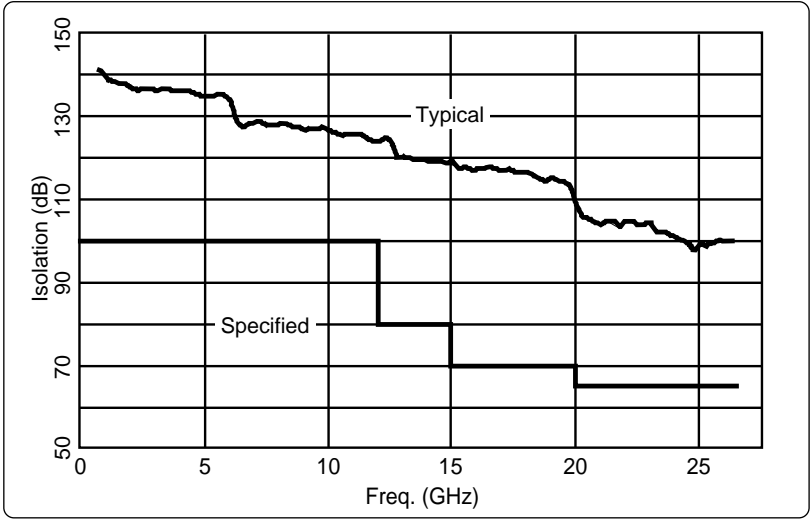

Figure 7. Isolation

Switch drive specifications

Parameter	Test conditions	Min	Nom	Max	Units
Supply Voltage, Vcc					
STD, Option 100		20	24	32	V
Supply Current, Icc					
STD, Option 100	Switching; Pulse Width $\geq 15\text{ms}$ Vcc=24Vdc		200 ¹		
Supply Current, Icc (quiescent)		25		50	mA

1. Closing one RF path requires 200 mA. Add 200 mA for each additional RF path closed or open.

	87204A 87206A	87204B 87206B	87204C 87206C
Frequency range	dc to 4 GHz	dc to 20 GHz	dc to 26.5 GHz
Insertion loss (see Fig. 6)	0.3 dB + 0.015 x frequency (GHz)	0.3 dB + 0.015 x frequency (GHz)	0.3 dB + 0.015 x frequency (GHz)
Isolation (see Fig. 7)	100 dB minimum	100 dB minimum 12 GHz 80 dB minimum 12 to 15 GHz 70 dB minimum 15 to 20 GHz	100 dB minimum 12 GHz 80 dB minimum 12 to 15 GHz 70 dB minimum 15 to 20 GHz 65 dB minimum 20 to 26.5 GHz
SWR	1.2:1 maximum	1.2 maximum dc to 4 GHz 1.35 maximum 4 to 12.4 GHz 1.45 maximum 12.4 to 18 GHz 1.7 maximum 18 to 20 GHz	1.2 maximum dc to 4 GHz 1.35 maximum 4 to 12.4 GHz 1.45 maximum 12.4 to 18 GHz 1.7 maximum 18 to 26.5 GHz
Repeatability (Up to 5 million cycles measured at 25°C)	0.03 dB maximum	0.03 dB maximum	0.03 dB maximum
Connectors	SMA (f)	SMA (f)	SMA (f)

Supplemental characteristic

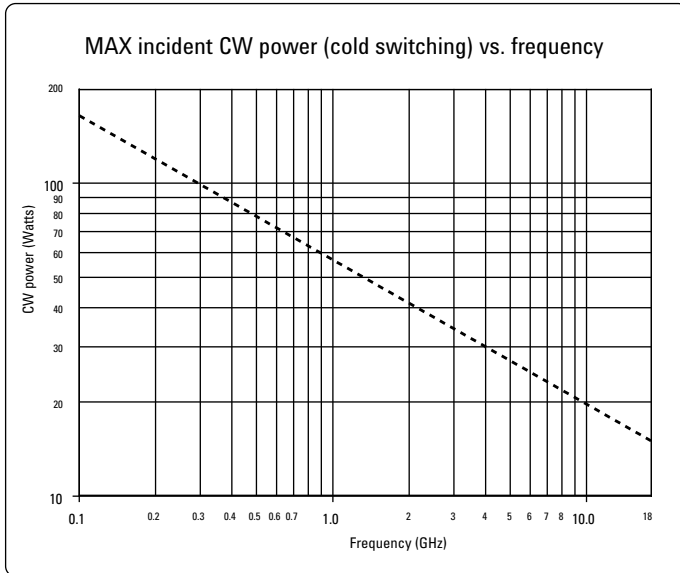

Reference conditions:

- Cold switching only (NO Hot switching)
- Ambient temperature of 75°C or less
- Sea level (0.88 derating @ 15,000ft.)
- Load VSWR < 1.2 (see graph for derating above 1.2 VSWR)

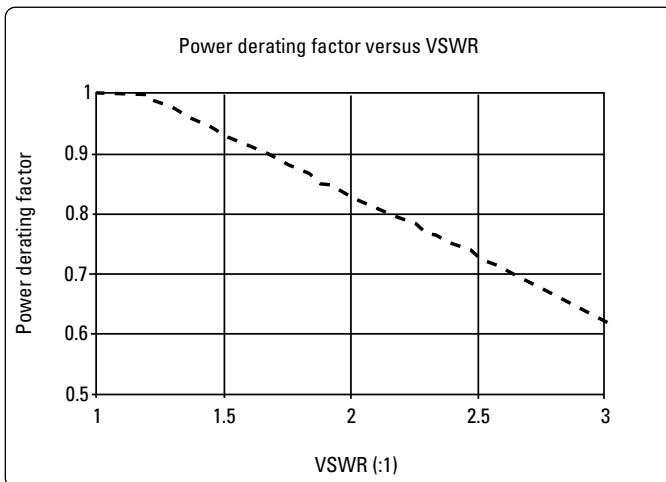

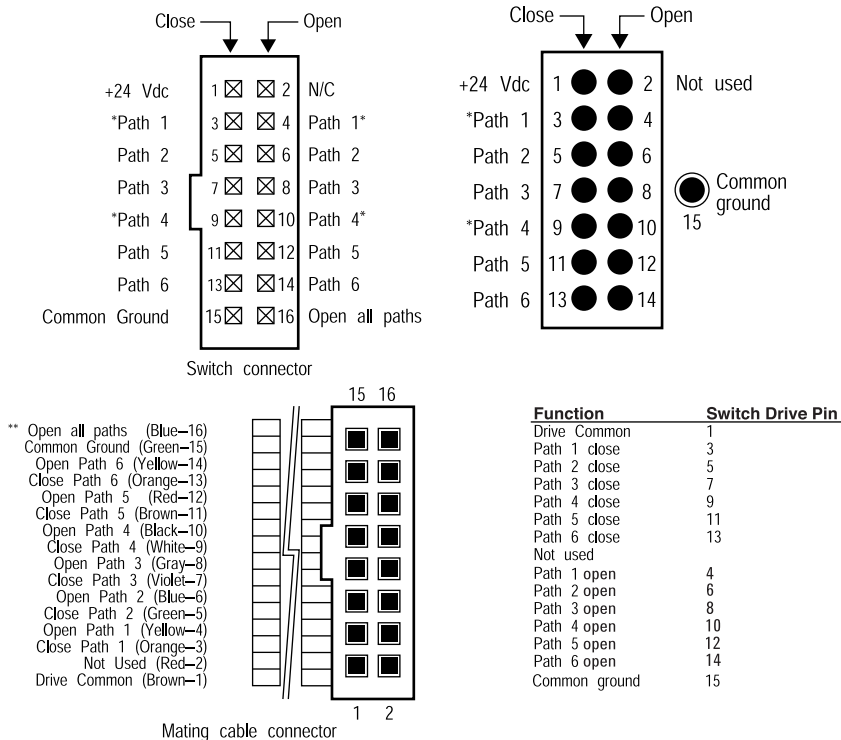

Warning:

1. Grounding both a “close” an “open” pin of the same path simultaneously will cause rapid cycling and premature failure of the switch.
2. Grounding any “close” pin and pin 16 simultaneously will cause rapid cycling and premature failure of the switch.

Standard

Option 100

Figure 8. Drive connection diagrams

* Paths 1 and 4 are not connected for the 87204A/B/C.
 ** “Open all paths” is not available with Option 100.

Troubleshooting

Symptom	Probable cause
1. Will not switch	<ul style="list-style-type: none"> • Not connected to supply • Supply voltage <20 V • Insufficient supply current • Pin 15 not connected to ground • Select line not at ground
2. Switch buzzes	<ul style="list-style-type: none"> • “Open” and “close” pins on same RF path are selected simultaneously • Pin 16 and any “closed” pins are selected simultaneously

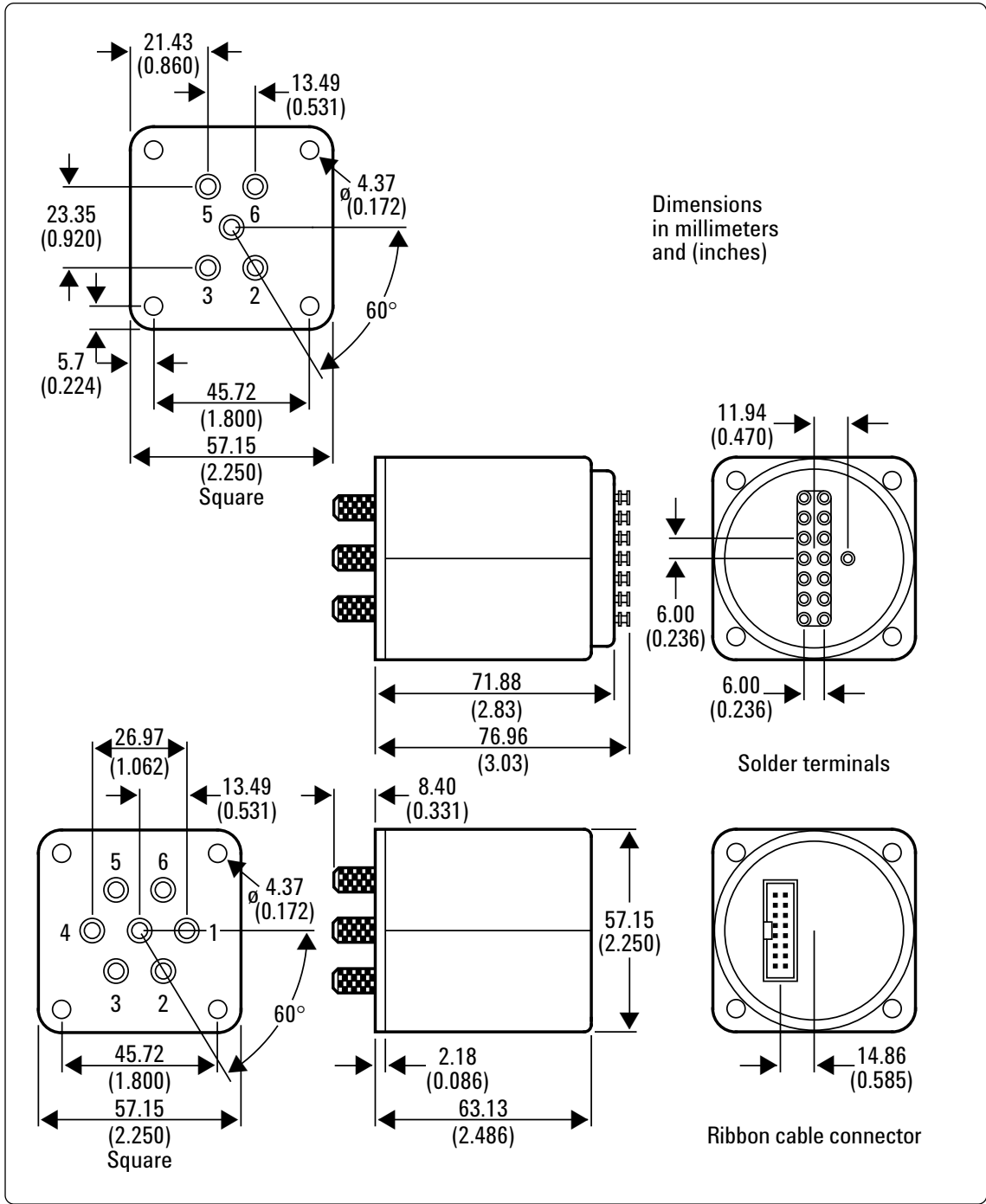

Figure 9. Product outlines

Ordering information

Switches

- 87204A** dc to 4 GHz, SP4T terminated
- 87204B** dc to 20 GHz, SP4T terminated
- 87204C** dc to 26.5 GHz, SP4T terminated
- 87206A** dc to 4 GHz, SP6T terminated
- 87206B** dc to 20 GHz, SP6T terminated
- 87206C** dc to 26.5 GHz, SP6T terminated
- Option 100** Solder terminals to replace ribbon cable
- Option UK6** Test data for commercial calibration with certificate

Drivers

11713A Attenuator switch driver

Drives up to 10 sections of switches or attenuators.

5061-0969 Accessory cable

Viking connector to bare tinned wires (60 inches long). Use to connect 11713A to 87204/206 with Option 100. One required with 87204 Option 100; two required with 87206 Option 100.

70611A Attenuator/switch driver

When expanded with up to 8 external (standard only) 84940A driver cards, the 70611A will drive up to 248 switch or attenuator sections. See below for accessories.

87130A Attenuator/switch driver

Drives up to 31 sections of switches or attenuators. When expanded with up to 7 external 84940A driver cards, the 87130A will drive up to 248 switch or attenuator sections. See below for accessories.

Accessories

84940A Switch driver card

Will drive up to 31 switch or attenuator sections. For use with 87130A and 70611A.

84941A Switch interface kit

Includes a signal distribution card and 70611-60008 accessory cable. For use with 87204/206 with Option 100.

11764-60008 Accessory cable (use with 87204/206)

16-pin DIP to (6) 4-pin Berg Connectors (30 inches long).

70611-60008 Accessory cable (use with 87204/206)

Option 100) (31) 52-inch cables, 4-pin Berg Connector to bare tinned wire.

Configuration guide

See publication 5963-2038E.

Agilent Technologies' Test and Measurement Support, Services, and Assistance

Agilent Technologies aims to maximize the value you receive, while minimizing your risk and problems. We strive to ensure that you get the test and measurement capabilities you paid for and obtain the support you need. Our extensive support resources and services can help you choose the right Agilent products for your applications and apply them successfully. Every instrument and system we sell has a global warranty. Support is available for at least five years beyond the production life of the product. Two concepts underlie Agilent's overall support policy: "Our Promise" and "Your Advantage."

Our Promise

Our Promise means your Agilent test and measurement equipment will meet its advertised performance and functionality. When you are choosing new equipment, we will help you with product information, including realistic performance specifications and practical recommendations from experienced test engineers. When you use Agilent equipment, we can verify that it works properly, help with product operation, and provide basic measurement assistance for the use of specified capabilities, at no extra cost upon request. Many self-help tools are available.

Your Advantage

Your Advantage means that Agilent offers a wide range of additional expert test and measurement services, which you can purchase according to your unique technical and business needs. Solve problems efficiently and gain a competitive edge by contracting with us for calibration, extra-cost upgrades, out-of-warranty repairs, and on-site education and training, as well as design, system integration, project management, and other professional engineering services. Experienced Agilent engineers and technicians worldwide can help you maximize your productivity, optimize the return on investment of your Agilent instruments and systems, and obtain dependable measurement accuracy for the life of those products.

By internet, phone, or fax, get assistance with all your test and measurement needs.

Online assistance:

www.agilent.com/find/assist

Phone or Fax

United States:

(tel) 1 800 452 4844

Canada:

(tel) 1 877 894 4414

(fax) (905) 282-6495

China:

(tel) 800-810-0189

(fax) 1-0800-650-0121

Europe:

(tel) (31 20) 547 2323

(fax) (31 20) 547 2390

Japan:

(tel) (81) 426 56 7832

(fax) (81) 426 56 7840

Korea:

(tel) (82-2) 2004-5004

(fax) (82-2) 2004-5115

Latin America:

(tel) (305) 269 7500

(fax) (305) 269 7599

Taiwan:

(tel) 080-004-7866

(fax) (886-2) 2545-6723

Other Asia Pacific Countries:

(tel) (65) 375-8100

(fax) (65) 836-0252

Email: tm_asia@agilent.com

Product specifications and descriptions in this document subject to change without notice.

Copyright © 1998, 2002

Agilent Technologies, Inc.

Printed in USA, August 13 2002

5965-3309E



Agilent Email Updates

www.agilent.com/find/emailupdates

Get the latest information on the products and applications you select.



Agilent Technologies