

Agilent 4268A 120 Hz/1 kHz Capacitance Meter

Data Sheet

1. Basic Specifications

Measurement parameters

- Cp-D, Cp-Q, Cp-Rp, Cp-G
- Cs-D, Cs-Q, Cs-Rs

Where:

Cp: Measured capacitance value using the parallel equivalent circuit model

Cs: Measured capacitance value using the series equivalent circuit model

D: Dissipation factor

Q: Quality factor (inverse of D)

G: Measured equivalent parallel conductance using the parallel equivalent circuit model

Rp: Measured equivalent parallel resistance using the parallel equivalent circuit model

Rs: Measured equivalent series resistance using the series equivalent circuit model

Measurement conditions

- Measurement signal
 - Frequency 120 Hz \pm 1%, 1 kHz \pm 0.05%
 - Level 0.1 V to 1.0 V, resolution 0.01 V, accuracy \pm 10%
 - Output mode Continuous, synchronous
 - Source delay time 0 to 1.000 s, resolution 1 ms (Effective when Output mode is set to the synchronous mode)
- Measurement cable length: 0 m, 1 m, 2 m (N.B., DC resistance of H_{CUR} and L_{CUR} cable : 0.3 Ω or less per cable)
- Measurement time mode: Short, Med, Long
- Measurement range selection: Automatic (Auto), manual (Hold)

- Measurement range:
 - When the measurement frequency is 120 Hz: 10 nF, 100 nF, 1 μ F, 10 μ F, 100 μ F, 1 mF.
 - When the measurement frequency is 1 kHz: 1 nF, 10 nF, 100 nF, 1 μ F, 10 μ F, 100 μ F.
- Averaging: 1 to 256 times
- Trigger mode: Internal (INT), manual (MAN), external (EXT), bus (BUS)
- Trigger delay time: 0 to 1.000 s, resolution 1 ms

Display range of measurement value

Parameter	Display range of measurement value
Cs, Cp	-9.9999 mF to -0.0001 nF, 0, 0.0001 nF to 9.9999 mF
D	-9.9999 to -0.0001, 0, 0.0001 to 9.9999
Q	-9999.9 to -0.1, 0, 0.1 to 9999.9
Rs, Rp	-999.99 M Ω to -0.01 m Ω , 0, 0.01 m Ω to 999.99 M Ω
G	-9.9999 kS to -0.0001 μ S, 0, 0.0001 μ S to 9.9999 kS
Δ %	-999.99% to -0.01%, 0, 0.1% to 999.99

Measurement accuracy

The accuracy is defined when all of the following conditions are met.

- Warm up time is 30 min or more.
- The OPEN and SHORT corrections have been performed.
- $D \leq 0.5$



Agilent Technologies

Accuracy of Cp and Cs

Accuracy A_e [%], which is the base of the accuracy of C_p and C_s (C_{pe} and C_{se} [%]), is calculated as follows:

Equation 1: Equation to calculate A_e

$$A_e = [A + B + K_L \beta + 100 E / (2.3 \pi^3 f^3 C_x)] / K_T$$

Where:

$\beta = C_r/C_x$ when $C_r \leq 100 \mu\text{F}$ (@120 Hz) or $C_r \leq 10 \mu\text{F}$ (@1 kHz)

$\beta = C_r/C_x + C_x/C_r$ when $C_r = 1 \text{ mF}$ (@120 Hz) or $C_r = 100 \mu\text{F}$ (@1 kHz) (n.b., if $\beta < 1$, $\beta = 1$)

C_x : Measurement value of C_p or C_s

C_r : Measurement range (1 nF, 10 nF, 100 nF, 1 μF , 10 μF , 100 μF , 1 mF)

f : Measurement frequency

A : Proportional error term (values are shown in Table 3)

B : Offset error term (values are shown in Table 3)

K_L : Coefficient for measurement signal level (values are shown in Table 1)

E : Residual when shorted, the value is $E = 600 \mu\Omega$ (fixed)

K_T : Coefficient for ambient temperature (values are shown in Table 2)

Table 1. Coefficient caused by measurement signal level, K_L

Measurement signal level, Level [V]	K_L
0.1 to 0.3	0.3/Level
0.31 to 0.5	0.5/Level
0.51 to 1.0	1.0/Level

Table 2. Coefficient caused by ambient temperature, K_T

Ambient temperature T [°C]	K_T
$0 \leq T < 18$	3
$18 \leq T \leq 28$	1
$28 < T \leq 55$	3

Table 3. Proportional term A and offset term B

Cr (measurement range)		120 Hz			1 kHz		
		SHORT	MED	LONG	SHORT	MED	LONG
1 nF	A	—	—	—	0.18	0.14	0.14
	B	—	—	—	0.062	0.052	0.049
10 nF	A	0.28	0.14	0.14	0.18	0.14	0.14
	B	0.1	0.054	0.05	0.041	0.036	0.035
100 nF	A	0.28	0.14	0.14	0.18	0.14	0.14
	B	0.077	0.037	0.035	0.041	0.036	0.035
1 μF	A	0.28	0.16	0.16	0.18	0.14	0.14
	B	0.077	0.037	0.035	0.041	0.036	0.035
10 μF	A	0.28	0.16	0.16	0.18	0.14	0.14
	B	0.077	0.037	0.035	0.041	0.036	0.035
100 μF	A	0.4	0.4	0.4	0.4	0.4	0.4
	B	0.077	0.037	0.035	0.066	0.049	0.044
1 mF	A	0.8	0.8	0.8	—	—	—
	B	0.106	0.052	0.045	—	—	—

C_{pe} and C_{se} [%] are derived from the calculated accuracy A_e [%], using the equation " $C_{pe} = C_{se} = \pm A_e$ [%]." Note that if the measured D value, D_x , exceeds 0.1, multiply C_{pe} and C_{se} by $(1 + D_x^2)$.

NOTE: If the secondary parameter is not D, calculate D using the equation in Table 4.

Table 4. Calculating D

Measurement parameter	Equation to calculate D
Cp-Q, CS-Q	$D = 1/Q_x$
Cp-G	$D = G_x / (2.3 \pi^3 f^3 C_{px})$
Cp-Rp	$D = 1 / (2.3 \pi^3 f^3 C_{px} R_{px})$
CS-Rs	$D = 2.3 \pi^3 f^3 C_{sx} R_{sx}$

In Table 4, C_{px} , Q_x , G_x , R_{px} , C_{sx} , and R_{sx} are measured values, and f is the measurement frequency.

Accuracy of D

The accuracy of D, D_e , is calculated as follows, using A_e [%]:

Equation 2: Equation to calculate D_e when $D_x < 0.1$ and $A_e \leq 10$ [%]

$$D_e = \pm A_e / 100$$

Equation 3: Equation to calculate D_e when $0.1 < D_x \leq 0.5$ and $A_e \leq 10$ [%]

$$D_e = \pm (A_e / 100) \sqrt{1 + D_x^2}$$

NOTE: The accuracy of D is expressed in an absolute value, instead of a percentage.

Accuracy of Q

The accuracy of Q, Q_e , is calculated as follows, using the accuracy of D, D_e :

Equation 4: Equation to calculate Q_e

$$Q_e = \pm Q_x \sqrt{1 + D_e^2}$$

Where: Q_x is the measured Q value. Note that if $Q_x \sqrt{1 + D_e^2}$ is 1 or more, $Q_e = \pm \infty$.

NOTE: The accuracy of Q is expressed in an absolute value, instead of a percentage.

Accuracy of G

The accuracy of G, G_e [%], is calculated as follows, using the base accuracy for Cp, A_e [%]:

Equation 5: Equation to calculate G_e

$$G_e = \pm A_e / (G_x / (2.3 \pi^3 f^3 C_{px}))$$

Where: G_x is the measured G value, C_{px} is the measured Cp value, and f is the measurement frequency. Note that, if D_x exceeds 0.1, multiply G_e by $(1 + D_x^2)$.

Accuracy of Rp

The accuracy of Rp, R_{pe} [%], is calculated as follows, using the accuracy of G, G_e [%]:

Equation 6: Equation to calculate R_{pe}

$$R_{pe} = \pm G_e / (1.7 G_e / 100)$$

Note that if G_e is 100[%] or more, $R_{pe} = \pm \infty$ [%].

Accuracy of Rs

The accuracy of Rs, R_{se} [%], is calculated as follows, using the base accuracy for Cp and Cs, A_e [%]:

Equation 7: Equation to calculate R_{se}

$$R_{se} = \pm A_e / (2.3 \pi^3 f^3 C_{px} \sqrt{1 + R_{sx}^2})$$

Where, R_{sx} is the measured Rs value, C_{sx} is the measured Cs value, f is the measurement frequency. Note that, if D_x exceeds 0.1, multiply R_{se} by $(1 + D_x^2)$.

Measurement support functions

- **Measurement signal level monitor function**

The measurement voltage and measurement current can be monitored.

- **Correction function**

The OPEN correction, SHORT correction, and LOAD correction are available.

- **Display**

40-digit 3 2-line LCD display.

- **Deviation measurement function**

Deviation from the reference value and the percent deviation from the reference value can be outputted as the result.

- **Comparator function**

Bin sort: Primary parameters can be sorted into 9 Bin, Out of Bins, and Aux Bin; the secondary parameters into High, In, and Low.

Limit setting: absolute mode, absolute tolerance mode, percent tolerance mode.

Bin count: 0–999999 can be counted.

- **Save/recall function**

Up to ten setting conditions can be saved/recalled using the built-in nonvolatile memory.

- **Resume function**

The instrument setting is automatically saved at power-off.

- **Key lock function**

The front-panel keys can be disabled.

- **Contact check function**

Automatic detection of contact failure between the measurement terminal and the DUT. (Available in the 4-terminal measurement)

- **GPIB interface**

Compliance with IEEE 488.1,2 and SCPI.

- **Handler interface**

Negative-logic input/output signals. Opto-isolated open collector signal.

Output signals Bin 1-Bin 9, Out of Bins, Aux_Bin, P-Hi, P-Lo, S-Reject, INDEX, EOM, Alarm, OVLD, NC.

Input signals Keylock, Ext-Trigger.

- **Scanner interface (Option 4268A-001)**

The OPEN/SHORT/LOAD correction of sixty-four channels are available.

NOTE: The 4268A has the following interface options.

Option 4268A-001: GPIB/handler/scanner interface

Option 4268A-002: GPIB/handler interface

2. General Specifications

Power supply

Voltage 90 VAC to 132 VAC, 198 VAC to 264 VAC

Frequency 47 Hz to 66 Hz

Power consumption 40 W maximum/100 VA maximum

Operation conditions

Temperature 0 °C to 45 °C

Humidity (≤ 40 °C, without condensation) 15% to 95% RH

Altitude 0 m to 2000 m

Non-operation conditions

Temperature -40 °C to 70 °C

Humidity (≤ 65 °C, without condensation) 0% to 90% RH

Altitude 0 m to 4572 m

EMC

- Compliance with *CISPR 11(1990)/EN 55011 (1991): Group 1, Class A*
- Compliance with *EN 61000-3-2 (1995)/IEC 61000-3-2 (1995)*
- Compliance with *EN 61000-3-3 (1995)/IEC 61000-3-3 (1994)*
- Compliance with *EN 50082-1 (1992)/IEC 61000-4-2 (1995): 4 kV CD, 8 kV AD*
- Compliance with *EN 50082-1 (1992)/IEC 61000-4-3 (1995): 3 V/m, 80% AM, 27 MHz to 1000 MHz*
- Compliance with *EN 50082-1 (1992)/IEC 61000-4-4 (1995): 0.5 kV Signal Lines, 1 kV Power Lines*

Safety

- Compliance with *IEC 61010-1 (1990) +A1 (1992) +A2 (1995), CAN/CSA C22.2 No.1010.1-92*

Outer dimensions

Approximately 320 mm (W) 3 100 mm (H) 3 450 mm (D)

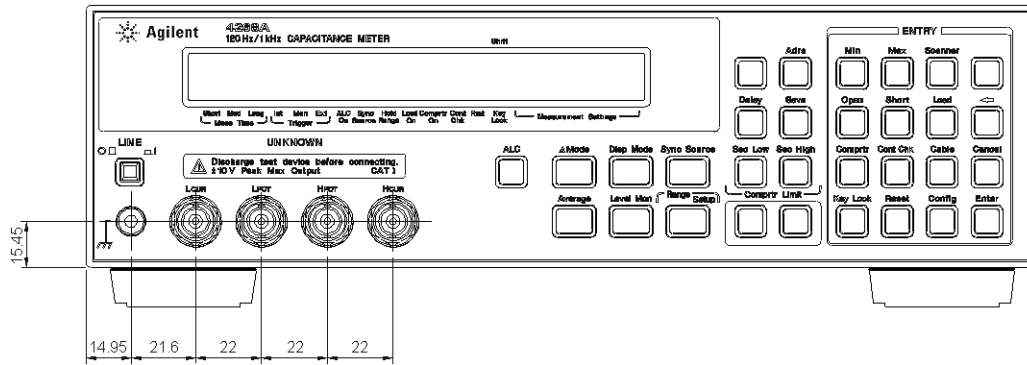

Figure 1. Front View

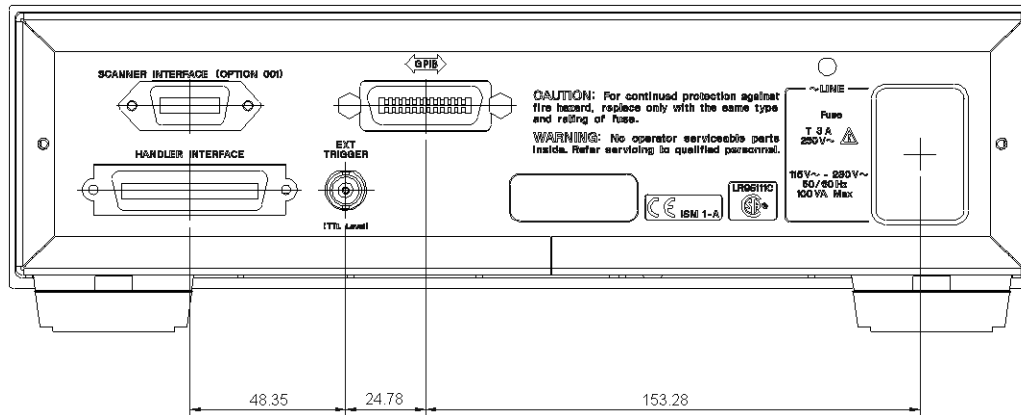

Figure 2. Rear View

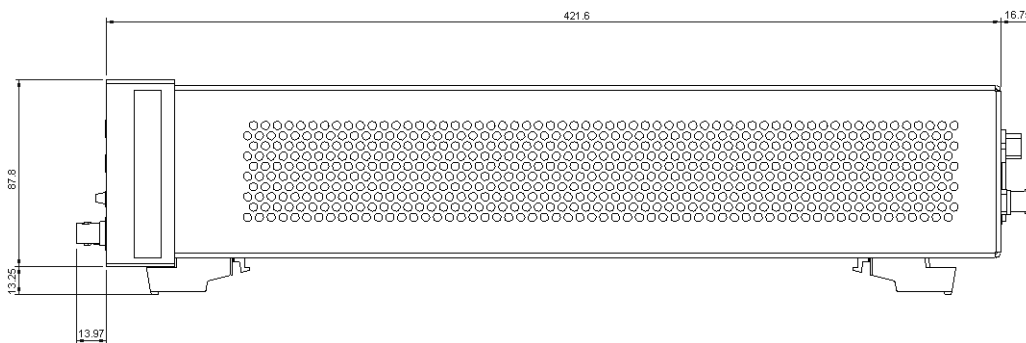

Figure 3. Side View

Weight

Approximately 5 kg

3. Supplemental Performance Characteristics

This section shows the reference data related to the operation of the 4268A other than the specifications.

The data are not specifications but typical characteristics useful to operate the instrument.

ALC (Auto Level Control) function

Operating measurement range setting

When the measurement frequency is 120 Hz:

100 μ F range, 1 mF range

When the measurement frequency is 1 kHz:

10 μ F range, 100 μ F range

If the ALC is to operate below its measurement range, the output of the signal voltage level will be judged depending upon whether the conditions below are satisfied or not.

Vset 3 0.9 < Vmon < Vset 3 1.1

Vset: measurement signal voltage setting

Vmon: Applied signal voltage to the DUT

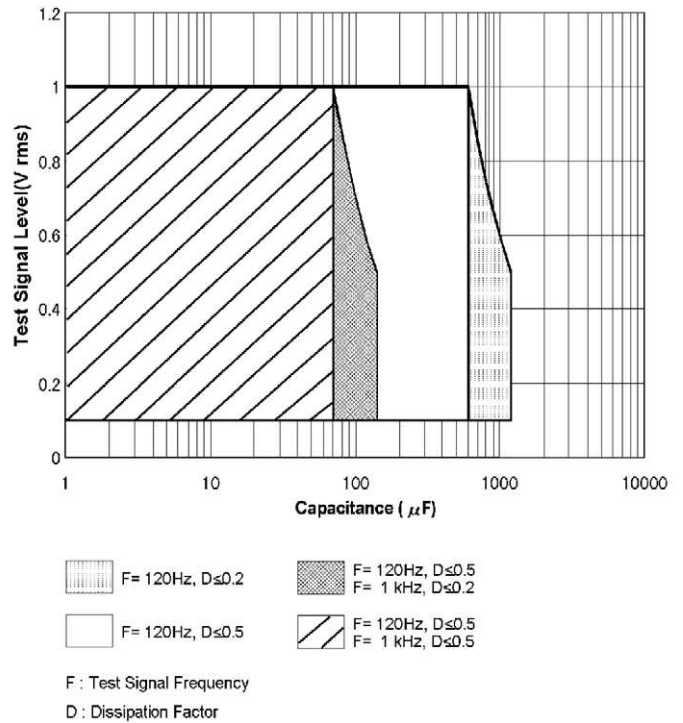

Figure 4. Operating range of the ALC function

Table 5. Operating range of the ALC

Measurement frequency	DUT		Measurement voltage	
	Dissipation factor	Capacitance C	Minimum	Maximum
120Hz	D \leq 0.2	C \leq 600 μ F	0.1 V	1.0 V
		600 μ F < C \leq 1200 μ F	0.1 V	(600 μ F/C)V
		C > 1200 μ F	Out of range	
120Hz	0.2 < D \leq 0.5	C \leq 600 μ F	0.1 V	1.0 V
		C > 600 μ F	Out of range	
		D > 0.5	All	Out of range
1 kHz	D \leq 0.2	C \leq 70 μ F	0.1 V	1.0 V
		70 μ F < C \leq 140 μ F	0.1 V	(70 μ F/C)V
		C > 140 μ F	Out of range	
1 kHz	0.2 < D \leq 0.5	C \leq 70 μ F	0.1 V	1.0 V
		C > 70 μ F	Out of range	
		D > 0.5	All	Out of range

Measurement time

Table 6 shows the measurement times when the measurement settings are as follows.

Display	Off
Measurement range mode	Hold
Averaging	1
Source delay time	0 ms
Trigger delay time	0 ms

Table 6. Measurement time

Measurement time	Short		Med		Long		Unit
	Min.	Max.	Min.	Max.	Min.	Max.	
T1 Analog measurement time	16 (20)	19 (23)	34 (38)	37 (41)	50 (54)	53 (57)	ms
T2 Measurement time	20 (24)	25 (30)	38 (42)	43 (48)	54 (58)	59 (64)	ms

The values in () are the measurement times when the contact check function is ON.

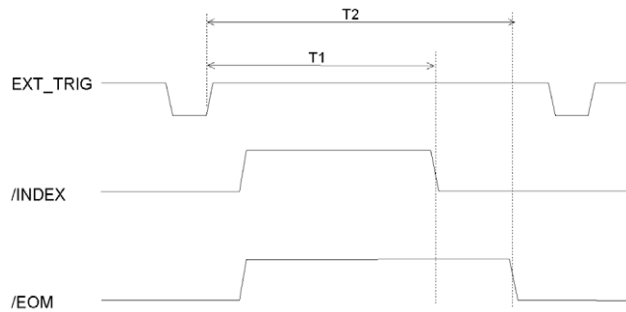

Table 7. Measurement range of capacitance

Measurement range	Recommended measurement range [F]		Effective measurement range [F]	
	Measurement frequency: 120 Hz	Measurement frequency: 1 kHz	Measurement frequency: 120 Hz	Measurement frequency: 1 kHz
1 nF	—	0.2 n to 2 n	—	0 to 2 n
10 nF	2 n to 20	2 n to 20	0 to 20 n	0 to 20 n
100 nF	20 n to 200 n	20 n to 200 n	0 to 200	0 to 200
1 μF	0.2 μ to 2 μ	0.2 μ to 2 μ	0 to 2 μ	0 to 2 μ
10 μF	2 μ to 20 μ	2 μ to 20 μ	0 to 20 μ	0 to 20 μ
100 μF	20 μ to 200 μ	20 μ to 200 μ	0 to 200 μ	0 to ∞
1 mF	0.2 m to 2 m	—	0 to ∞	—

Measurement range

The recommended measurement range and effective measurement range are shown in Table 7 (where the dissipation factor $D \leq 0.5$). Recommended Measurement Ranges are given for better measurement accuracy while Effective Measurement Ranges are provided to avoid overloads.

Contact check function

Effective measurement range

($D \leq 0.5$)

Minimum contact impedance that can be detected

5 MΩ

Table 8. Effective measurement range ($D \leq 0.5$)

Measurement range	Effective measurement range [F]			
	Measurement frequency: 120 Hz		Measurement frequency: 1 kHz	
	Minimum	Maximum	Minimum	Maximum
1 nF	—	—	100 p	2 n
10 nF	1 n	20 n	1 n	20 n
100 nF	10 n	200 n	10 n	200 n
1 μ F	100 n	2 μ	100 n	2 μ
10 μ F	1 μ	20 μ	1 μ	20 μ
100 μ F	10 μ	200 μ	10 μ	200 μ
1 mF	200 μ	2 μ	—	—

Measurement signal source output impedance

When the auto level control function is OFF
 1.5 Ω or less (without extention cable)

When the auto level control function is ON
 When the measurement frequency is 120 Hz
 Measurement range: 10 nF to 10 μ F

1.5 Ω or less (without extention cable)

Measurement range: 100 μ F to 1 mF

0.1 Ω or less (without extention cable)

When the measurement frequency is 1 kHz

Measurement range: 1 nF to 1 μ F

1.5 Ω or less (without extention cable)

Measurement range: 10 μ F to 100 μ F

0.1 Ω or less (without extention cable)

Maximum capacitor voltage Range of capacitance C of measured DUT

250 V	$C < 32 \mu\text{F}$
$\sqrt{2/C}$ V	$C \geq 32 \mu\text{F}$

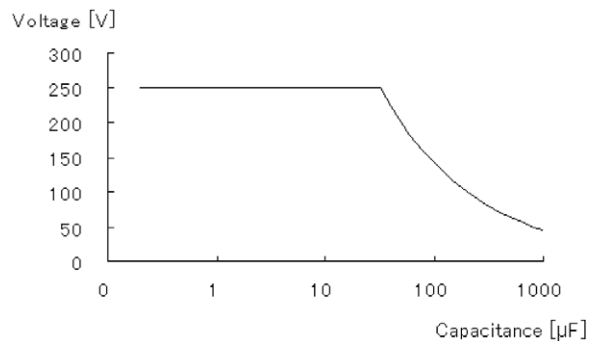

Figure 5. Maximum capacitor voltage

Measurement voltage monitor function

Accuracy $\pm(2\% + 2 \text{ mV})$

Resume function

Data holding time 72 hours (23 $^{\circ}$ C ± 5 $^{\circ}$ C)

Measurement circuit protection

The following table shows the maximum discharge withstand voltage below which the internal circuit is protected even if a charged capacitor is connected to UNKNOWN terminal.

NOTE: Connect the charged capacitor to the UNKNOWN terminals or test fixture after it has discharged.

Sample calculation of measurement accuracy

This section gives you sample calculations of the measurement accuracy for each measurement parameter, assuming the measurement conditions shown below.

Measurement frequency	1 kHz
Measurement level	1 V
Measurement range	10 μ F
Measurement time	Med
Ambient temperature	28 °C

Measurement parameter: Cp (or Cs)-D

The following sample calculation shows you how to calculate the Cp (or Cs) accuracy, C_{pe} or C_{se} [%], and the D accuracy, D_e , assuming that the measured Cp (or Cs) value is 9.8765 μ F and the measured D value is 0.0123.

The measurement range is 10 μ F and the measured Cp (or Cs) value is 9.8765 μ F, so therefore,

$$\begin{aligned}\beta &= 10 \mu / 9.8765 \mu = 1.0125 \\ \text{measurement frequency } f &= 1000 \\ A &= 0.14, B = 0.036 \text{ (from Table 3)} \\ K_L &= 1.0/1.0 = 1 \text{ (from Table 1)} \\ E &= 0.0006 \\ \beta &= 10 \mu / 9.8765 \mu = 1.0125 \\ K_T &= 1 \text{ (from Table 2)}\end{aligned}$$

Substituting these values into the equation yields the following result:

$$A_e = [0.14 + 0.036 \times 1 \times 1.0125 + 100 \times 0.0006 \times (2 \times \pi \times 1000 \times 9.8765 \times 10^{-6})] \times 1 = 0.180 \text{ [%]}$$

Because $D < 0.1$, C_{pe} or C_{se} is ± 0.180 [%]. On the other hand, the measured D value is 0.0123 and the calculated A_e value is 0.180[%], and therefore, using Equation 2, $D_e = \pm 0.180/100 > \pm 0.0018$ is obtained. As a result, the true Cp (or Cs) value falls within $9.8765 \pm (9.8765 \times 0.0178)$ [μ F], *i.e.*, a range between 9.8587 and 9.8943 [μ F]; the true D value, 0.0123 ± 0.0018 , falls within a range between 0.0105 and 0.0141.

Measurement parameter: Cp (or Cs)-Q

The following sample calculation shows you how to calculate the Cp (or Cs) accuracy, C_{pe} (or C_{se}) [%], and the Q accuracy, Q_e , assuming that the measured Cp (or Cs) value is 9.8765 μ F and the measured Q value is 9.8765.

The measurement frequency is 1 kHz and the measured Cp (or Cs) is 9.8765 μ F. By performing calculation in the same way as Cp-D, $A_e = 0.180$ [%] is obtained. Because $D = 1/9.8765 > 0.1013 > 0.1$, multiply $(1 + 0.1013^2)$. The calculated C_{pe} or C_{se} is ± 0.182 [%]. On the other hand, the calculated D value is 0.1013 and the calculated A_e value is 0.180 [%]. To obtain D_e , first, use Equation 10-3. The result is

$$D_e = \pm(0.180/100) \times (1 + 0.1013) \times \sqrt{1 + 0.1013^2} > \pm 0.0020$$

Then, use the obtained D_e and Equation 4. The result is $Q_e = \pm 9.8765^2 \times 0.0020 / (17 \times 9.8765 \times 0.0020) = -0.1913 \sim 0.1990$. As a result, the true Cp (or Cs) value falls within a range between 9.8586 and 9.8944 [μ F]; the true Q value falls within a range between 9.6852 and 10.076.

Measurement parameter: Cp-G

The following sample calculation shows you how to calculate the Cp accuracy, C_{pe} [%], and the G accuracy, G_e [%], assuming that the measured Cp value is 9.8765 μ F and the measured G value is 0.0123.

$$D = 0.0123 / (2 \times \pi \times 1000 \times 9.8765 \times 10^{-6}) > 0.1982 > 0.1$$

Therefore, multiply the calculated A_e value by $(1 + 0.1982^2)$. The result of C_{pe} is ± 0.187 [%]. On the other hand, from Equation 5,

$$G_e = \pm 0.180 / (0.0123 / (2 \times \pi \times 1000 \times 9.8765 \times 10^{-6})) = \pm 0.908 \text{ [%]}$$

Because $D > 0.1$, multiply by $(1 + 0.1982^2)$ in the same way as C_{pe} . The final result of G_e is ± 0.943 [%].

Measurement parameter: Cp-Rp

The following sample calculation shows you how to calculate the Cp accuracy, Cpe [%], and the Rp accuracy, Rpe [%], assuming that the measured Cp value is 9.8765 μ F and the measured Rp value is 123.45 Ω .

$$D = 1 / (2 \times 3 \times \pi \times 1000 \times 9.8765 \times 10^{-6} \times 123.45) > 0.1305 > 0.1$$

Therefore, multiply the calculated Ae by $(1 + 0.1305^2)$. The result of Cpe is ± 0.183 [%]. On the other hand, $Gx = 1/Rpx = 1/123.45 = 0.0081$. Therefore, perform the calculation in the same way as Cp-G. The result of Ge is ± 1.402 [%]. From Equation 6, $Rpe = \pm 1.402 / (1 + 1.042/100) = -1.383 \sim 1.422$ [%] is obtained.

Measurement parameter: Cs-Rs

The following sample calculation shows you how to calculate the Cs accuracy, Cse [%], and the R accuracy, Rse [%], assuming that the measured Cs value is 9.8765 μ F and the measured Rs value is 2.3456 Ω .

$$D = 2 \times 3 \times \pi \times 1000 \times 9.8765 \times 10^{-6} \times 2.3456 > 0.1456 > 0.1$$

Therefore, multiply the calculated Ae by $(1 + 0.1456^2)$. The result of Cse is ± 0.182 [%]. On the other hand, from Equation 7, $Rse = 0.180 / (2 \times \pi \times 1000 \times 9.8765 \times 10^{-6} \times 2.3456) > 1.237$ [%]. Because $D > 0.1$, multiply by $(1 + 0.1456^2)$ in the same way as Cse . The final result of Rse is ± 1.263 [%].

4. GPIB Command Information

Table 9 lists the Agilent 4268A GPIB commands sorted according to function. Table 9 additionally provides compatible Agilent 4278A¹ GPIB commands.

Refer to Chapter 6, *GPIB Command Reference*, of the 4268A operation manual for more detail. Refer to the 4278A operation manual for its detailed information.

Table 9. GPIB command table (4268A command vs. 4278A command)

Function	Setting/operation	GPIB command		
		Agilent 4268A	Agilent 4278A	
Measurement condition	Reset		:SYSTem:PRESet, *RST	*RST
	Signal	Frequency	:SOURce:FREQUency[:CW]	FREQ1, FREQ2
		Level	:SOURce:VOLTage[:Level][:MMediate][:AMPLitude]	OSC =
		ALC	:SOURce:VOLTage:ALC[:STATe]	None
		Output mode	:SOURce:VOLTage:MODE	None
		Source delay time	:TRIGger[:SEQUence1]:DELay	None
		Parameter	Primary	:CALCulate1:FORMat
	Secondary		:CALCulate2:FORMat	
	Deviation measurement	On/off	:CALCulate1:MATH:STATe :CALCulate2:MATH:STATe	None
		Mode	:CALCulate1:MATH:EXPRession:NAME, :CALCulate2:MATH:EXPRession:NAME	None
		Reference value	:DATA[:DATA]	None
	Range	Auto range	[:SENSe][:FIMPedance]:RANGe:AUTO	RA0
		Range	[:SENSe][:FIMPedance]:RANGe:UPPer]	RA1, RA2, RA3, RA4, RA5, RA6, RA7
	Measurement time		[:SENSe][:FIMPedance]:APERture[:MODE]	ITIM1, ITIM2, ITIM3
	Average	On/off	[:SENSe]:AVERage[:STATe]	None
		Count	[:SENSe]:AVERage:COUNt	AVE=
	Cable length		:CALibration:CABLe	CABL0, CABL1, CABL1
	Trigger delay time		:TRIGger:SEQUence2:DELay	DTIM=
	Trigger mode		:TRIGger[:SEQUence1]:SOURce	TRIG1, TRIG2, TRIG3
Trigger	Triggering	:TRIGger[:SEQUence1][:IMMediate], *TRG	*TRG	
	Trigger system reset	:ABORt	None	
	Trigger system operation	:INITiate[:IMMediate]	None	
	Trigger system operation setting	:INITiate:CONTinuous	None	
Data output	Data transfer format setting	:FORMat[:DATA]	DFMT1, DFMT2	
	Read data	:DATA[:DATA], :FETCh?, :READ?	DATA?	
	Data transfer format	:FORMat[:DATA]	None	
	Data bufferSetting	Data feed	:DATA:FEED	None
		Feed (yes or no)?	:DATA:FEED:CONTRol	None
Size:number of points		:DATA:POINts	None	

1. Denotes the 4278A is obsolete.

Table 9 continued.

Function	Setting/operation		GPIB command	
			Agilent 4268A	Agilent 4278A
Comparator function	On/off		:CALCulate:COMParator[:STATe]	COMP0, COMP1
	Primary Parameter limit	On/off	:CALCulate:COMParator:PRIMary:BIN1:STATe, :CALCulate:COMParator:PRIMary:BIN{2-9}:STATe	None
		Limit setting	:CALCulate:COMParator:PRIMary:BIN1, :CALCulate:COMParator:PRIMary:BIN{2-9}	BIN 1=, BIN2=, BIN3=, BIN4=, BIN5=, BIN6=, BIN7=, BIN8=, BIN9=, BLIM=
		Mode setting	:CALCulate:COMParator:MODE	None
		Reference value	:CALCulate:COMParator:PRIMary:NOMinal	NOM=
	Secondary parameter limit	On/off	:CALCulate:COMParator:SECondary:STATe	None
		Area	:CALCulate:COMParator:SECondary:LIMit	SLIM=
	AUX BIN function	On/off	:CALCulate:COMParator:AUXBin	AUX0, AUX1
	BIN count function	On/off	:CALCulate:COMParator:COUNt[:STATe]	CNT0, CNT1
		Clear count	:CALCulate:COMParator:COUNt:CLEar	RCNT
		Count data	:CALCulate:COMParator:COUNt:DATA?	COUN?
	Correction function	User correction function on/off		[:SENSe]:CORRection[:STATe]
Load correction function on/off		[:SENSe]:CORRection:COLLect:METNod	STD0, STD1	
Measure correction data		[:SENSe]:CORRection:COLLect[:ACQuire]	XOP, XSH, XST	
Set correction data		[:SENSe]:CORRection:DATA	None	
Read data correction		[:SENSe]:CORRection:DATA	OPM?, STM?, STM	
Standard value for load correction		Standard value	[:SENSe]:CORRection:CKIT:[:STANdard3]	CSTD=, DSTD=, GSTD=, STR?
		Parameter type	[:SENSe]:CORRection:CKIT:STANdard3:FORMat	SPAR1, SPAR2
Scanner function	Multi channel correction	On/off	[:SENSe]:CORRection:MULTiple[:STATe]	MCOM0, MCOM1
		Channel number setting	[:SENSe]:CORRection:MULTiple:CHANnel	CNO=
		Load standard value (ALL or each channel)	[:SENSe]:CORRection:MULTiple:CKIT:STANdard3[:STATe]	None
Other measurement support functions	Current monitor	On/off	:CALCulate3:MATH:STATe	None
		Read display data	:DATA[:DATA]	None
	Voltage monitor	On/off	:CALCulate4:MATH:STATe	None
		Read display data	:DATA[:DATA]	None
	Contact check function on/off		[:SENSe][:FIMPedance]:CONtact:VERify	None
	Save/recall	Save	*SAV	STO
		Recall	*RCL	LOAD
	Display	On/off	:DISPlay[:WINDow][:STATe]	None
		Display setting	:DISPlay[:WINDow]:TEXT1 [:DATA]:DIGit	DDIG4, DDIG5, DDIG6
		Display page setting	:DISPlay[:WINDow]:TEXT2:PAGE	VMON0, VMON1, VMON2, VMON3, VMON4, VMON5, VMON6
	Key lock function on/off		:SYSTem:KLOCK	None
	Beep output	On/off	:CALCulate:COMParator:BEEPer[:STATe]:SYSTem: BEEPer:STATe	None
		Mode	:CALCulate:COMParator:BEEPer:CONDition	None
		Beep sound output	:SYSTem:BEEPer[:IMMEDIATE]	None

Table 9 continued.

Function	Setting/operation	GPIB command		
		Agilent 4268A	Agilent 4278A	
Status reporting structure	Clear	*CLS	*CLS	
	Read status byte register value	*STB?	*STB?	
	Mask setting for service request Enable register	*SRE	*SRE	
	Standard event	Read register value	*ESR?	None
	Status register	OPC bit setting when operation completes	*OPC	None
		Mask setting for enable register	*ESE	None
	Standard	Clear	:STATus:PRESet	None
	Operation Status group	Read register value	:STATus:OPERation:CONDition?, :STATus:QUESTionable:CONDition	None
		Mask setting for enable register	:STATus:OPERation:ENABLE, :STATus:QUESTionable:ENABLE	None
		Read event register value	:STATus:OPERation[:EVENT]?, :STATus:QUESTionable[:EVENT]	None
Others	Self test operation	*TST?	TENT, TNO=, TST, TAB, TDA?, TEND	
	Read product information	*IDN?	*IDN?	
	Read option information	*OPT?	*OPT?	
	Read 1 when operation completes	*OPC?	None	
	Read error Information	:SYSTem:ERRor?	ERR?	
	Read SCPI version	:SYSTem:VERSion?	None	
	Wait for command	*WAI	None	

5. Handler Interface Information

Outputting the comparator result

Via the handler interface, the sorting result of the comparator is outputted. The relationship between the comparator result and the output signals of the handler interface (/BIN1- /BIN9, /AUX BIN, /OUT OF BINS, /PHI, /PLO, /SREJ) is shown below.

NOTE: If the comparator function is OFF, the signals are not outputted except for /INDEX, /EOM, and /ALARM. /INDEX and /EOM are kept outputted (Low). /ALARM is outputted when an error occurs, in the same way as when the comparator is ON. Note that EXT TRIG is valid, regardless of ON/OFF of the comparator function, if the trigger mode is Ext (external).

Pin assignment of the Input/output signals

Figure 7 shows the pin assignment of each input/output signal of the handler interface connector. Table 10 describes the input/output signals.

NOTE: The / (slash) before signal names means that the signal is negative logic (active low).

Output from /BIN1~9, /OUT_OF_BINS, /AUX_BIN

Output from /PHI, /PLO, /SREJ

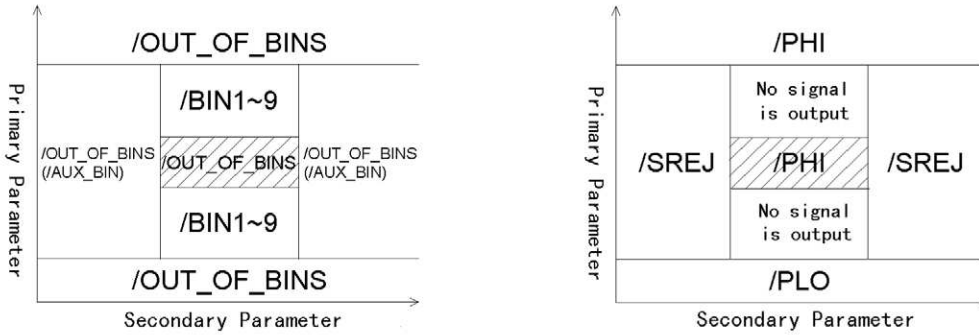

Signals encircled with () are outputted when the AUX BIN function is ON.
 Signals shaded with [diagonal lines] are outputted if there is a gap between limit ranges of BINs for primary parameters.

Figure 6. Output of the comparator result to the handler interface

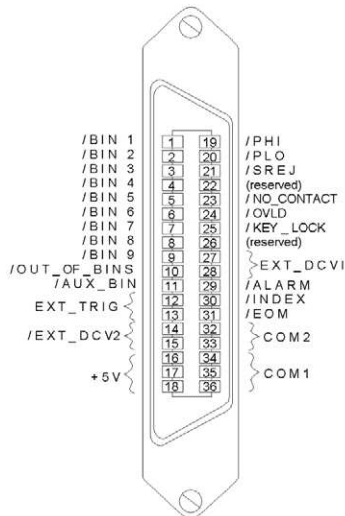

Figure 7. Pin assignment of the handler interface connector

Table 10. Description of the handler interface input/output signals

Pin number	Signal name	Description
1	/BIN1	Screening result signals (output). A BIN signal for the screening result (one of pins 1 to 11) goes Low. Note that, if a contact check failure occurs or if measurement is impossible, these signals do not go Low.
2	/BIN2	
3	/BIN3	
4	/BIN4	
5	/BIN5	
6	/BIN6	
7	/BIN7	
8	/BIN8	
9	/BIN9	
10	/OUT_OF_BINS	
11	/AUX_BIN	
12,13	EXT_TRIG	External trigger signals (input). These are valid when the trigger mode is set to EXT (external). The rising edge of a pulse generates a trigger.
14,15	EXT_DCV2	External DC voltage (input). These supply voltage for the input signals (EXT TRIG, /KEY LOCK) and the operation output signals (/ALARM, /INDEX, /EOM). The input voltage range is from + 5 V to + 15 V.
16,17,18	+ 5V	Internal DC voltage (output).
19	/PHI	Over primary parameter upper limit signal (output). If the upper limit value of BIN1 to BIN9 is exceeded, it goes Low.
20	/PLO	Below primary parameter lower limit signal (output). If the lower limit value of BIN1 to BIN9 is not reached, it goes Low.
21	/SREJ	Secondary parameter out-of-limit signal (output). If the secondary parameter goes out of the allowable limit, it goes Low.
22	(reserved)	Not used at present. Do not connect anything.
23	/NO_CONTACT	Contact check failure signal (output). If the contact check is failed, it goes Low.
24	/OVLD	Measurement impossibility signal (output). If the measurement is impossible at the analog measurement part, it goes Low.
25	/KEY_LOCK	Key lock signal (input). Setting this signal to Low disables the use of all the front panel keys of the Agilent 4268A.
26	(reserved)	Not used at present. Do not connect anything.
27, 28	EXT DCV1	External DC voltage (input). These supply voltage for the judgement output signals (/BIN1-/BIN9, /AUX BIN, /OUT OF BINS, /PHI, /PLO, /SREJ, /OVLD, /NO CONTACT). The input voltage range is from +5 V to +24 V.
29	/ALARM	Error occurrence signal (output). In the case of abnormal selftest result, momentary failure of the power supply, or abnormal operation of a certain circuit, it goes Low. In the case of momentary failure of the power supply, it is Low only while the power supply is down.
30	/INDEX	Analog measurement completion signal (output). When the analog measurement is completed, it goes Low. When the handler receives this signal, it gets ready for the next DUT to be connected. Note that, until it receives the /EOM signal, measurement data cannot be obtained.
31	/EOM	Measurement cycle completion signal (output). When a series of measurement steps is completed and the measurement data screening result becomes valid, it goes Low.
32, 33	COM2	Common for the external DC voltage of EXT DCV2 (pins 14 and 15).
34, 35, 36	COM1	Common for the external DC voltage of EXT DCV1 (pins 27 and 28).

Timing chart

Figure 8 shows the timing chart. T1 through T5 indicate the time periods described in the following table. The undefined section in /Data indicates that the 4268A is processing data after analog measurement and therefore the output signal is invalid.

Time	Minimum	Maximum
T1 Trigger pulse width	1[μ s]	—
T2 Measurement start delay time	—	600[μ s] ¹
T3 Screening result output hold time	0[μ s]	—
T4 Screening result output setup time	1[μ s]	—
T5 Trigger setup time	0[μ s]	—

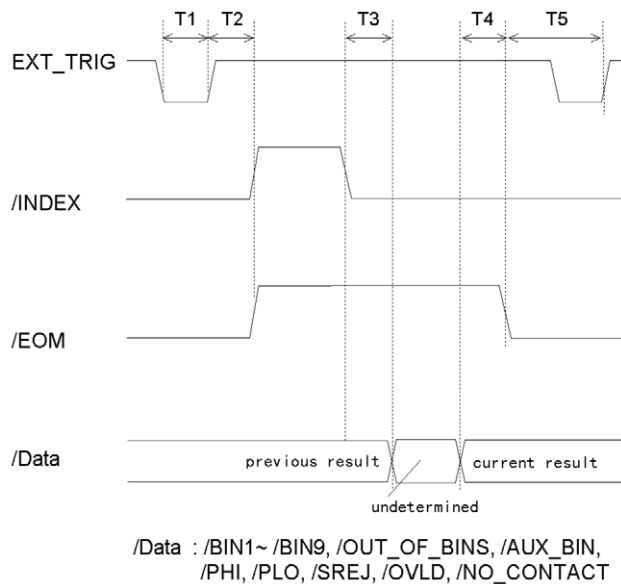

Figure 8. Timing chart

Electrical characteristics

Output signals

Each output signal is outputted via open collector using photo-coupler. Voltage of each output is obtained by connecting pull-up resistors, inside or outside of the 4268A. The output signals can be divided into two groups: judgment output signals and operation output signals. Table 11 shows the electrical characteristics of the output signals. Figure 9 and Figure 10 show the circuit diagram of the judgment output signals and that of the operation output signals, respectively.

Table 11. Electrical characteristics of the handler interface output signals

Output signal	Output voltage [V]		Maximum current [mA]
	Low	High	
Judgment output signals /BIN1 to /BIN9, /AUX_BIN, /OUT_OF_BINS, /PHI /PLO, /SREJ, /OVLD, /NO_CONTACT	0 to 0.5	DCV1 ²	6
Operation output signals /INDEX, /EOM, /ALARM	0 to 0.5	DCV2 ³	6

1. When the display has been turned off.
2. +5 V or +12 V when internal power supply used.
EXT_DCV2(+5 V to +15 V) when external power supply used.
3. +5 V or +12 V when internal power supply used.
EXT_DCV2(+5 V to +15 V) when external power supply used.

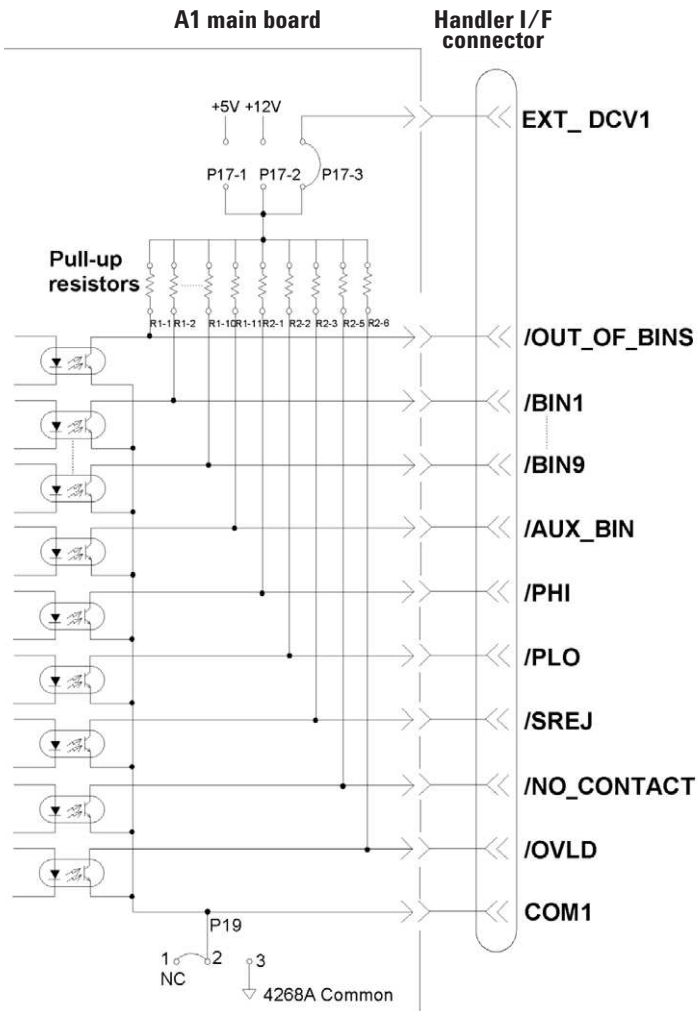

Figure 9. Circuit diagram of the handler interface input signals

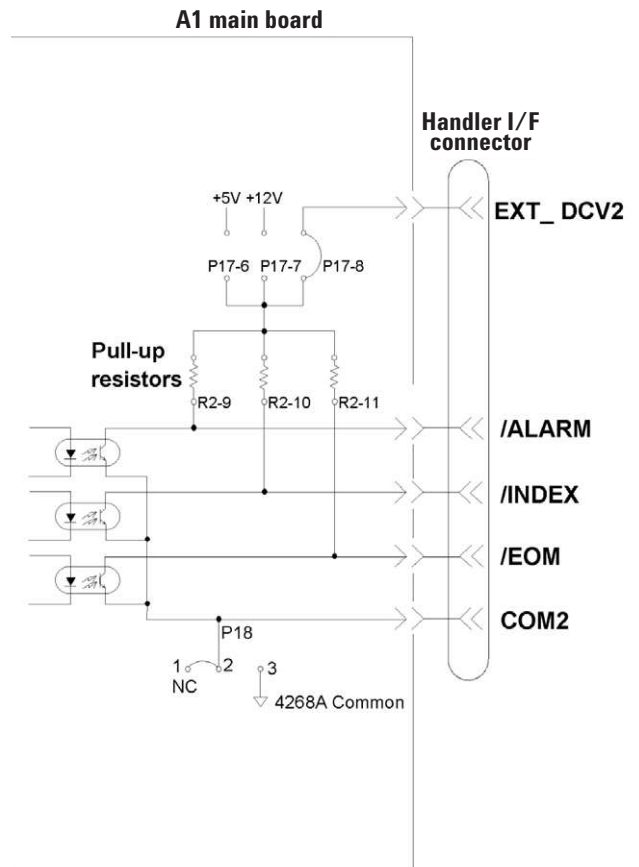

Figure 10. Circuit diagram of the handler interface operation output signals

Input signals

Each input signal is connected to the LED (cathode side) of the photo-coupler. The LED (anode side) is connected to the pull-up power supply voltage. Table 12 shows the electrical characteristics of the input signals. Figure 11 shows the circuit diagram of the input signals. The amount of the current flowing through the LED varies, depending on the pull-up power supply voltage and the setting of the pull-up resistor setting switch (S2). For information on the pull-up power supply voltage and the setting of S2, refer to *Preparation for Using the Handler Interface* on page 20.

Table 12. Electrical characteristics of the handler interface input signals

Input signal	Input voltage [V]		Input current (at Low) [mA] (typical) Pull-up power supply voltage DCV2 ¹		
	Low	High	5V	12V	15V
EXT_TRIG	0 to 1	DCV2 ¹	3.7	4.6	5.9
/KEY_LOCK	0 to 1	DCV2 ¹	5	14	18

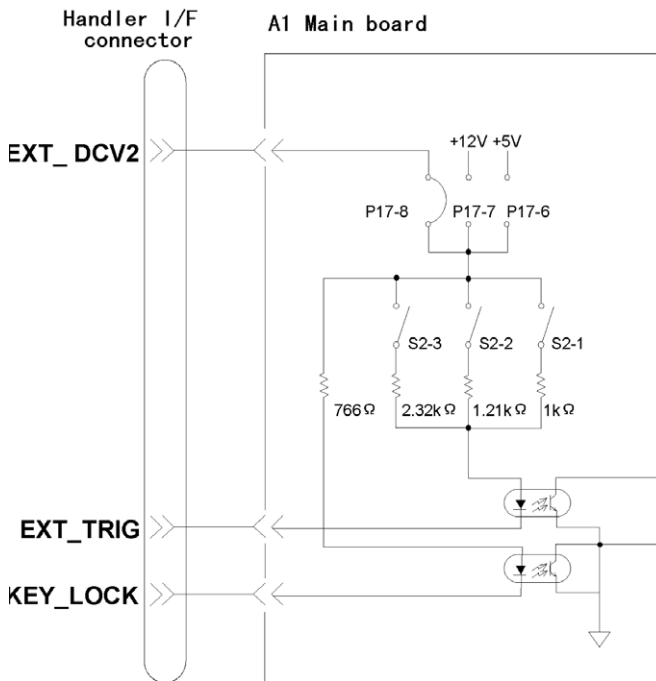

Figure 11. Circuit diagram of the handler interface input signals

1. +5V or +12V when internal power supply used EXT_DCV2 (+5V to +15V) when external power supply used

Power supply

The power supply for the judgment output signal pull-up and that for the operation output signal pull-up and input signal drive can be set separately. As shown below, you can select them from +5 V or +12 V of the internal power supply or external power supply. For information on how to select the power supply, refer to *Setting the jumper (P17)* on page 20.

Table 13. Selecting the input/output signal pull-up/drive power supply

	Internal power supply		External power supply
Judgment output signal pull-up power supply	+ 5 V	+ 12 V	EXT_DCV1 +5 V to +24 V
Operation output signal pull-up power supply and input signal drive power supply	+ 5 V	+ 12 V	EXT_DCV2 +5 V to +15 V

Table 14. Setting of circuit common

	When internal power supply used	When external power supply used
Judgment output signal pull-up power supply	Internal common	COM1
Operation output signal pull-up power supply	Internal common	COM2

Preparation for using the handler interface

Before using the handler interface, you are required to set the input/output signal drive/pull-up power supplies and the pull-up resistors.

NOTE: The information described here is designed for Internal Use Only in the Agilent service center. Request the service center to perform the setting described here as necessary to use the handler interface.

Setting the drive/pull-up power supply

The drive/pull-up power supply is set using the jumper (P17) and the DIP switch (S2) on the A1 main board. For information on the location and socket numbers of P17, and the location and switch numbers of S2, refer to Figure 12.

Setting the jumper (P17)

P17-6, P17-7, and P17-8 let you set the operation output signal pull-up and input signal drive power supply (DCV2). Setting one of the following jumpers selects external power supply (EXT DCV2), internal power supply (+12 V), or internal power supply (+5 V).

Socket number	Power supply setting when the jumper is set (shorted)	Factory setting
P17-8	For the operation output signal pull-up and input signal drive power supply, external power supply (EXT DCV1) is specified.	Short
P17-7	For the operation output signal pull-up and input signal drive power supply, internal power supply (+12 V) is specified.	Open
P17-6	For the operation output signal pull-up and input signal drive power supply, internal power supply (+5 V) is specified.	Open

NOTE: Set (short) only one of P17-6, P17-7, and P17-8. Do not set (short) two or more at the same time.

NOTE: P17-5 and P17-4 are not used at present. Do not connect anything.

P17-3, P17-2, and P17-1 let you set the judgment output signal pull-up power supply (DCV1). Setting one of the following jumpers selects external power supply (EXT DCV1), internal power supply (+12 V), or internal power supply (+5 V).

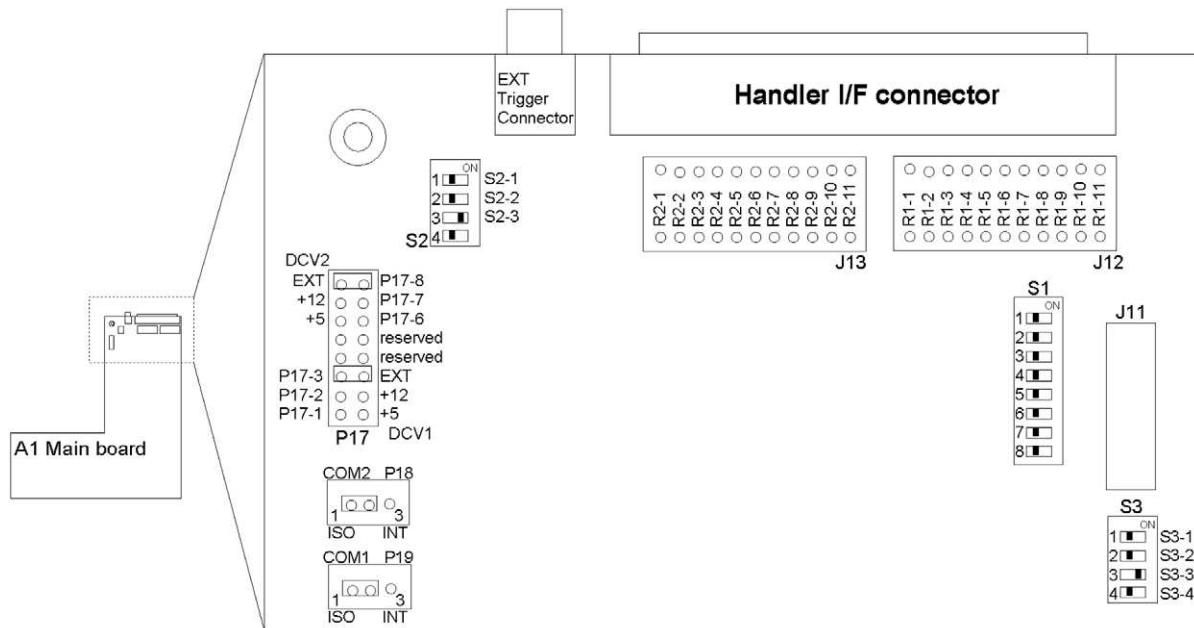

Figure 12. A1 main board

Socket number	Power supply setting when the jumper is set (shorted)	Factory setting
P17-3	For the judgment output signal pull-up power supply, external power supply (EXT DCV1) is specified	Short
P17-2	For the judgment output signal pull-up power supply, internal power supply (+ 12 V) is specified.	Open
P17-1	For the judgment output signal pull-up power supply, internal power supply (+5 V) is specified.	Open

NOTE: Set (short) only one of P17-3, P17-2, and P17-1. Do not set (short) two or more at the same time. The external power supplies (EXT DCV1 and EXT DCV2) must be set within the following voltage ranges.

	Voltage range (V)
EXT_DCV1	+5 to +24
EXT_DCV2	+5 to +15

Setting the jumpers (P18, P19)

P17-5 and P17-4 let you set the circuit common.

Socket number	Circuit common setting when the jumper is set (shorted)	Factory setting
P18 1-2	External power supply's (EXT DCV2) common (COM2) and 4268A's internal circuit common are not connected. The operation output signals and input signals are isolated.	Short
P18 2-3	External power supply's (EXT DCV2) common (COM2) and 4268A's internal circuit common are connected. The operation output signals and input signals are not isolated.	Open
P19 1-2	External power supply's (EXT DCV1) common (COM1) and 4268A's internal circuit common are not connected. The judgment output signals are isolated.	Short
P19 2-3	External power supply's (EXT DCV1) common (COM1) and 4268A's internal circuit common are connected. The judgment output signals are not isolated.	Open

NOTE: When using +5 V (pins 16, 17, and 18) of the handler interface connector, set (short) 2-3 of P18 or 2-3 of P19 to connect 4268A's internal circuit common and COM1 or COM2 so that COM1 or COM2 is used as the power supply circuit common.

Setting the switch (S2)

Each switch of the switch (S2) must be set as follows, depending on the voltage setting of the operation output signal pull-up and input signal drive power supply (DCV2).

Voltage setting of the operation output signal pull-up and input signal drive power supply (DCV2)

5 V ≤ DCV2 ≤ 6

6 V < DCV2 ≤ 9 V

9 V < DCV2 ≤ 15

(factory setting)



Setting the pull-up resistors

The pull-up resistors for the operation output signals and judgment output signals must be set using J12 and J13 on the A1 main board. The following table shows the location where the resistor for

each signal should be mounted, the equation to calculate the pull-up resistor values, and the typical resistance values. For information on the location of J12 and J13 and the location of the resistors for J12 and J13, refer to Figure 12.

Signal Name	Resistor location	Resistance value [kΩ]	Typical resistance value [kΩ]				
			DCV1 or DCV2 voltage				
			5 V	9 V	12 V	15 V	24 V
/OUT_OF_BINS	R1-1	DCV1/3	1.78	3.16	4.22	5.11	8.25
/BIN1	R1-2	DCV1/3	1.78	3.16	4.22	5.11	8.25
/BIN2	R1-3	DCV1/3	1.78	3.16	4.22	5.11	8.25
:	:	:	:	:	:	:	:
/BIN8	R1-9	DCV1/3	1.78	3.16	4.22	5.11	8.25
/BIN9	R1-10	DCV1/3	1.78	3.16	4.22	5.11	8.25
/AUX_BIN	R1-11	DCV1/3	1.78	3.16	4.22	5.11	8.25
/PHI	R2-1	DCV1/3	1.78	3.16	4.22	5.11	8.25
/PLO	R2-2	DCV1/3	1.78	3.16	4.22	5.11	8.25
/SREJ	R2-3	DCV1/3	1.78	3.16	4.22	5.11	8.25
(reserved)	R2-4	—	—	—	—	—	—
/NO_CONTACT	R2-5	DCV1/3	1.78	3.16	4.22	5.11	8.25
/OVLD	R2-6	DCV1/3	1.78	3.16	4.22	5.11	8.25
(reserved)	R2-7	—	—	—	—	—	—
(reserved)	R2-8	—	—	—	—	—	—
/ALARM	R2-9	DCV2/3	1.78	3.16	4.22	5.11	—
/INDEX	R2-10	DCV2/3	1.78	3.16	4.22	5.11	—
/EOM	R2-11	DCV2/3	1.78	3.16	4.22	5.11	—

The product numbers of the resistors are as follows:
 1.78 kΩ 0757-0278
 3.16 kΩ 0757-0279
 4.22 kΩ 0698-3154
 5.11 kΩ 0757-0438
 8.25 kΩ 0757-0441

The resistors are not factory-mounted. R2-4, R2-7, and R2-8 are reserved. Do not connect anything.

Procedure to remove the cover

This section describes how to disconnect the cables that hinder the operator from removing and attaching the cover when setting the drive/pull-up power supply or mounting pull-up resistors.

WARNING: Perform this work when 10 minutes or more have elapsed after disconnecting the power cord. When the 4268A is operating, or immediately after the power is turned off, dangerous electrical energy or voltage exists. Therefore, sufficient time is required after disconnecting the power cord to discharge the internal capacitor.

NOTE: When removing the cover, setting the drive/pull-up power supply, and mounting pull-up resistors, perform the work in a place with static protection, wearing a ground strap.

Step 1. Disconnect Agilent 4268A's power cord and wait for 10 minutes.

Step 2. Remove the two screws that secure the cover on the rear panel of the chassis.

Step 3. While holding the front panel bezel, slide the cover backward to remove it.

Step 4. Disconnect the cable connected to the A2 CPU board from the GPIB connector on the rear panel.

Step 5. If the scanner interface (option) is installed, disconnect the cable connected to the A1 main-board from the scanner interface connector on the rear panel.

NOTE: When mounting pull-up resistors, exercise care not to damage surrounding parts (including cables and connectors) with a soldering iron or otherwise.

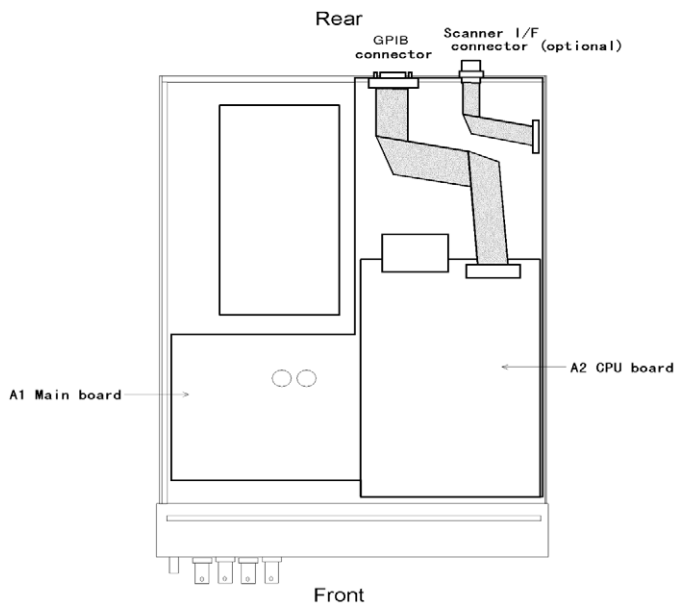

Agilent Technologies' Test and Measurement Support, Services, and Assistance

Agilent Technologies aims to maximize the value you receive, while minimizing your risk and problems. We strive to ensure that you get the test and measurement capabilities you paid for and obtain the support you need. Our extensive support resources and services can help you choose the right Agilent products for your applications and apply them successfully. Every instrument and system we sell has a global warranty. Support is available for at least five years beyond the production life of the product. Two concepts underlie Agilent's overall support policy: "Our Promise" and "Your Advantage."

Our Promise

Our Promise means your Agilent test and measurement equipment will meet its advertised performance and functionality. When you are choosing new equipment, we will help you with product information, including realistic performance specifications and practical recommendations from experienced test engineers. When you use Agilent equipment, we can verify that it works properly, help with product operation, and provide basic measurement assistance for the use of specified capabilities, at no extra cost upon request. Many self-help tools are available.

Your Advantage

Your Advantage means that Agilent offers a wide range of additional expert test and measurement services, which you can purchase according to your unique technical and business needs. Solve problems efficiently and gain a competitive edge by contracting with us for calibration, extra-cost upgrades, out-of-warranty repairs, and onsite education and training, as well as design, system integration, project management, and other professional engineering services. Experienced Agilent engineers and technicians worldwide can help you maximize your productivity, optimize the return on investment of your Agilent instruments and systems, and obtain dependable measurement accuracy for the life of those products.

Agilent T&M Software and Connectivity

Agilent's Test and Measurement software and connectivity products, solutions and developer network allows you to take time out of connecting your instruments to your computer with tools based on PC standards, so you can focus on your tasks, not on your connections. Visit

www.agilent.com/find/connectivity

for more information.



Agilent Email Updates

www.agilent.com/find/emailupdates

Get the latest information on the products and applications you select.

By internet, phone, or fax, get assistance with all your test & measurement needs

Phone or Fax

United States:
(tel) 800 452 4844

Canada:
(tel) 877 894 4414
(fax) 905 282 6495

China:
(tel) 800 810 0189
(fax) 800 820 2816

Europe:
(tel) (31 20) 547 2323
(fax) (31 20) 547 2390

Japan:
(tel) (81) 426 56 7832
(fax) (81) 426 56 7840

Korea:

(tel) (82 2) 2004 5004
(fax) (82 2) 2004 5115

Latin America:

(tel) (305) 269 7500
(fax) (305) 269 7599

Taiwan:

(tel) 0800 047 866
(fax) 0800 286 331

Other Asia Pacific Countries:

(tel) (65) 6375 8100
(fax) (65) 6836 0252

Email:
tm_asia@agilent.com

Online Assistance:

www.agilent.com/find/assist

Product specifications and descriptions in this document subject to change without notice.

© 2003 Agilent Technologies, Inc.

Printed in USA, April 28, 2003

5968-3970E



Agilent Technologies