

Agilent

4396B 1.8 GHz

Network/Spectrum/Impedance Analyzer

Data Sheet

Specifications describe the instrument's warranted performance over the temperature range of 0 °C to 40 °C (except as noted). Supplemental characteristics are intended to provide information that is useful in applying the instrument by giving non-warranted performance parameters. These are denoted as *typical*, *typically*, *nominal*, or *approximate*. Warm-up time must be greater than or equal to 30 minutes after power on for all specifications.

Network Measurement

Source characteristics

Frequency characteristics (Option 4396B-800)

Range 100 kHz to 1.8 GHz

Resolution ≤ 1 mHz

Frequency reference

Accuracy

23 ± 5 °C, referenced to 23 °C $< \pm 5.5$ ppm/year

Aging $< \pm 2.5$ ppm/year typically

Initial achievable accuracy $< \pm 1.0$ ppm typically

Temperature stability

23 ± 5 °C, referenced to 23 °C $< \pm 2$ ppm typically

Precision frequency reference (Option 4396B-1D5)

Accuracy

0 °C to 40 °C, referenced to 23 °C $< \pm 0.13$ ppm/year

Aging $< \pm 0.1$ ppm/year typically

Initial achievable accuracy $< \pm 0.02$ ppm typically

Temperature stability

0 °C to 40 °C, referenced to 23 °C $< \pm 0.01$ ppm typically



Output Characteristics

- Power range**-60 dBm to +20 dBm
- Power sweep range**20 dB
- Power sweep linearity**
 - 23 ±5 °C, 50 MHz, relative to stop power ±0.5 dB
- Resolution**0.1 dB
- Flatness**
 - 23 ±5 °C, relative to 50 MHz, 0 dBm output ±1.0 dB
- Level accuracy**
 - 23 ±5 °C, 50 MHz, 0 dBm output < ± 0.5 dB

Level linearity

Output power	Linearity¹
-20 dBm ≤ power ≤ +20 dBm	±0.7 dB
-40 dBm ≤ power < -20 dBm	±1.0 dB
-60 dBm ≤ power < -40 dBm	±1.5 dB

Spectral purity characteristics

- Harmonics**
 - +15 dBm output< -30 dBc
- Non-harmonics spurious**
 - +15 dBm output< -30 dBc
- Noise sidebands**
 - SPAN = 0, IFBW (or RBW) ≤ 3 kHz
 - frequency ≤ 1 GHz
 - ≥ 10 kHz offset from carrier< -105 dBc/Hz typically
 - ≥ 1 MHz offset from carrier< -110 dBc/Hz typically
 - frequency > 1 GHz Add [20 log(*frequency(GHz)*)] typically
- Impedance** 50 Ω nominal
- Return loss**
 - ≤ 0 dBm, 100 MHz < frequency ≤ 1.8 GHz> 14 dB typically
 - ≤ 0 dBm, 100 kHz ≤ frequency ≤ 100 MHz> 23 dB typically
- Connector**Type-N female

1. At 23 ±5 °C, relative to 0 dBm output

Receiver Characteristics

Input characteristics

Frequency range

IFBW \leq 3 kHz 100 kHz to 1.8 GHz

IFBW = 10 kHz, 40 kHz 1 MHz to 1.8 GHz

Full scale input level

R input +20 dBm

A, B inputs -5 dBm

IF bandwidth (IFBW) 10, 30, 100, 300, 1 k, 3 k, 10 k, 40 kHz

Noise level

Frequency	Input port	Noise level IFBW = 10 Hz	Noise level IFBW = 40 kHz
100 k \leq freq. < 10 MHz	R	< -85 dBm	< -50 dBm
100 k \leq freq. < 10 MHz	A, B	< -110 dBm	< -75 dBm
10 MHz \leq freq.	R	< [-100 + 3 <i>f</i>] dBm ¹	< [-65 + 3 <i>f</i>] dBm ¹
10 MHz \leq freq.	A, B	< [-125 + 3 <i>f</i>] dBm ¹	< [-90 + 3 <i>f</i>] dBm ¹

Input crosstalk

\geq 300 kHz

A to/from B < -100 dB

R to A, B < -120 dB

A, B to R < -80 dB

Source crosstalk (A, B)

\geq 300 kHz < -124 dB typically

Maximum safe input level +20 dBm or \pm 25 Vdc typically

Connector Type-N female

Impedance 50 Ω nominal

Return loss

frequency \geq 500 kHz > 20 dB

100 kHz \leq frequency < 500 kHz > 12 dB typically

3 MHz \leq frequency \leq 50 MHz > 35 dB typically

Multiplexer switching impedance change < 1 Ω typically

1. *f* is measurement frequency (GHz).

Magnitude Characteristics

Absolute amplitude accuracy (R, A, B)

-20 dBm input, 23 ±5 °C < ±1.5 dB (±0.9 dB typically)

Ratio accuracy (A/R, B/R)

-20 dBm input, 23 ±5 °C, IFBW ≤ 3 kHz

100 k ≤ frequency < 1 MHz < ±1 dB (±0.6 dB typically)

frequency ≥ 1 MHz < ±0.5 dB (±0.3 dB typically)

Dynamic accuracy (A/R, B/R)

Input level

(relative to full scale input level)¹

Dynamic accuracy²

0 dB	< ±0.3 dB
-10 dB to -70 dB	< ±0.05 dB
-80 dB	< ±0.1 dB
-90 dB	< ±0.3 dB
-100 dB	< ±1.0 dB
-110 dB	< ±0.8 dB typically
-120 dB	< ±2.5 dB typically

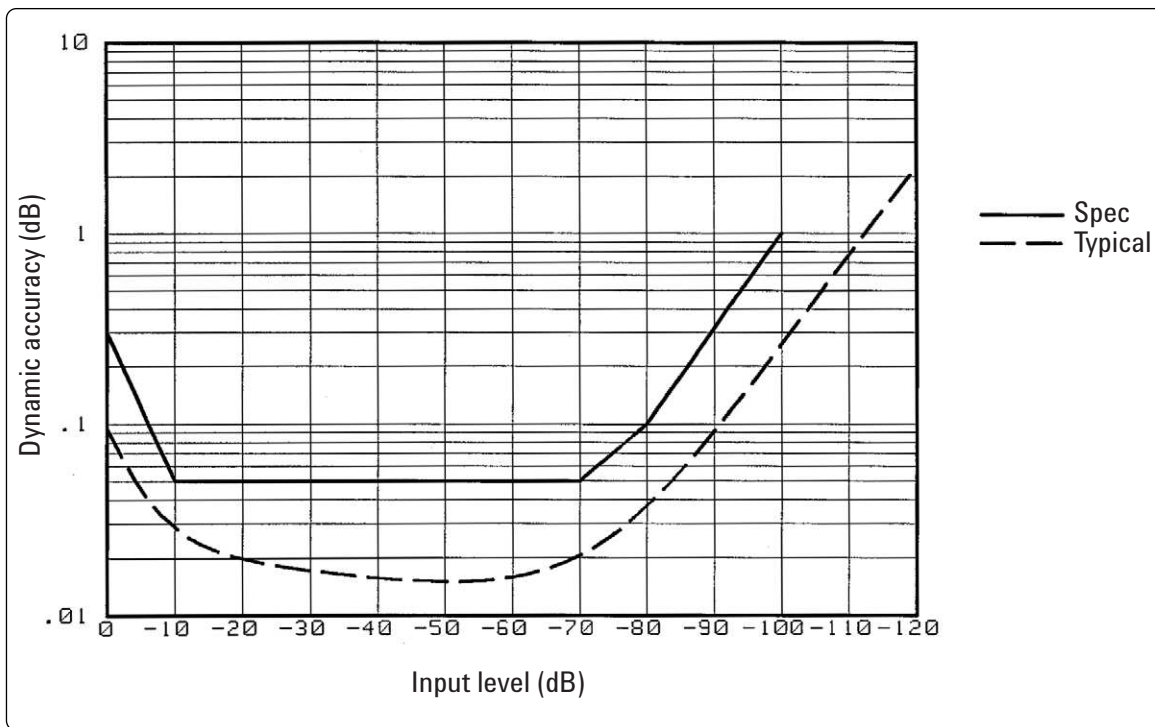

Figure 1. Magnitude dynamic accuracy

Residual responses

A, B inputs, frequency ≥ 3 MHz < -95 dBm typically

R input, frequency ≥ 3 MHz < -70 dBm typically

See “EMC” under “Others” in “Common Specifications for Network and Spectrum Measurement.”

Trace noise

A/R, B/R measurement,

-10 dBm input, IFBW = 300 Hz < 0.002 dB rms typically

Stability 0.01 dB/°C typically

1. Full scale input level = -5 dBm

2. At 23 ±5 °C, IFBW = 10Hz, R input = -35 dBm, Reference power level = -35 dBm

Phase Characteristics

Measurements formatPhase format, expanded phase format

Frequency response (deviation from linear phase) (A/R, B/R)

-20 dBm input, 23 ±5 °C, IFBW ≤ 3 kHz

100 k ≤ frequency < 1 MHz< ±6 deg (±4 deg typically)

frequency ≥ 1 MHz < ±3 deg (±2 deg typically)

Dynamic accuracy (A/R, B/R)

Input level (relative to full scale input level) ¹	Dynamic accuracy ²
0 dB	< ±3 deg
-10 dB	< ±0.6 deg
-20 dB to -70 dB	< ±0.3 deg
-80 dB	< ±0.7 deg
-90 dB	< ±2.3 deg
-100 dB	< ±7 deg
-110 dB	< ±8 deg typically
-120 dB	< ±25 deg typically

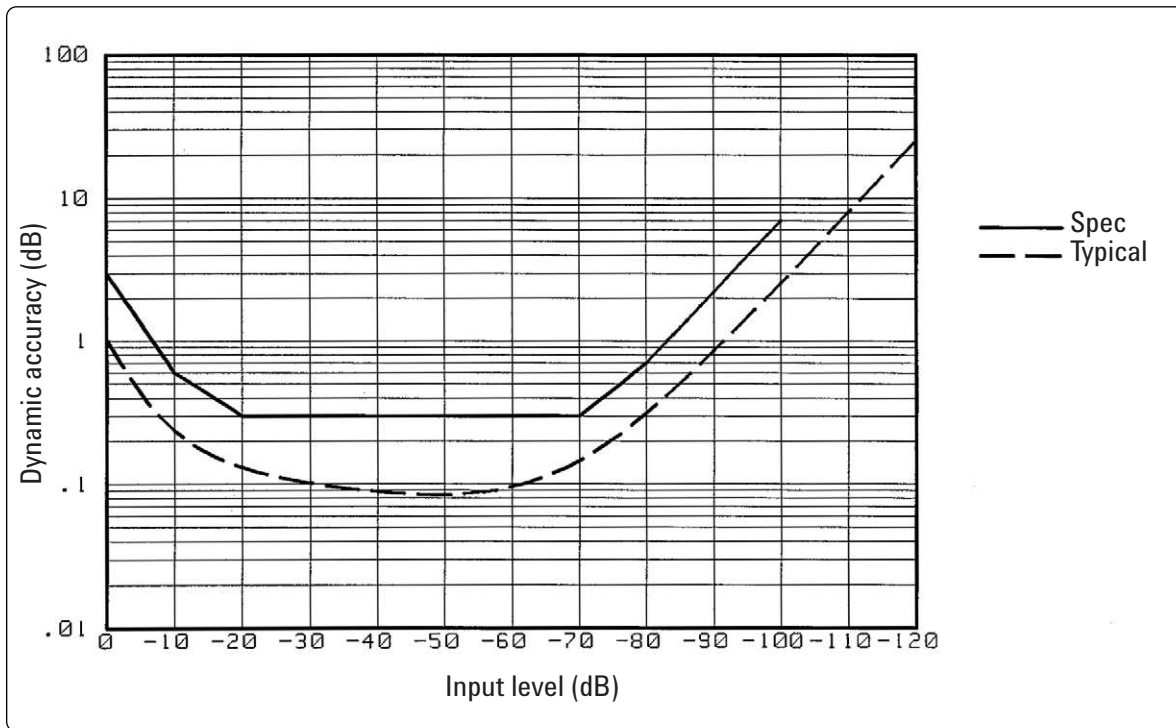

Figure 2. Phase dynamic accuracy

Trace noise

A/R, B/R measurement,

-10 dBm input, IFBW = 300 Hz< 0.04 deg rms typically

Stability 0.1 deg/°C typically

1. Full scale input level = -5 dBm
 2. At 23 ±5 °C, IFBW = 10 Hz, R input = -35 dBm, Reference power level = -35 dBm

Group Delay Characteristics

Accuracy

In general, the following formula can be used to determine the accuracy, in seconds, of a specific group delay measurement:

$$23 \pm 5 \text{ } ^\circ\text{C} \dots\dots\dots \frac{\text{phaseAccuracy(deg)}}{\text{Aperture(Hz)} \times 360 \text{ deg}}$$

Depending on the aperture, input level, and device length, the phase accuracy used in either incremental phase accuracy or worst case phase accuracy.

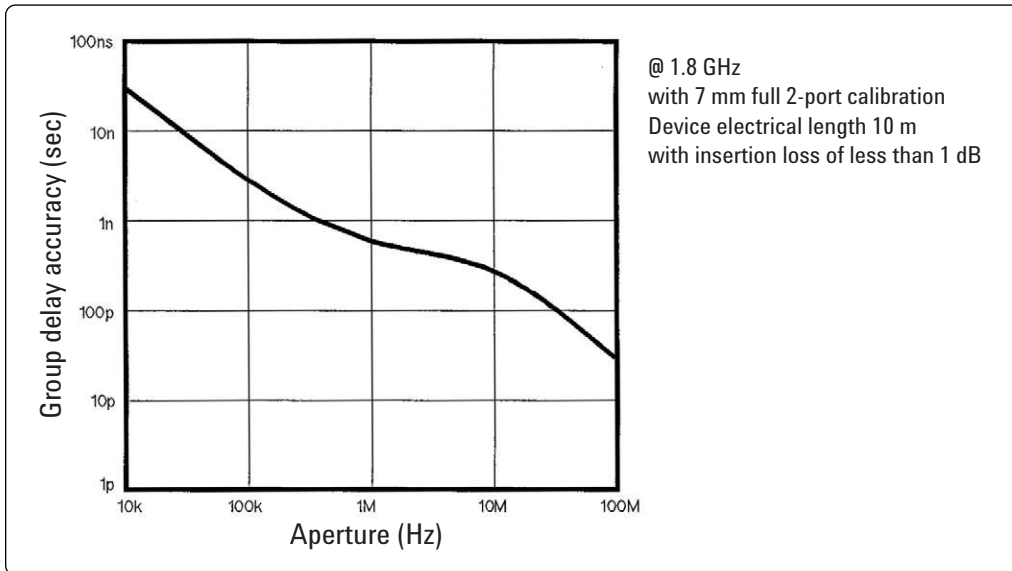

Figure 3. Typical group delay accuracy

Sweep Characteristics

- Sweep type**Linear frequency, log frequency, power, list frequency
- Trigger type**Hold, single, number of groups, continuous
- Trigger source**Free run, external, manual, GPIB (bus)
- Event trigger**On point, On sweep

Spectrum Measurement

Specifications in this section describe the instrument's warranted performance for spectrum measurement using S input (except as noted).

Frequency Characteristics

Frequency range 2 Hz to 1.8 GHz

Frequency readout accuracy

..... $\pm((freq\ readout) \times (freq\ ref\ accuracy) + RBW + \frac{SPAN}{NOP})$

where NOP means number of display points

Frequency reference (Option 4396B-800)

Accuracy

23 ±5 °C, referenced to 23 °C < ±5.5 ppm/year

Aging < ±2.5 ppm/year typically

Initial achievable accuracy < ±1 ppm typically

Temperature stability

23 ±5 °C, referenced to 23 °C < ±2 ppm typically

Precision frequency reference (Option 4396B-1D5)

Accuracy

0 °C to 40 °C, referenced to 23 °C < ±0.13 ppm/year

Aging < ±0.1 ppm/year typically

Initial achievable accuracy < ±0.02 ppm typically

Temperature stability

0 °C to 40 °C, referenced to 23 °C < ±0.01 ppm typically

Resolution bandwidth (RBW)

Range 1 Hz to 3 MHz, 1-3-10 step

Selectivity (60 dB BW/3 dB BW)

RBW ≥ 10 kHz < 10

RBW ≤ 3 kHz < 3

Accuracy

RBW ≥ 10 kHz < ±20%

RBW ≤ 3 kHz < ±10%

Video bandwidth

Range 0.003 Hz to 3 MHz, 1-3-10 step, $1 \leq RBW/VBW \leq 300$

Noise sidebands

Offset from carrier	Noise sidebands ¹
≥ 1 kHz	< -95 dBc/Hz
≥ 10 kHz	< -105 dBc/Hz
≥ 1 MHz	< -110 dBc/Hz

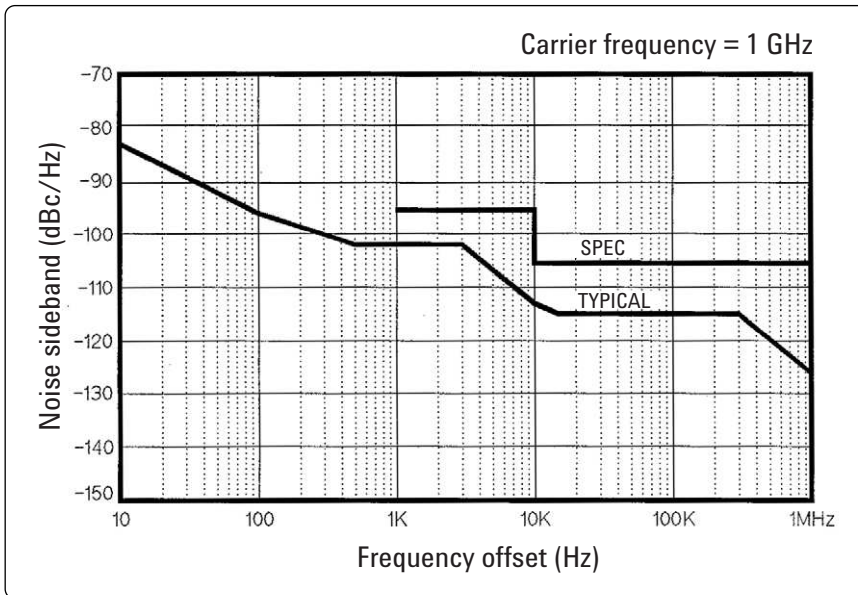

Figure 4. typical noise sidebands (with Option 4396B-1D5)

Residual FM

RBW ≤ 10 Hz

Option 4396B-800 < 1 × f (GHz) Hz_{pk-pk} in 10 sec typically

Frequency = 1 GHz < 1 Hz_{pk-pk} typically

Option 4396B-1D5 < 0.1 × f (GHz) Hz_{pk-pk} in 10 sec typically

Frequency = 1 GHz < 0.1 Hz_{pk-pk} typically

RBW ≤ 1 kHz < 3 Hz_{pk-pk} in 100 msec typically

1. Center frequency ≤ 1 GHz. Add [20log(frequency(GHz))] for frequency > 1 GHz.

On-screen dynamic range

1 GHz center frequency, may be limited by average noise level.

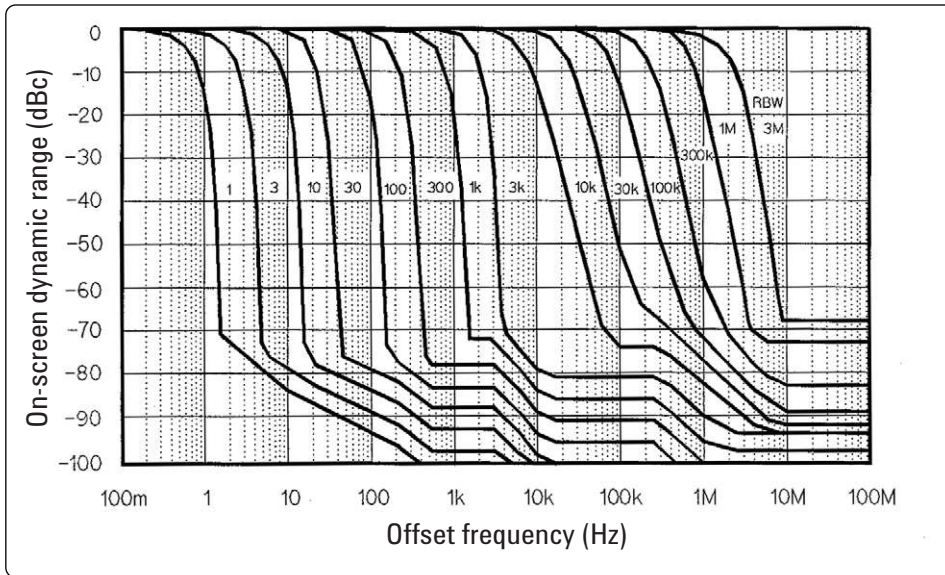

Figure 5. Typical on-screen dynamic range

Amplitude characteristics

Amplitude rangeDisplayed average noise level to +30 dBm

Reference level range-100 dBm to +30 dBm
(or equivalent in dBμV, dBV, V, W)

Scale

Log0.1 dB/div to 20 dB/div

Linear

Watt 1.0×10^{-12} W/div

Volt 1.0×10^{-9} V/div

Measurement formatSPECTRUM or NOISE (/HZ)

Display unitdBm, dBμV, dBV, Volts, Watts

Typical Dynamic Range

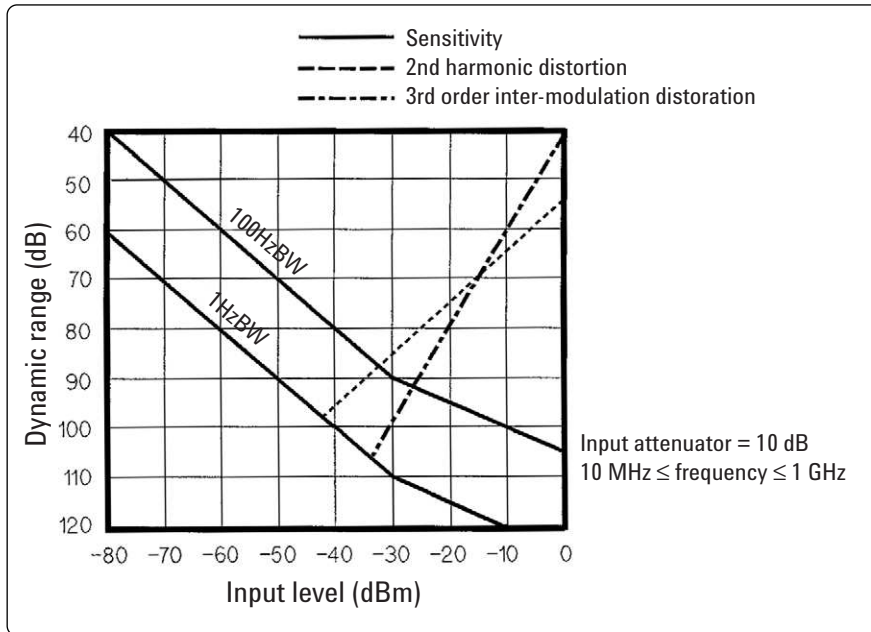

Figure 6. Typical dynamic range at S input

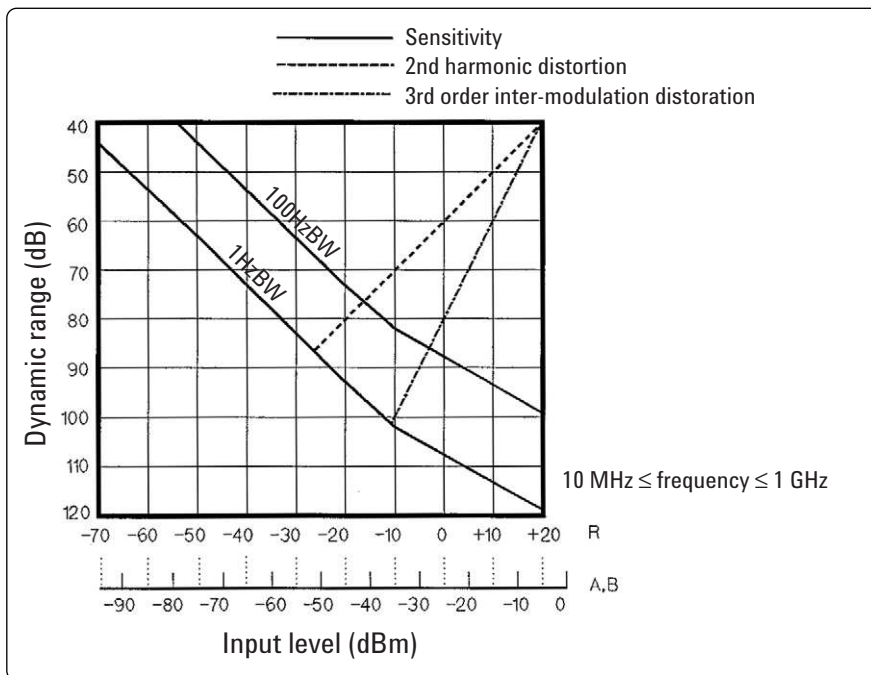

Figure 7. Typical dynamic range at R, A, and B inputs

Spurious responses

Second harmonic distortion

- ≥ 10 MHz, -35 dBm mixer input < -70 dBc
- < 10 MHz, -35 dBm mixer input < -60 dBc

Third order intermodulation distortion

- each input mixer level of two tones = -30 dBm, separation ≥ 20 kHz
- ≥ 10 MHz < -75 dBc
- < 10 MHz < -65 dBc

Other spurious

- 30 dBm mixer input, offset ≥ 1 kHz < -70 dBc

Residual response

- ≥ 3 MHz, 0 dB attenuator < -100 dBm
- 1 kHz ≤ frequency < 3 MHz, 0 dB attenuator < -90 dBm
- See “EMC” under “Others” in “Common Specifications for Network
and Spectrum Measurement.”

Local oscillator feedthrough . . . < -25 dBm input mixer level equivalent typically

Gain compression

- ≥ 10 MHz, input mixer level < -10 dBm < 0.3 dB typically

Displayed average noise level

- frequency ≥ 10 MHz,
ref. level ≤ -40 dBm, att. = 0 dB < [-150 + 3f (GHz)] dBm/Hz
- 10 kHz ≤ frequency < 10 MHz,
ref. level ≤ -40 dBm, att. = 0 dB < -125 dBm/Hz

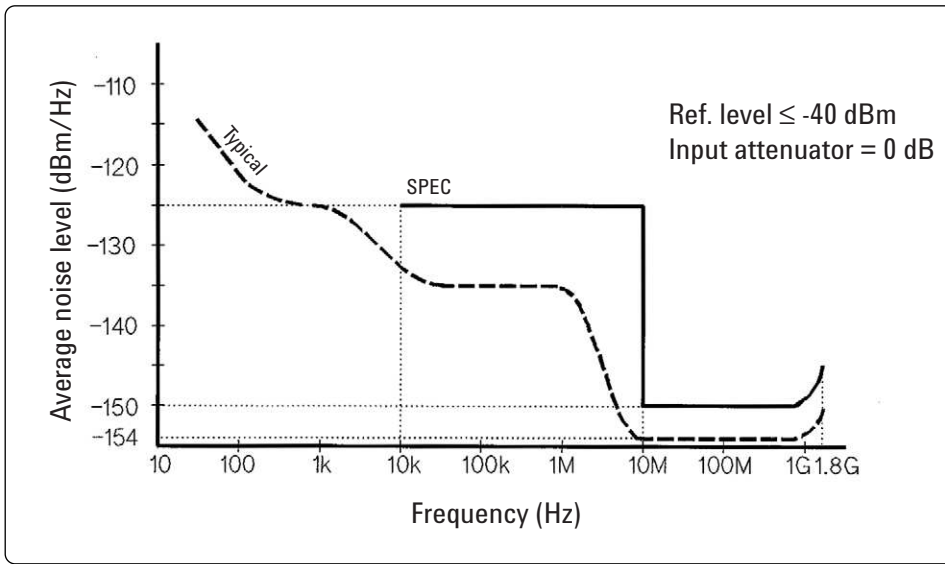

Figure 8. Typical displayed average noise level

Maximum safe input level

- Average continuous power** +30 dBm (1 W)

Peak pulse power

- Pulse width < 10 μs,
duty cycle < 1%, input attenuator ≥ 30 dB +50 dBm (100 W)

- dc voltage** 0 Vdc

Input attenuator

- Range** 0 dB to 60 dB, 10 dB step

Level accuracy

- Calibrator accuracy** (-20 dBm 20 MHz) < ±0.4 dB (±0.2 dB typically)

Frequency response

2 ±5 °C, aft. = 10 dB, referenced to level at 20 MHz

10 MHz ≤ frequency ≤ 1.8 GHz < ±0.5 dB (±0.3 dB typically)

2 Hz ≤ frequency < 10 MHz < ±1.5 dB (±0.8 dB typically)

Amplitude fidelity

Log scale

Range (dB from ref. level)	Amplitude fidelity @ 1 Hz ≤ RBW ≤ 3 kHz		Amplitude fidelity ¹ @ 10 kHz ≤ RBW ≤ 300 kHz		Amplitude fidelity ¹ @ 1 MHz ≤ RBW ≤ 3 MHz	
	Spec.	Typical	Spec.	Typical	Spec.	Typical
0 dB ≥ range ≥ -30 dB	±0.05 dB	±0.02 dB	±0.3 dB	±0.12 dB	±1.0 dB	±0.4 dB
-30 dB > range ≥ -40 dB	±0.07 dB	±0.03 dB	±0.3 dB	±0.12 dB	±1.0 dB	±0.4 dB
-40 dB > range ≥ -50 dB	±0.12 dB	±0.05 dB	±0.4 dB	±0.15 dB	±1.2 dB	±0.5 dB
-50 dB > range ≥ -60 dB	±0.4 dB	±0.12 dB	±0.7 dB	±0.3 dB	±1.4 dB	±0.6 dB
-60 dB > range ≥ -10 dB	±1.2 dB	±0.8 dB	±1.5 dB	±0.6 dB	±2.2 dB	±0.8 dB
-10 dB > range ≥ -80 dB	±4 dB	±1 dB	±4.3 dB	±1.2 dB	-	-
-80 dB > range ≥ -90 dB	-	+3 dB	-	-	-	-
-90 dB > range ≥ -100 dB	-	±10 dB	-	-	-	-

For small signal measurement, fidelity is degraded by noise floor according to below formula:

$$20 \log_{10} (1 \pm 10^{\frac{x}{20}} \times 3.5) \text{ dB typically}$$

where x is signal to noise floor ratio in dB.

This fidelity error can be reduced by narrower video bandwidth or sweep averaging.

Linear scale

23 ±5 °C, -10 dBm ≥ [*ref level - input att*] ≥ -50 dBm except for gain compression

RBW ≤ 300 kHz < ±3% of reference level

RBW ≥ 1 MHz < ±10% of reference level

IF gain switching uncertainty

input att. fixed, referenced to -20 dBm [*ref. level - input acct*] . . . < ±0.3 dB

Input attenuator switching uncertainty

20 dB to 40 dB, referenced to 10 dB < ±1.0 dB

50 dB to 60 dB, referenced to 10 dB < ±1.5 dB

RBW switching uncertainty

SPAN < 100 x RBW for RBW ≥ 10 kHz,

23 ±5 °C, referenced to 10 kHz RBW < ±0.5 dB

Temperature drift

S input 0.05 dB/°C typically

R, A, B inputs 0.1 dB/°C typically

1. At 23 ±5 °C, 10 dBm ≥ [*ref. level input att*] > -50 dBm except for gain compression

Sweep characteristics

Sweep type Linear, zero span, list
Trigger type Hold, single, number of groups, continuous
Trigger source Free run, external, video, manual, gate

Sweep time

RBW	SPAN	Typical sweep time
3 MHz	1.8 GHz	40 ms
1 MHz	1 GHz	60 ms
300 kHz	1 GHz	340 ms
100 kHz	100 MHz	100 ms
30 kHz	100 MHz	460 ms
10 kHz	10 MHz	400 ms
3 kHz	10 MHz	2.4 s
1 kHz	1 MHz	651 ms
300 Hz	1 MHz	3 s
100 Hz	100 kHz	1.4 s
30 Hz	100 kHz	3.2 s
10 Hz	10 kHz	1.5 s
3 Hz	10 kHz	12 s
1 Hz	1 kHz	11 s
–	Zero Span	– ¹

Zero span

Normal zero span $\geq 25 \mu\text{s}/\text{display point}$

Repetitive zero span $\geq 0.5 \mu\text{s}/\text{display point}$

Number of display points

span \neq zero

RBW ≥ 10 kHz

Sweep time = auto 801 points (fixed)

Sweep time = manual ≤ 801 points (automatically set)

RBW ≤ 3 kHz ≤ 801 points (automatically set)

span = zero 2 to 801 points (selectable)

1. See the next item for sweep time at zero span.

Input and Output Characteristics

RF input

ConnectorType-N female

Impedance50 Ω nominal

Return Loss

S input

> 50 MHz, input att. \geq 10 dB> 14 dB typically

\leq 50 MHz, input att. \geq 10 dB> 25 dB typically

R, A, B inputs same as network measurement

Coupling

S inputDC

R, A, B inputsAC

Crosstalk

S Input, input att = 10 dB

S input to A, B inputs< -30 dB typically

A, B inputs to S input< -22 dB typically

Cal output

ConnectorBNC female

Impedance50 Ω

Output frequency20 MHz

Output level-20 dBm \pm 0.4 dB

Return loss> 26 dB typically

Specifications when Option 4396B-1D6 time-gated spectrum analysis is installed

Gate length

Range 0.2 μ s to 3.2 s

Resolution

Range of gate length (T_g)	Resolution
$2 \mu\text{s} \leq T_g \leq 32 \text{ ms}$	0.5 μ s
$32 \text{ ms} < T_g \leq 64 \text{ ms}$	1 μ s
$64 \text{ ms} < T_g \leq 160 \text{ ms}$	2.5 μ s
$160 \text{ ms} < T_g \leq 320 \text{ ms}$	5 μ s
$320 \text{ ms} < T_g \leq 1.28 \text{ s}$	20 μ s
$1.28 \text{ ms} < T_g \leq 3.2 \text{ s}$	100 μ s

Gate delay

Range 0.2 μ s to 3.2 s

Resolution

Range of gate delay (T_d)	Resolution
$2 \mu\text{s} \leq T_d \leq 32 \text{ ms}$	0.5 μ s
$32 \text{ ms} < T_d \leq 64 \text{ ms}$	1 μ s
$64 \text{ ms} < T_d \leq 160 \text{ ms}$	2.5 μ s
$160 \text{ ms} < T_d \leq 320 \text{ ms}$	5 μ s
$320 \text{ ms} < T_d \leq 1.28 \text{ s}$	20 μ s
$1.28 \text{ ms} < T_d \leq 3.2 \text{ s}$	100 μ s

Additional amplitude error

Log scale < 0.3 dB typically

Linear scale < 3% typically

Gate control modes Edge pos, Edge neg, or level

Gate trigger input (external trigger input is used)

Connector BNC female

Trigger level TTL

Gate output

Connector BNC female

Output level TTL

Specifications with Option 4396B-1D7 50 Ω to 75 Ω input impedance conversion

All specifications are identical to the standard 4396B except the following items.

Amplitude range Displayed average noise level to 24 dBm

Displayed average noise level

$\geq 10 \text{ MHz}$ < $[-148 + 3f (GHz)]$ dBm/Hz typically

Level accuracy

20 MHz, after level cal < ± 0.4 dB typically

Frequency response

input attenuator = 10 dB < ± 0.5 dB typically

Impedance Measurement (Option 4396B-010)

Measurement functions

Measurement parameters Z, Y, L, C, Q, R, X, G, B, θ

Display parameters [Z], θ_z , R, X, [Y], θ_y , G, B,
[Γ], θ_g , Γ_x , Γ_y , Cp, Cs, Lp, Ls, Rp, Rs, D, Q

Display formats

- Vertical lin/log scale
- Complex plane
- Polar/Smith/admittance chart

Sweep parameters

- Linear frequency sweep
- Logarithmic frequency sweep
- List frequency sweep
- Linear power sweep (dBm)

IF bandwidth

- 10, 30, 100, 300, 1 k, 3 k, 10 k, 40 k [Hz]

Calibration

- OPEN/SHORT/LOAD 3 term calibration
- Fixture compensation
- Port extension correction

Unknown port

- 7-mm connector

Output characteristics¹

Frequency range 100 kHz to 1.8 GHz

Frequency resolution 1 mHz

Output level -60 to +20 dBm (@RF OUT port)

Output level accuracy A + B + 6 [dB] x F/(1.8 x 10⁹)

Where,

A = 2 dB (± 5 °C)

B = 0 dB (GSC \leq 0 dBm), or 1 dB ($-40 \leq$ GSC < 0 dBm),

or 2 dB ($-60 \leq$ GSC < -40 dBm)

F is output frequency.

Output level resolution 0.1 dB

Measurement port impedance Nominal 50 Ω

1. Signal level at the measurement port is 6 dB lower than the RF GUT port when the measurement port is terminated by 50 Ω .

External DC bias input¹

Maximum voltage±40 V
Maximum current20 mA

Measurement Basic Accuracy (Supplemental Performance Characteristics)

Measurement accuracy is specified at the connecting surface of the 7-mm connector of the 43961A under the following conditions:

Warm-up time> 30 minutes
Ambient temperature23 °C ±5 °C
(at the same temperature at which calibration was performed)
Signal level (@50 Ω terminated) -6 to 14 dBm
CorrectionON
IFBW≤ 300 Hz
Averaging (cal)≥ 8

1. 2 kΩ ±5% resistor is inserted for DC bias current limitation.

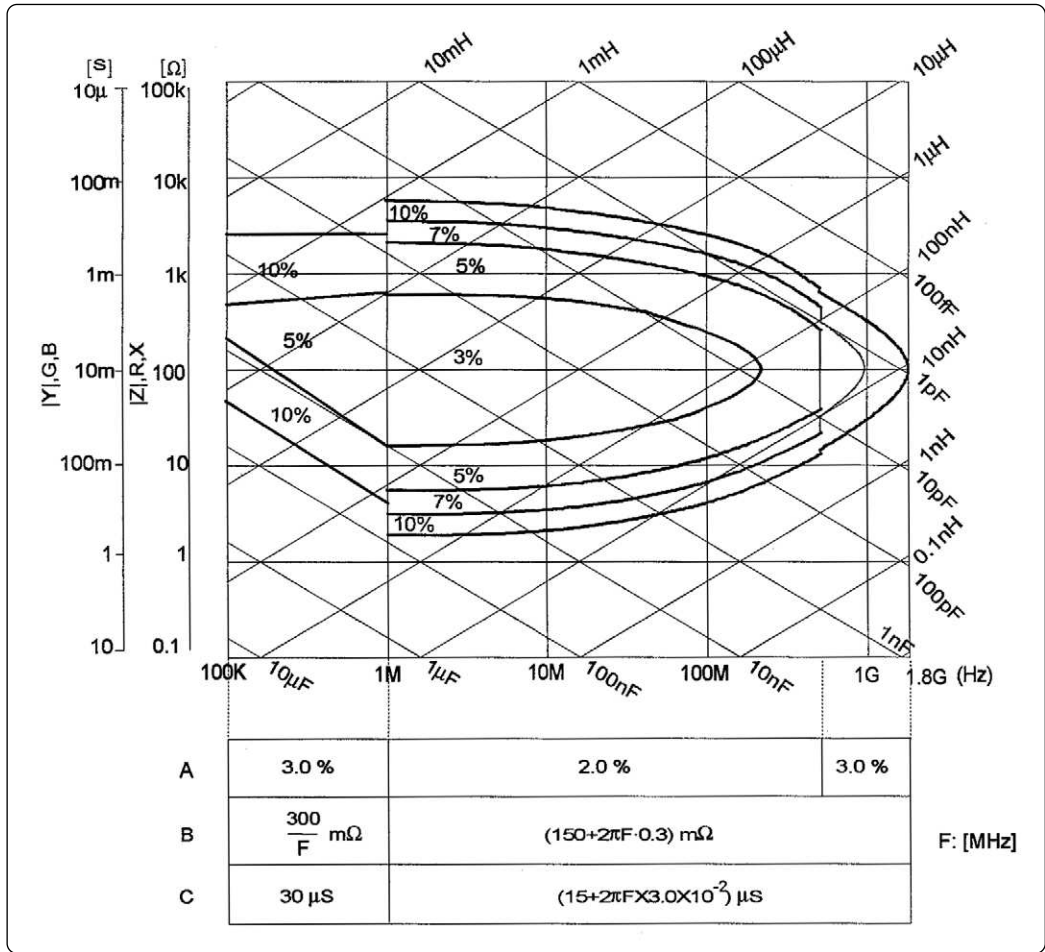

Figure 9. Impedance measurement accuracy

$|Z| - \theta$ accuracy

$$|Z| \text{ accuracy} \quad Z_a = A + (B/|Z_m| + C \times |Z_m|) \times 100[\%]$$

$$\theta \text{ accuracy} \quad \theta_a = \sin^{-1}(Z_a/100)$$

Where, is $|Z_m|$ is $|Z|$ measured. A, B, and C are obtained from Figure 9.

YI – θ accuracy

$$\begin{aligned} \text{YI accuracy} & Y_a = A + (B \times |Y_m| + C/|Y_m|) \times 100[\%] \\ \theta \text{ accuracy} & \theta_a = \sin^{-1}(Y_a/100) \end{aligned}$$

Where, $|Y_m|$ is YI measured. A, B, and C are obtained from Figure 9.

R – X accuracy (depends on D)

Accuracy	$D \leq 0.2$	$0.2 < D \leq 5$	$5 < D$
R_a	$\pm X_m \times X_a/100[\Omega]$	$R_a/\cos\theta$ [%]	R_a [%]
X_a	X_a [%]	$X_a/\sin\theta$ [%]	$\pm R_m \times X_a/100[\Omega]$

Where,

$$\begin{aligned} D \text{ can be calculated as: } & R/X, \text{ or} \\ & R/(2\pi f \times L_s), \text{ or} \\ & R \times 2\pi f \times C_s \end{aligned}$$

$$\begin{aligned} \theta \text{ can be calculated as: } & \tan^{-1}(X/R), \text{ or} \\ & \tan^{-1}(2\pi f \times L_s/R), \text{ or} \\ & \tan^{-1}(1/(R \times 2\pi f \times C_s)) \end{aligned}$$

$$R_a = A + (B/|R_m| + C \times |R_m|) \times 100 [\%]$$

$$X_a = A + (B/|X_m| + C \times |X_m|) \times 100 [\%]$$

R_m and X_m are the measured R and X, respectively. A, B, and C are obtained from Figure 9.

G – B accuracy (depends on D)

Accuracy	$D \leq 0.2$	$0.2 < D \leq 5$	$5 < D$
G_a	$\pm B_m \times B_a/100[S]$	$G_a/\cos\theta$ [%]	G_a [%]
B_a	B_a [%]	$B_a/\sin\theta$ [%]	$\pm G_m \times B_a/100[S]$

Where,

$$\begin{aligned} D \text{ can be calculated as: } & G/B, \text{ or} \\ & G/(2\pi f \times C_p), \text{ or} \\ & G \times 2\pi f \times L_p \end{aligned}$$

$$\begin{aligned} \theta \text{ can be calculated as: } & \tan^{-1}(B/G), \text{ or} \\ & \tan^{-1}(2\pi f \times C_p/G), \text{ or} \\ & \tan^{-1}(1/(G \times 2\pi f \times L_p)) \end{aligned}$$

$$G_a = A + (B/|G_m| + C \times |G_m|) \times 100 [\%]$$

$$B_a = A + (B/|B_m| + C \times |B_m|) \times 100 [\%]$$

G_m and B_m are the measured R and B, respectively. A, B, and C are obtained from Figure 9.

D accuracy

Accuracy	$D \leq 0.2$	$0.2 < D$
D_a	$z_a/100$	$(z_a/100) \times (1 + D^2)$

Where Z_a is $|Z|$ accuracy.

L accuracy (depends on D)

Accuracy	$D \leq 0.2$	$0.2 < D$
L_a	$L_a/100$	$L_a(1 + D^2)$

Where,

$$L_a = A + (B/|Z_1| + C \times |Z_1|) \times 100[\%]$$

$|Z_1| = 2\pi f \times L_m$, f is frequency in Hz, and L_m is measured L. A, B, and C are obtained from Figure 9.

C accuracy (depends on D)

Accuracy	$D \leq 0.2$	$0.2 < D$
C_a	C_a	$C_a(1 + D^2)$

Where,

$$C_a = A + (B/|Z_c| + C \times |Z_c|) \times 100[\%]$$

$|Z_c| = 2\pi f \times C_m$, f is frequency in Hz, and C_m is measured C. A, B, and C are obtained from Figure 9.

Common Specifications for Network and Spectrum Measurement

Display

TFT LCD

Size/type	.8.4 inch color LCD
Resolution	.640 x 480
Effective display area	.115 mm x 160 mm (430 x 600 dots)
Number of display channels	.2
Format	.Single, dual split or overwrite, graphic, and tabular
Number of traces	
For measurement	.2 traces
For memory	.2 traces
Data math	. $Gain \times data - offset$, $gain \times memory - offset$, $gain \times (data \text{ memory}) - offset$, $gain \times (data + memory) - offset$, $gain \times (data/memory) - offset$
Data hold	.Maximum hold, minimum hold

Marker

Number of markers

Main marker	.1 for each channel
Submarker	.7 for each channel
Δ marker	.1 for each channel

Storage

Type	.Built-in flexible disk drive, volatile RAM disk memory
Disk format	.LIF, DOS

GPIB

Interface	.IEEE 488.1-1987, IEEE 488.2-1987, IEC 625, and JIS C 1901-1987 standards compatible
Interface function	.SH1, AH1, T6, TE0, L4, LE0, SR1, RL1, PP0, DC 1, DT1, C1, C2, C3, C4, C11, E2
Data transfer formats	.ASCII, 32 and 64 bit IEEE 754 Floating point format, DOS PC format (32 bit IEEE With byte order reversed)

Printer

Interface	.Centronics interface, PCL, and ESC/P
-----------	---------------------------------------

Probe power

Output voltage +15 V (300 mA), -12.6 V (160 mA), GND nominal

Keyboard

Connector Mini Din (IBM PS/2 style)

I/O port (4 bit in 1 S bit out port)

Connector D sub 15 pins

Level TTL Level

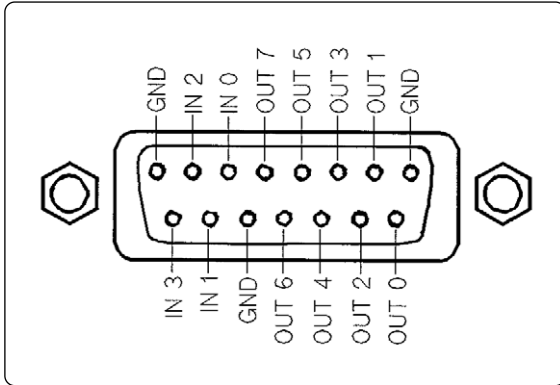

Figure 10. I/O port pin assignments

General Characteristics

Input and output characteristics

External reference input

Frequency 10 MHz ±100 Hz typically

Level > -6 dBm typically

Input impedance 50 Ω nominal

Connector BNC female

Internal reference output

Frequency 10 MHz nominal

Level 2 dBm typically

Output impedance 50 Ω nominal

Connector BNC female

Reference oven output (Option 4396B-1D5)

Frequency 10 MHz nominal

Level 0 dBm typically

Output impedance 50 Ω nominal

Connector BNC female

2nd IF output

Frequency 21.42 MHz nominal
output impedance 50 Ω nominal
Connector BNC female

External trigger input

Level TTL level
Pulse width (T_p) $\geq 2 \mu\text{s}$ typically
Polarity positive/negative selective
Connector BNC female

External program Run/Cont input

Level TTL level
Connector BNC female

Gate output (Option 4396B-1D6)

Level TTL level
Connector BNC female

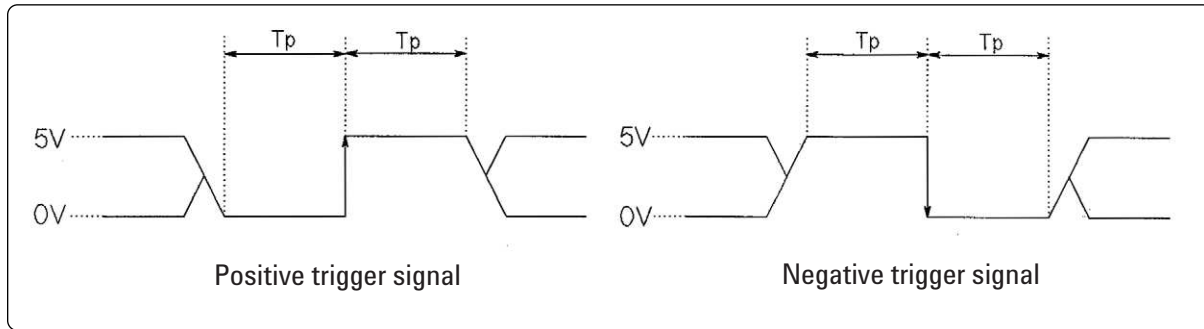

Figure 11. Trigger signal

S-parameter test set interface

Connector D-SUB (25 pin)

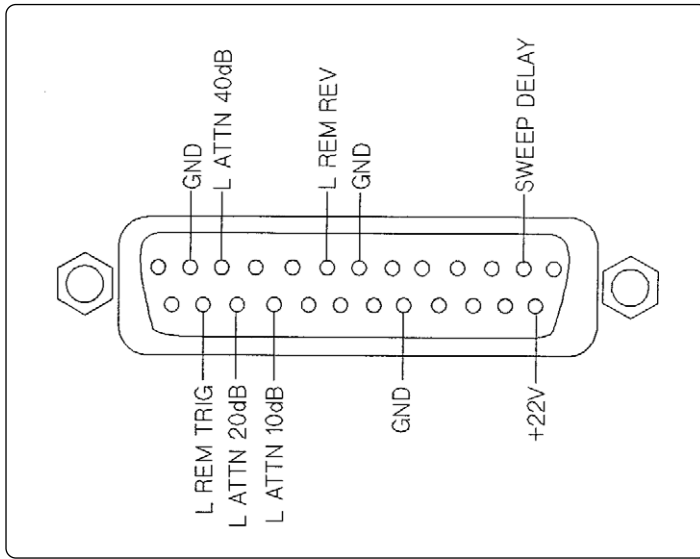

Figure 12. S-parameter test set interface pin assignments

External monitor output

Connector D-Sub 15 pins HD
Resolution 640 x 480 VGA

Operation Conditions

Temperature

Disk drive non-operating condition 0 °C to 40 °C
 Disk drive operating condition 10 °C to 40 °C

Humidity

Wet bulb temperature ≤ 29 °C, without condensation
 Disk drive non-operating condition 15% to 95% RH
 Disk drive operating condition 15% to 80% RH

Altitude 0 to 2,000 meters
Warm-up time 30 minutes

Non-Operation Conditions

Temperature -20 °C to 60 °C
Humidity
 Wet bulb temperature ≤ 45°C, without condensation 15% to 95% RH
Altitude 0 to 4,572 meters

Others

EMC¹ Complies with CISPR 11(1990) / EN 55011 (1991): Group 1, Class A
Complies with IEC 801-2 (1991) / EN 50082-1 (1992): 4 kV CD, 8 kV AD
Complies With IEC 1000-3-2 (1995) / EN 61000-3-2 (1995)
Complies With IEC 1000-3-3 (1994) / EN 61000-3-3 (1995)
Complies With IEC 801-3 (1984) / EN 50082-1 (1992): 3 V/m
Complies With IEC 801-4 (1988) / EN 50082-1 (1992):
1 kV / Main, 0.5 kV / Signal Line

Power requirements . . . 90 V to 132 V, or 198 V to 264 V, 47 to 63 Hz, 300 VA max
Weight 21.5 kg max
Dimensions 425(W) x 235(H) x 553(D) mm

1. When tested at 3 V/m according to IEC 8013/1984, the residual response will be within specifications over the full immunity test frequency range of 26 MHz to 1000 MHz, except when the analyzer frequency is identical to the transmitted interference signal test frequency, the residual response may be up to -95 dBm from 300 MHz to 1000 MHz.

Agilent Technologies' Test and Measurement Support, Services, and Assistance

Agilent Technologies aims to maximize the value you receive, while minimizing your risk and problems. We strive to ensure that you get the test and measurement capabilities you paid for and obtain the support you need. Our extensive support resources and services can help you choose the right Agilent products for your applications and apply them successfully. Every instrument and system we sell has a global warranty. Support is available for at least five years beyond the production life of the product. Two concepts underlie Agilent's overall support policy: "Our Promise" and "Your Advantage."

Our Promise

Our Promise means your Agilent test and measurement equipment will meet its advertised performance and functionality. When you are choosing new equipment, we will help you with product information, including realistic performance specifications and practical recommendations from experienced test engineers. When you use Agilent equipment, we can verify that it works properly, help with product operation, and provide basic measurement assistance for the use of specified capabilities, at no extra cost upon request. Many self-help tools are available.

Your Advantage

Your Advantage means that Agilent offers a wide range of additional expert test and measurement services, which you can purchase according to your unique technical and business needs. Solve problems efficiently and gain a competitive edge by contracting with us for calibration, extra-cost upgrades, out-of-warranty repairs, and onsite education and training, as well as design, system integration, project management, and other professional engineering services. Experienced Agilent engineers and technicians worldwide can help you maximize your productivity, optimize the return on investment of your Agilent instruments and systems, and obtain dependable measurement accuracy for the life of those products.



Agilent Email Updates

www.agilent.com/find/emailupdates

Get the latest information on the products and applications you select.

Agilent T&M Software and Connectivity

Agilent's Test and Measurement software and connectivity products, solutions and developer network allows you to take time out of connecting your instruments to your computer with tools based on PC standards, so you can focus on your tasks, not on your connections. Visit

www.agilent.com/find/connectivity

for more information.

By internet, phone, or fax, get assistance with all your test & measurement needs

Phone or Fax

United States:

(tel) 800 452 4844

Canada:

(tel) 877 894 4414

(fax) 905 282 6495

China:

(tel) 800 810 0189

(fax) 800 820 2816

Europe:

(tel) (31 20) 547 2323

(fax) (31 20) 547 2390

Japan:

(tel) (81) 426 56 7832

(fax) (81) 426 56 7840

Korea:

(tel) (82 2) 2004 5004

(fax) (82 2) 2004 5115

Latin America:

(tel) (305) 269 7500

(fax) (305) 269 7599

Taiwan:

(tel) 0800 047 866

(fax) 0800 286 331

Other Asia Pacific Countries:

(tel) (65) 6375 8100

(fax) (65) 6836 0252

Email: tm_asia@agilent.com

Online Assistance:

www.agilent.com/find/assist

Product specifications and descriptions in this document subject to change without notice.

© Agilent Technologies, Inc. 2003, 2000, 1997

Printed in USA, October 2, 2003

5965-6311E



Agilent Technologies