

Agilent Technologies

OmniBER OTN Jitter Analyzer

J7231B
Technical Data Sheet



Accurate, repeatable jitter measurements
for SONET/SDH/OTN interfaces.



Agilent Technologies

Key Features

- Fully complies and exceeds the requirements of ITU-T O.172 for SONET/SDH Jitter generation & measurement and ITU-T O.173 for OTN Jitter generation & measurement.
- Programmable tolerance/transfer
- Parallel measurements
- Wander test; 52 Mb/s to 10Gb/s, MTIE/TDEV analysis
- Optional spot rate testing
- ITU-T G.709 OTU2 (10.71 Gb/s) testing
- Unframed/framed testing at all rates
- Fully integrated all-rate BER testing:
 - 52 Mb/s to 10.71 Gb/s optical
 - 52/155 Mb/s electrical
- Sequence generation and capture
- SONET/SDH entire overhead capture
- OTN frame capture
- Transmit and receive output triggers for error and alarm events
- All standard error and alarm measurements, plus:
 - optical power, frequency
 - service disruption time, pointer movements
- Simultaneous all-channel testing
- GPIB, LAN and RS-232 remote control
- Universal Instrument Drivers
- Comprehensive on-line help
- 2 year calibration cycle

Product Overview

Introduction

Agilent Technologies' new OmniBER OTN jitter is the world's first tester for all synchronous SDH/SONET rates up to 10Gb/s AND OTU-2 at 10.71Gb/s. The analyzer provides the industry's most accurate jitter test solution. It exceeds the ITU-T O.172 recommendation, giving you extra headroom when testing your devices and designs. By widening component-design margins, the need to retest marginal cases is reduced, meaning lower cost and faster time to market. Whether you're testing SONET, SDH or G.709 OTN network equipment this tester has everything you need to ensure all your designs meet relevant Telcordia and ITU-T jitter recommendations. Your jitter test results will also be available up to 5 times faster with the tester's unique parallel measurement filters.

OmniBER OTN's extensive error performance analysis capabilities will help you to ensure that your new products meet the stringent requirements set out in the latest standards. What's more, Agilent's all-channel monitoring technology lets you simultaneously monitor all STS/AU channels (up to 192) in a received SONET or SDH line signal, continuously, for fast problem resolution and efficient verification of new generation transmission systems.

A comprehensive on-line help system is accessible at the touch of a button, while context sensitive help is provided automatically as you navigate through the user interface. You can also extend the help available by adding your own documentation.

Contents

Instrument Tour	6
Technical Specifications	8
Test interfaces (rates, wavelengths, connectors, line codes)	8
Jitter/Wander generation	9
Jitter measurement	11
Jitter measurement accuracy	14
Jitter measurement results	17
Jitter tolerance	18
Jitter transfer	24
Wander measurement	26
Wander analysis software (E4547A)	26
Wander tolerance	26
Clock Synchronization (inputs, outputs, line frequency offset)	26
Binary Interfaces	27
Signal Structures, Mappings and Payloads	29
Measurements	32
Error and Alarm Generation	34
OTN, SONET and SDH Overhead Testing	35
Payload Drop/Insert capabilities	38
Thru-mode testing	39
Additional features	40
General specifications	40
Regulatory standards	40

Jitter

Jitter capabilities include

- jitter generation
- output jitter measurements
- jitter tolerance
- wander tolerance
- jitter transfer measurements
- standard and user defined jitter masks
- rapid jitter measurements,
- a bank of up to five digital filters each with their own peak detector
- parallel measurement processing

These masks are more flexible than ever, and are ideal for design applications through to production where tailor made masks can be applied. For example, you can select specific frequency ranges and zoom in for closer scrutiny. And for margin testing, you can adjust the masks up or down by up to 100% to make device-testing more stressful.

SmartTest

The front panel Smart Test key provides fast access to the test set's extensive measurement capability. With only a few key presses you can quickly access:

- SignalWizard
- Optical Power measurement
- Frequency measurement
- Trouble scan
- Overhead monitor
- Pointer graph

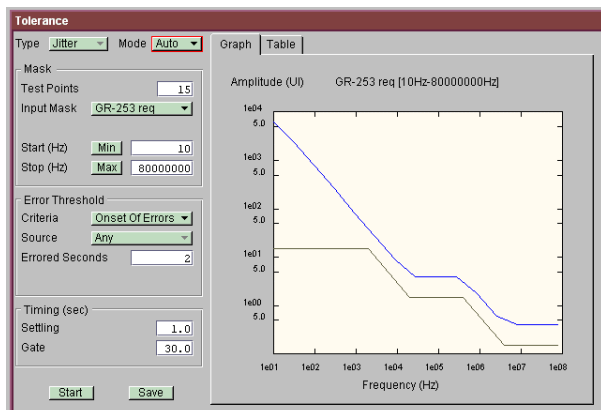

Figure 1. Graphical display of jitter tolerance results

Channel	Size	Trace Message	Signal Label
1,1	STS-48c	San Francisco - NewYork #3	ATM
17,1	STS-12c	San Francisco - Washington #17	HDLC/PPP
21,1	STS-3c	San Francisco - Los Angeles #10	ATM
22,2	STS-1	San Francisco - Phoenix #4	VT
23,1	STS-3c	San Francisco - San Jose #8	ATM
24,1	STS-12c	San Francisco - Chicago #6	HDLC/PPP
28,2	STS-1	San Francisco - Little Rock #1	VT
29,3	STS-1	San Francisco - Minnesota #2	VT
30,1	STS-1	San Francisco - San Jose #2	DS3
32,2	STS-1	San Francisco - Las Vegas #4	VT
34,1	STS-1	San Francisco - Seattle #10	VT
50,3	STS-1	San Francisco - NewYork #20	VT
55,2	STS-1	San Francisco - Denver #5	DS3
63,1	STS-1	San Francisco - Boston #9	DS3
		San Francisco - San Jose # 8	

Figure 2. Clear tabular display of J1 or J2 path trace messages, or those identified based on a sub-string search.

Signal Wizard

Signal Wizard is a unique test tool that has been specifically designed to meet the challenges associated with testing the new generation of SONET/SDH transmission systems - systems that combine grooming, switching and multiplexing in a single unit. With two simple key presses, Signal Wizard automatically:-

- Discovers the line rate and STS/AU channel structure of a valid OC-n/STM-n signal, including any 'mix' of standard and concatenated channels.
- Simultaneously monitors the line signal and all STS/AU channels (up to 192) for errors, alarms and pointer activity.
- Shows which channels are unequipped and the type of service being carried by equipped channels.
- Provides Path Trace message listing and search tools (including sub-string searches) to assist in identifying path routing errors within the network.

OTN testing (ITU-T G.709)

The OTN test capability allows detailed testing of OTU2 (10.71 Gb/s) signals with mapped SONET/SDH payload or test signal mapping.

- Framed/unframed testing at 10.71 Gb/s
- OTN error and alarm generation and detection
- Add correctable and uncorrectable FEC errors
- Measure correctable FEC errors and uncorrectable blocks
- Setup and monitor for all overhead bytes
- Alarm stress testing with 'p', 'n' and 'm' sequences
- Overhead sequence generation and capture
- Frame capture (overhead, payload and FEC blocks)
- Transmit and receive error and alarm event trigger outputs
- Synchronous and asynchronous mapping of SONET/SDH
- Drop-Insert of GCC channels

SONET/SDH testing

The SONET/SDH test capability allows comprehensive testing of synchronous networks with the following interface rates: 10 Gb/s, 2.5 G/s, 622 Mb/s, 155 Mb/s and 52 Mb/s. Supported functionality in Framed/unframed testing at all rates

- SONET/SDH error and alarm generation and detection
- Setup and monitor for all overhead bytes
- Alarm stress testing with 'p', 'n' and 'm' sequences
- Overhead sequence generation and capture
- Entire overhead capture (no payload capture)
- Transmit and receive error and alarm event trigger outputs
- Through mode test capability
- Transparent through mode
- Overhead overwrite - add errors/alarms
- Service disruption test with all payloads
- Setup and monitoring for linear and ring APS/MSP messages
- Active APS test
- Setup and monitoring for J0, J1 and J2 trace messages
- Tandem connection monitoring testing to the SDH standards (both N1 and N2)
- Burst and periodic sequence pointer adjustment control
- Drop-Insert of DCC channels
- External drop-Insert of asynchronous mapped payloads
- Performance analysis G.826, G.828, G.821, M.2101, M.2101.1, M.2110, M.2120

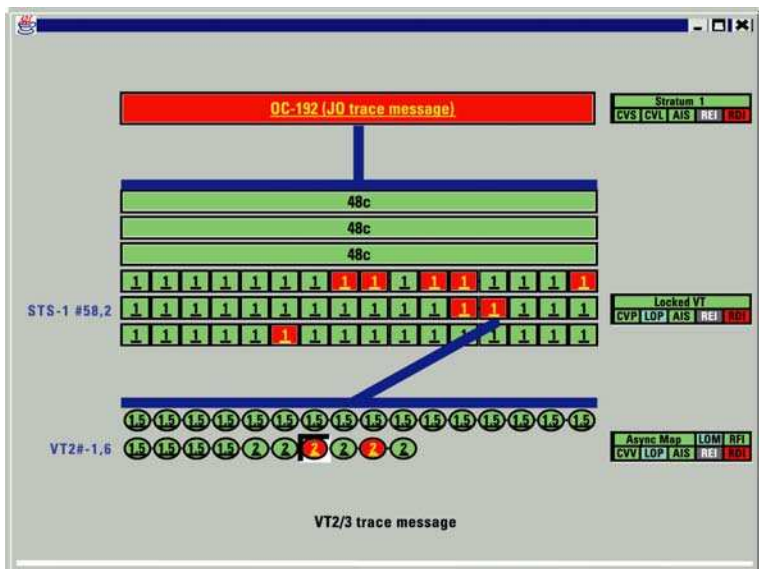

Figure 3. Example SignalWizard display showing real-time status of all channels

Additional measurements

- Optical power
- Line frequency
- Pointer measurements
- Service disruption

Instrument Tour

Figure 4.
Instrument Front Panel

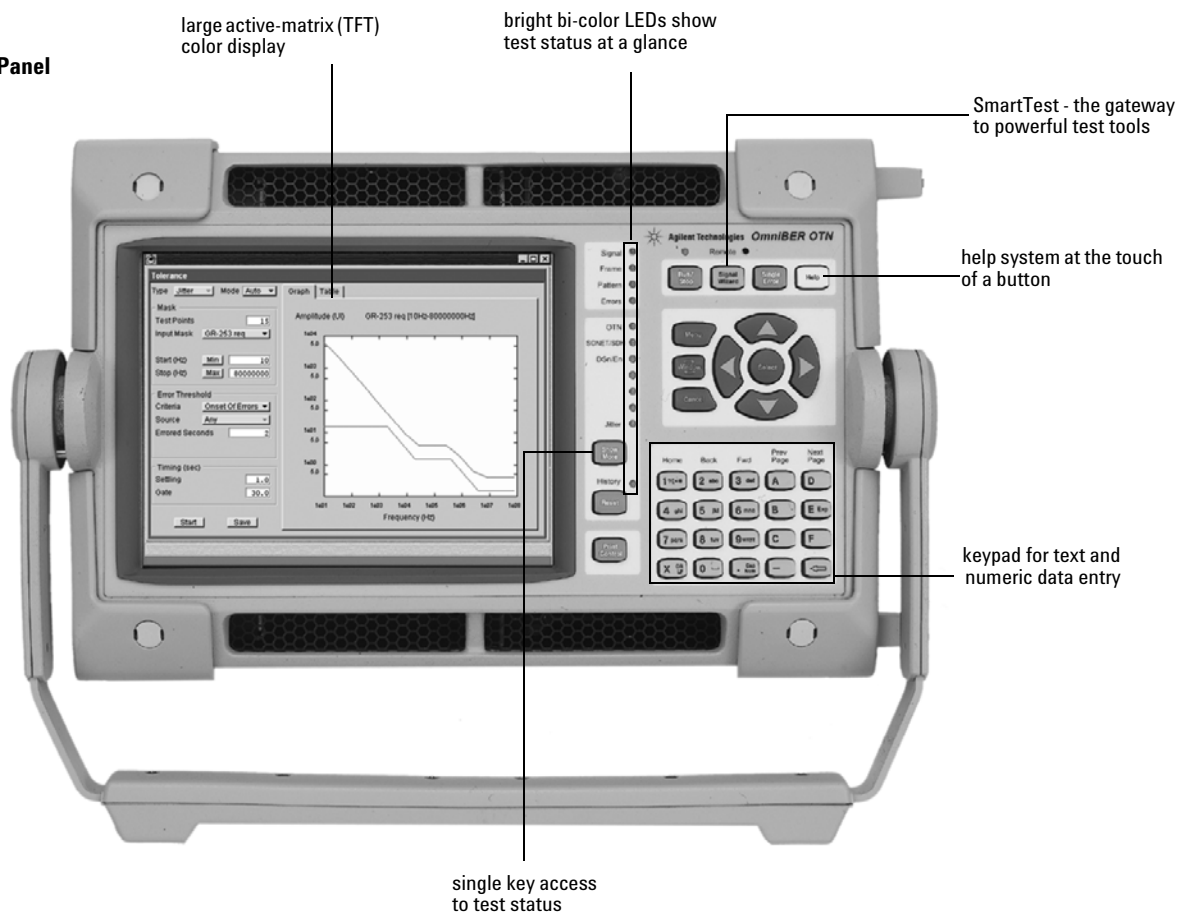
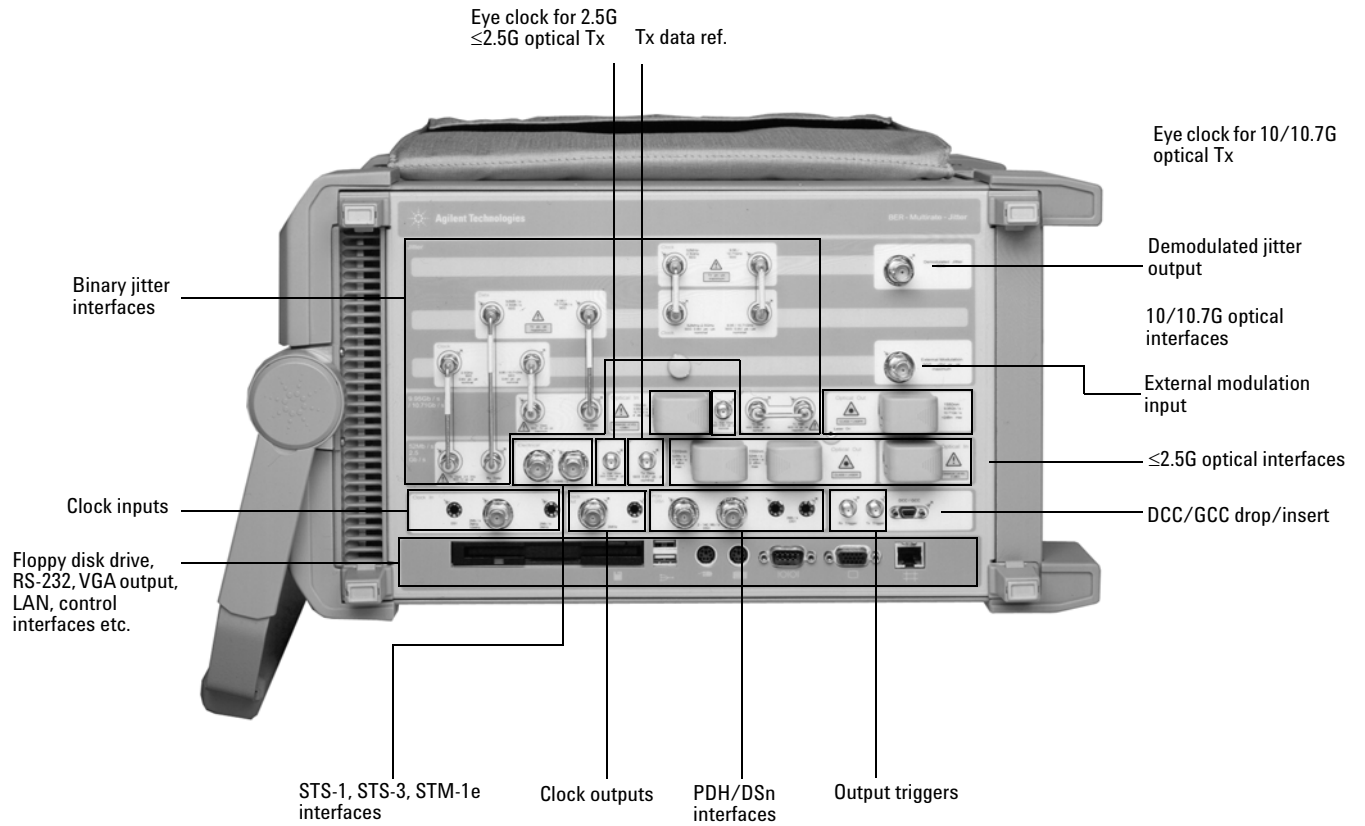

Figure 5.
Instrument Rear Panel



Figure 6.
Instrument Side Panel



Technical Specifications

OmniBER OTN (J7231B)

Test interfaces (rates, wavelengths, connectors, line codes)

Optical	Line Rates Framed: OTU2 OC-1/3/12/48/192 STM-0/1/4/16/64 Unframed: 10.71/9.95/2.48 Gb/s 622/155/52 Mb/s
	Wavelength (≤ 2.5 Gb/s) Option 104 - 1310 nm Option 105 - 1550 nm Option 106 - 1310/1550 nm
	Wavelength (10 Gb/s) Option 108 - 1550 nm Wavelength (10/10.71 Gb/s) Option 112 - 1550 nm
	Connectors Option 609 - FC/ PC Option 610 - SC Option 611 - ST
	Line code NRZ
Jitter Binary Clock & Data Interfaces	Line rates Framed: OC-1/3/12/48/192 STM-0/1/4/16/64 Unframed: 10.71/9.95/2.48 Gb/s 622/155/52 Mb/s
	Connector SMA (50 Ω ac) 0.8V pk-pk nominal

Optical transmitters

	52Mb/s - 2.5Gb/s	10Gb/s & 10.71Gb/s
Line Code	NRZ	NRZ
Wavelength		
1310nm	1280-1335nm	-
1550nm	1500-1580nm	1530-1565nm
Output Power		
1310nm	-2.5 to +2.0dBm	-
1550nm	-2.5 to +2.0dBm	-1.0 to +2.0dBm
Spectral Width (-20dB)	<1.0nm	<1.0nm
Extinction Ratio	>8.2dB	>8.2dB
Pulse Mask	Meets ITU-T G.957 (6/1999) and Telcordia GR-253-CORE issue 3 (9/2000)	
Fiber Type	Single mode	Single mode
Laser Safety	See "Regulatory Standards" section for details	

Optical receivers

	52Mb/s - 2.5Gb/s ⁽¹⁾	10Gb/s & 10.71Gb/s ⁽¹⁾
Line Code	NRZ	NRZ
Wavelength ⁽²⁾	1310/ 1550nm	1310/ 1550nm
Fiber Type	Single mode	Single mode
Damage Input Power	>0dBm	>+2dBm
Operating Range ⁽³⁾	-28dBm to -9dBm	-16dBm to -8dBm

Notes:

- 52-2488 Mb/s: For BER = 1×10^{-10} (input signal extinction ratio ≥ 8.2 dB).
 - 10.71 Gb/s: For BER = 1×10^{-12} (input signal extinction ratio ≥ 8.2 dB).
 - Specifications nominal however the receiver is broadband device and operates over the 1290-1565nm range.
3. Typical specification.

Jitter/Wander generation

Jitter generation rates/interfaces	SDH/SONET: 10Gb/s, 2.5Gb/s, 622Mb/s, 155Mb/s, 52Mb/s OTN: 10.71 Gb/s	
Wander generation rates/interfaces	SDH/SONET: 10Gb/s, 2.5Gb/s, 622Mb/s, 155Mb/s, 52Mb/s	
Modulation source	Internal Modulation: Sinusoidal.	
	External modulation: Frequency Range:	
	<u>Data rate</u>	<u>Modulation frequency</u>
	52M	10Hz-400kHz
	155M	10Hz-1.3MHz
	622M	10Hz-5MHz
	2.5G	10Hz-20MHz
	10G	10Hz-80MHz
	10.71G	10Hz-80MHz
	Signal format: Sinusoidal but can be used with other signal formats. Signal amplitude: 3v pk-pk, typical. Maximum input level: ±5v peak. Connector: BNC, 50Ω nominal unbalanced.	
Jitter/Wander generation capability	The minimum requirements for jitter/wander amplitude/frequency generation function as defined by the standards are; 1. For SDH rates, ITU-T O.172 is used 2. For SONET, GR-253 is used 3. For OTN rates, ITU-T O.173 (draft) is used The OmnibER jitter/wander generation exceeds these requirements	

Frequency resolution	<u>Wander Frequency Range (μHz)</u>		<u>Resolution (μHz)</u>
	10	99.9	0.1
100	999	1	
1,000	9,990	10	
10,000	99,900	100	
100,000	999,000	1,000	
1,000,000	10,000,000	10,000	
Jitter/Wander Amplitude	<u>Jitter Frequency Range (Hz)</u>		<u>Resolution (Hz)</u>
	1	999.9	0.1
	1,000	99,999	1
	100,000	999,990	10
	1,000,000	9,999,900	100
	10,000,000	80,000,000	1,000
	<u>Amplitude Range(UI)</u>		<u>Resolution (UI)</u>
	0.001	99.999	0.001
	100	999.99	0.01
1,000	9,999.9	0.1	
10,000	1,000,000	1	

OmniBER OTN Jitter

Jitter/Wander generation accuracy	Frequency: ±0.1% at all frequencies		
	Amplitude: ±Q% of setting ± 0.02 UIpp		
	<u>Variable error (Q)</u>		
	<u>Data Rate</u> <u>Error,Q (%)</u>	<u>Frequency</u>	<u>Range(Hz)</u>
	52M	± 7% ± 8%	10μ to 300 300 - 400k
	155M	± 7% ± 8% ± 12%	10μ to 500 500 to 500k 500k to 1.3M
	622M	± 7% ± 8% ± 12% ± 15%	10μ to 1k 1k to 500k 500k to 2M 2M to 5M
	2.5G	± 7% ± 8% ± 12% ± 15%	10μ to 5k 5k to 500k 500k to 2M 2M to 20M
	10G	± 7% ± 8% ± 12% ± 15%	10μ to 20k 20k to 500k 500k to 2M 2M to 80M
10.71G	± 8% ± 12% ± 15%	500 to 500k >500k to 1M >1M to 20M	

Intrinsic jitter/wander	<u>Intrinsic jitter/wander</u> (measured in bandwidth f_1 - f_4)		
	Data: (PRBS ²²³⁻¹ bulk filled)	52/155/ 622M	±0.03 UIpp
		2.5/10G	±0.04 UIpp
	Data: (PRBS ²³¹⁻¹ test signal)	10.71G	±0.04 UIpp
Clock: (1010)	All rates	±0.02 UIpp	

Jitter measurement

Jitter measurement rates/interfaces

SDH/SONET: 10 Gb/s, 2.5 Gb/s, 622Mb/s, 155Mb/s, 52 Mb/s.

OTN: 10.71 Gb/s

Optimum input power for jitter measurement

	52Mb/s - 2.5Gb/s	10Gb/s & 10.71Gb/s
Nominal input power	-15 dBm	-9 dBm

Jitter measurement bandwidth

Measurement Range	Demodulation Bandwidth ⁽¹⁾	Filters ^(2,3)		Measurement Bandwidth ^(4,5)
		HP	LP	
52M Line Rate				
'Super-Fine'	10 Hz - 1.6 MHz	100Hz, 12kHz, 20kHz	400kHz	100 Hz - 400 kHz
'Fine'	10 Hz - 1.6 MHz	100Hz, 12kHz, 20kHz	400kHz	100 Hz - 400 kHz
'Medium'	10 Hz - 130 kHz	100Hz, 12kHz, 20kHz	400kHz	100 Hz - 80 kHz
155M Line Rate				
'Super-Fine'	10 Hz - 6.5 MHz	500Hz, 12kHz, 65kHz	1.3MHz	500 Hz - 1300 kHz
'Fine'	10 Hz - 6.5 MHz	500Hz, 12kHz, 65kHz	1.3MHz	500 Hz - 1300 kHz
'Medium'	10 Hz - 400 kHz	500Hz, 12kHz, 65kHz	1.3MHz	500 Hz - 230 kHz
622M Line Rate				
'Super-Fine'	10 Hz - 16.5MHz	1kHz, 12kHz, 250kHz	5MHz	1 kHz - 5000 kHz
'Fine'	10 Hz - 16.5MHz	1kHz, 12kHz, 250kHz	5MHz	1 kHz - 5000 kHz
'Medium'	10 Hz - 1.6 MHz	1kHz, 12kHz, 250kHz	5MHz	1 kHz - 1040 kHz
2.5G Line Rate				
'Super-Fine'	10 Hz - 28 MHz	5kHz, 12kHz, 1MHz	20MHz	5 kHz - 20 MHz
'Fine'	10 Hz - 28 MHz	5kHz, 12kHz, 1MHz	20MHz	5 kHz - 20 MHz
'Medium'	10 Hz - 13 MHz	5kHz, 12kHz, 1MHz	20MHz	5 kHz - 11 MHz

OmniBER OTN Jitter

Measurement Range	Demodulation Bandwidth ⁽¹⁾	Filters ^(2,3)		Measurement Bandwidth ^(4,5)
		HP	LP	
10G Line Rate				
'Super-Fine'	10 Hz - 95 MHz	10kHz, 12kHz, 20kHz, 50kHz, 4MHz	80MHz	20 kHz - 80 MHz
'Fine'	10 Hz - 95 MHz	10kHz, 12kHz, 20kHz, 50kHz, 4MHz	80MHz	20 kHz - 80 MHz
'Medium'	10 Hz - 13 MHz	10kHz, 12kHz, 20kHz, 50kHz, 4MHz	80MHz	20 kHz - 11 MHz
10.7G Line Rate				
'Super-Fine'	10 Hz - 95 MHz	10kHz, 12kHz, 20kHz, 50kHz, 4MHz	80MHz	10 kHz - 80 MHz
'Fine'	10 Hz - 95 MHz	10kHz, 12kHz, 20kHz, 50kHz, 4MHz	80MHz	10 kHz - 80 MHz
'Medium'	10 Hz - 13 MHz	10kHz, 12kHz, 20kHz, 50kHz, 4MHz	80MHz	20 kHz - 11 MHz
Notes: 1. This represents the unfiltered frequency range of the receiver. 2. Independent simultaneous selection of high pass (HP) and low pass (LP) filters [Hz]. 3. Filter transition band responses: HP -20 dB / decade, LP -60 dB / decade. 4. The total jitter receiver accuracy is specified over this -3 dB measurement bandwidth. 5. Measurement bandwidth taken from G.825 Table 1 for 155M to 10G, G.8251 Table 1 for 10.7G				

Measurement filters

Rate	HP1		HP2	HP		LP
	f ₁	f ₂	f ₃	f ₄	f ₅	f ₆
52 M		100 Hz	20 kHz		12 kHz	400 kHz
155 M		500 Hz	65 kHz		12 kHz	1.3 MHz
622 M		1 kHz	250 kHz		12 kHz	5 MHz
2.5 G		5 kHz	1 MHz		12 kHz	20 MHz
10 G /10.71G	10 kHz	20 kHz	4 MHz	12 kHz	50 kHz	80 MHz

Parallel Measurement Filters

This feature provides the ability to measure jitter measurement bandwidth ranges in parallel.

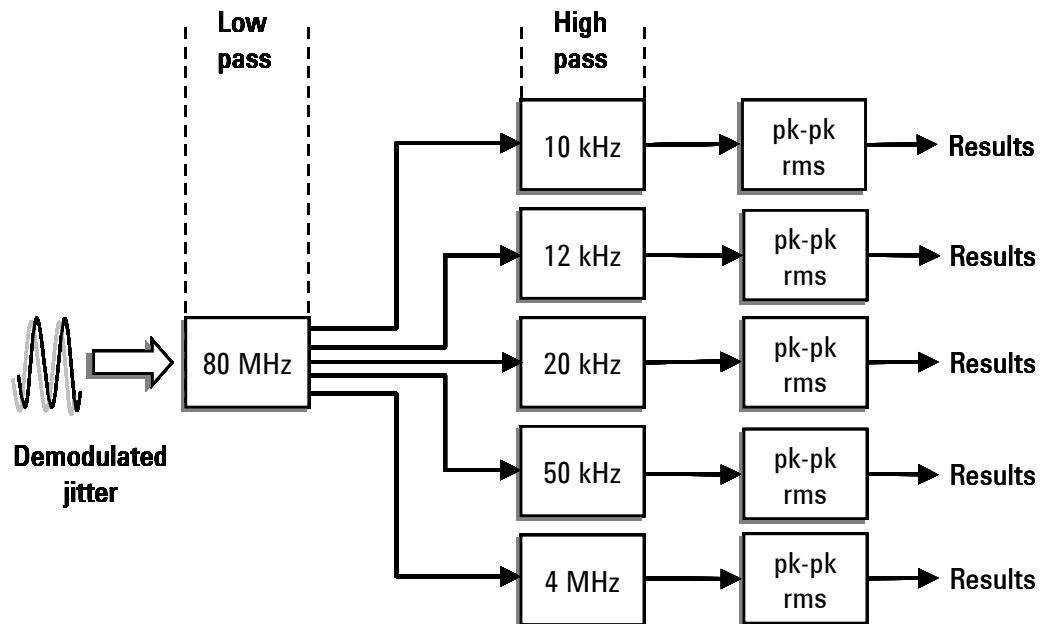

Figure 7.
Parallel Measurement Filters

Results for all measurement bandwidth ranges are calculated simultaneously. This means that up to 5 sets (dependent on line rate) of measurement results are available simultaneously, dependent on the measurement configuration.

Possible measurement configurations are:

- Filters Off
- LP filter on, HP filters off.
- LP filter off, HP filters on (up to 5).
- LP filter on, HP filters on (up to 5).

Jitter measurement accuracy

Receiver accuracy

The measurement accuracy is specified as:

$$UI_{pp} \pm (R\% \text{ of reading} + W + \text{Resolution})$$

$$UI_{rms} \pm \left(\sqrt{(R\% \text{ of reading})^2 + (W)^2} + \text{Resolution} \right)$$

(Spec for UI_{RMS} is typical)

where W represents the intrinsic jitter for a given data pattern and receiver range, R represents the frequency response term of the receiver, and Resolution represents the receiver range resolution.

Intrinsic Term W

Data Rate	Maximum peak-to-peak jitter error (UIpp) for given digital signals								
	Super-Fine, Fine, Medium range								
	(f ₁ -f ₄)			(f ₃ -f ₄)			(HP-f ₄) ⁽⁴⁾		
	0.172/3 (Rx)	Receiver	System	0.172/3 (Rx)	Receiver	System	GR-253	Receiver	System
52M ⁽¹⁾	0.07	0.035	0.07	0.05	0.035	0.07	0.1	0.035	0.07
155M ⁽¹⁾	0.07	0.035	0.07	0.05	0.035	0.07	0.1	0.035	0.07
622M ⁽¹⁾	0.1	0.035	0.07	0.05	0.035	0.07	0.1	0.035	0.07
2.5G ⁽¹⁾	0.1	0.035	0.07	0.05	0.035	0.07	0.1	0.035	0.07
10G ⁽²⁾	0.15	0.05 ⁽⁵⁾	0.08	0.05	0.035 ⁽⁵⁾	0.07	0.1	0.035 ⁽⁵⁾	0.07
10.7G ⁽³⁾	0.15	0.05 ⁽⁵⁾	0.08	0.05	0.035 ⁽⁵⁾	0.07	0.1	0.035 ⁽⁵⁾	0.07

Notes:

1. 52M -2.5G measured with an STM-Nc signal with a 223-1 inverted PRBS, as specified in 0.172
2. 10G measured with an STM-Nc signal with a 231-1 inverted PRBS, as this is the most stringent pattern.
3. 10.7G measured with a OTUk signal (FEC on) with a frame structure and payload mapping of a 231-1 inverted PRBS test signal into a OPUk, as specified in 0.173.
4. Accuracy specified in 3 frequency ranges: f1-f4, f3-f4, HP-f4. Where HP is 12kHz for rates up to 2.5G, and 50kHz at 10 and 10.7G.
5. 10 and 10.7G receiver intrinsic values are nominal.

Data Rate	Maximum rms jitter error (UIrms) for given digital signals								
	Super-Fine, Fine, Medium range								
	(f_1-f_4)			(f_3-f_4)			$(HP-f_4)$ ⁽⁴⁾		
	0.172/3	Receiver	System	0.172/3	Receiver	System	GR-253	Receiver	System
52M ⁽¹⁾	N/A	0.004	0.005	N/A	0.003	0.004	0.01	0.004	0.005
155M ⁽¹⁾	N/A	0.004	0.005	N/A	0.003	0.004	0.01	0.004	0.005
622M ⁽¹⁾	N/A	0.004	0.005	N/A	0.003	0.004	0.01	0.004	0.005
2.5G ⁽¹⁾	N/A	0.004	0.007	N/A	0.003	0.005	0.01	0.004	0.006
10G ⁽²⁾	N/A	0.004 ⁽⁵⁾	0.007	N/A	0.003 ⁽⁵⁾	0.005	0.01	0.004 ⁽⁵⁾	0.006
10.7G ⁽³⁾	N/A	0.004 ⁽⁵⁾	0.008	N/A	0.003 ⁽⁵⁾	0.006	0.01	0.004 ⁽⁵⁾	0.007

Notes:
1. 52M -2.5G measured with an STM-Nc signal with a 223-1 inverted PRBS, as specified in 0.172
2. 10G measured with an STM-Nc signal with a 231-1 inverted PRBS, as this is the most stringent pattern.
3. 10.7G measured with a OTUk signal (FEC on) with a frame structure and payload mapping of a 231-1 inverted PRBS test signal into a OPUk, as specified in 0.173.
4. Accuracy specified in 3 frequency ranges: f_1-f_4 , f_3-f_4 , , $HP-f_4$. Where HP is 12kHz for rates up to 2.5G, and 50kHz at 10 and 10.7G.
5. 10 and 10.7G receiver intrinsic values are nominal.

Accuracy Resolution

Range	Rate	Peak-Peak Resolution (UIpp)	RMS Resolution (UIrms)
'Super-Fine'		±0.001	±0.0005
'Fine'		±0.004	±0.002
'Medium'		±0.040	±0.020
'Extended'	52M	±0.025	±0.012
	155M	±0.075	±0.037
	622M	±0.3	±0.15
	2.5G	±1.2	±0.6
	10G	±5	±2.5
	10.7G	±5	±2.5

Receiver Frequency Inaccuracy Term R

Data Rate	Additional frequency response error		Frequency Range
	R term		
	0.172/3	J7231B	
52M	For Further Study	±5% ±6%	100 Hz to 300 kHz 300 kHz to 400 kHz
155M	±7% ±8% ±10%	±5% ±6% ±7%	500 Hz to 300 kHz 300 kHz to 1 MHz 1 MHz to 1.3 MHz
622M	±7% ±8% ±10% ±15%	±5% ±6% ±7% ±10%	1 kHz to 300 kHz 300 kHz to 1 MHz 1 MHz to 3 MHz 3 MHz to 5 MHz
2.5G	±7% ±8% ±10% ±15% ±20%	±5% ±6% ±7% ±10% ±15%	5 kHz to 300 kHz 300 kHz to 1 MHz 1 MHz to 3 MHz 3 MHz to 10 MHz 10 MHz to 20 MHz
10G	±7% ±8% ±10% ±15% ±20%	±5% ±6% ±7% ±10% ±15%	20 kHz to 300 kHz 300 kHz to 1 MHz 1 MHz to 3 MHz 3 MHz to 10 MHz 10 MHz to 80 MHz
10.7G	±7% ±8% ±10% ±15% ±20%	±5% ±6% ±7% ±10% ±15%	20 kHz to 300 kHz 300 kHz to 1 MHz 1 MHz to 3 MHz 3 MHz to 10 MHz 10 MHz to 80 MHz
<p>Note: The OmniBER OTN J7231B exceeds the requirements in ITU-T O.172. The 'R term' values shown are with respect to a calibrated value at 100kHz. At 100kHz, R=0. The frequency response term will only apply over the instrument measurement bandwidth.</p>			

Jitter measurement results

Jitter Hits

Jitter hits detected when the programmable thresholds for positive or negative jitter values are exceeded.

Hit threshold	+ve peak -ve peak (+ve and -ve peaks are independently settable) Both are specified in UI, as below:				
	Range	Rate	Minimum value (UI)	Maximum value(UI)	Resolution(UI)
	'Super-Fine'		0.025	0.4	0.005
	'Fine'		0.025	1.5	0.005
	'Medium'		0.25	15	0.05
	'Extended'	52M	0.5	32	0.1
		155M	0.5	32	0.1
		622M	0.5	128	0.1
		2.5G	5.0	1,250	1.0
		10G	5.0	5,000	1.0
		10.7G	5.0	5,000	1.0
Total results	+ve hit count -ve hit count hit seconds hit free seconds				

Amplitude																						
Total & last second results	<p>A display of the 'total' and 'last second' jitter amplitude results for each of the active receiver measurement bandwidths (each filter bandwidth is selected individually).</p> <p>+ve peak -ve peak peak-to-peak RMS</p>																					
Parallel filters	<p>A display of the 'peak-to-peak' & RMS jitter amplitude results for ALL of the active receiver measurement bandwidths.</p>																					
Demodulated jitter out																						
	<table border="1"> <thead> <tr> <th>Range</th> <th colspan="2">Gain (UIpp/V) ⁽¹⁾</th> </tr> </thead> <tbody> <tr> <td>Super-Fine</td> <td></td> <td>1 mUI/mV</td> </tr> <tr> <td>Fine</td> <td></td> <td>5 mUI/mV</td> </tr> <tr> <td>Medium</td> <td></td> <td>50 mUI/mV</td> </tr> <tr> <td rowspan="4">Extended</td> <td>52M / 155M</td> <td>50 mUI/mV</td> </tr> <tr> <td>622M</td> <td>0.1 UI/mV</td> </tr> <tr> <td>2.5G</td> <td>1 UI/mV</td> </tr> <tr> <td>10/10.7G</td> <td>10 UI/mV</td> </tr> </tbody> </table> <p>Notes: 1. Nominal</p> <p>Format: Reconstructed analogue output, 50Ω single ended DC coupled to ground. The filter bandwidth of the demodulated output can be selected when more than one filter is active.</p>	Range	Gain (UIpp/V) ⁽¹⁾		Super-Fine		1 mUI/mV	Fine		5 mUI/mV	Medium		50 mUI/mV	Extended	52M / 155M	50 mUI/mV	622M	0.1 UI/mV	2.5G	1 UI/mV	10/10.7G	10 UI/mV
Range	Gain (UIpp/V) ⁽¹⁾																					
Super-Fine		1 mUI/mV																				
Fine		5 mUI/mV																				
Medium		50 mUI/mV																				
Extended	52M / 155M	50 mUI/mV																				
	622M	0.1 UI/mV																				
	2.5G	1 UI/mV																				
	10/10.7G	10 UI/mV																				

Jitter tolerance	
Jitter tolerance modes	
Auto tolerance, Fast auto tolerance, Sweep, Spot	
Auto tolerance	<p>Automatic jitter generation/measurement mode. Determines the maximum jitter amplitude tolerated by the DUT, and compares it against the selected tolerance mask. The result of this measurement shows the margin to which the device passes or fails against the selected tolerance mask.</p>
Fast auto tolerance	<p>Automatic jitter generation/measurement mode. Tests DUT for conformance to the tolerance mask. The frequency/amplitude values are set precisely to the values defined by the tolerance mask. At each frequency point, the receiver is checked against the desired performance criteria. The result of this measurement is shown as a PASS or FAIL.</p>
Sweep	<p>Automatic jitter generation mode. Equivalent to fast auto tolerance without measurement i.e. generation only.</p>
Spot	<p>Manual jitter generation mode. Jitter is generated at selected spot frequencies at amplitude defined by the selected tolerance mask.</p>
Jitter tolerance test methods	
Both 'Onset of errors' and 'BER penalty' methods are supported:	
Onset of errors	<p>The jitter amplitude is increased until the number of errors crosses a certain threshold. All (non-FEBE) error sources will be tested against a threshold of 0 at each amplitude point as per 'Supplement No. 3.8 of the O-Series Recommendations'.</p>
BER penalty	<p>Only bit errors are tested against a selected error threshold at each amplitude point as per 'Supplement No. 3.8 of the O-Series Recommendations'.</p> <p>In either case, any active alarm will result in the test recording a failure.</p>
Test configuration	
Number of points	1 to 100
Input Mask	Select from Fixed masks or User programmable masks.
Frequency range	<p>The selected tolerance mask defines the default frequency range for the measurement. To enable the user to 'zoom-in' to a particular frequency range of interest, the frequency range for the measurement can be changed.</p> <ul style="list-style-type: none"> 10Hz to 80MHz (dependent on rate)
Settling time	Time taken for DUT to settle, before measurement, 0.1 to 99.9s in 0.1s steps
Gate time	Time spent measuring, 0.1 to 99.9s in 0.1s steps.

Error criteria	Onset of errors: Errored seconds = 2. All errors. Gate time = 30s. BER penalty: 100 or more BIT errors, observed during 1s. User defined criteria can also be applied to the above.		
Error Criteria ⁽¹⁾	BER Penalty	Onset of Errors	Error Count
	Point where 100 or more Bit errors occur in 1s.	Point where 2 errored seconds occur in 30s.	Point where errors (equal to or more than the set Count) occur during the set Gate Time.
Error Source	Bit	All	Select from: OTN: OTU BIP,ODU BIP, Bit, All ⁽²⁾ SONET: B1,B2,B3,Bit, All ⁽²⁾ SDH: B1,B2,B3,IEC,OEI,Bit, All ⁽²⁾
Error Count	100	Not Valid	n where 1≤n≤1,000,000
Error Rate	Calculated ^(3,4)	Not Valid	Calculated ⁽³⁾ (no Error Rate field when Error Source is 'All')
Errored Seconds	Not Valid	2	Not Valid
Gate Time	0.1 to 99.9 sec, 0.1sec steps. Default - 1s	0.1 to 99.9 sec, 0.1 sec steps. Default - 30s	0.1 to 99.9 sec, 0.1 sec steps.
Settling Time	0.1 to 99.9 sec, 0.1 sec steps.	0.1 to 99.9 sec, 0.1 sec steps.	0.1 to 99.9 sec, 0.1 sec steps.
Notes: 1. Criteria selection affects the availability of Error Source/Count/Rate and Errored seconds fields. 2. The selection, Error Source = 'All', sets a criteria of 'any errors'. 3. Error Rate calculated is affected by the Gate Time configured. 4. When the Rx input to OmniBER is OTN, BER is measured by leaving the FEC enabled and counting the number of corrected bit errors per unit time.			

Jitter tolerance results

The frequency/amplitude result pairs results can be displayed in tabular or graphical form.

Graph

The graphical display shows the measurement results plotted against the selected tolerance mask.

A failure is indicated if the measured point is below the mask.

Text

The tabular results show the following information displayed for each point:

- Point Number
- Frequency
- Mask Value
- Result
- Pass / Fail Margin
- Pass / Fail Indication

Jitter Tolerance Masks

The following fixed Jitter Tolerance masks are provided:

Data Rate	OTNMasks ⁽¹⁾	SDH Masks ⁽¹⁾		SONETMasks ⁽¹⁾
	G.8251	G.825	G.783	GR-253
52 Mb/s				•
155 Mb/s		•	•	•
622 Mb/s		•	•	•
2.5 Gb/s		•	•	•
10 Gb/s		•	•	•
10.7 Gb/s	•			

Notes:
 1. The list of masks available for selection is dependent on the input data rate of the network element under test only, i.e. it is not restricted by the selected instrument mode (OTN, SDH, or SONET).

G.8251 Masks

Rate	Mask	G.825 Mask
10.7 ¹ Gb/s	G.8251	Table 3, Figure 2

G.825 Masks

Both variants of the G.825 mask are supported:

1. G.825 1.5M: networks based on the 1.5 Mb/s hierarchy
2. G.825 2M: networks based on the 2 Mb/s hierarchy

Rate	Mask	G.825 Mask
155 Mb/s	G.825 (1.5Mb/s networks)	Table 3, Figure 1
	G.825, (2Mb/s networks)	
622 Mb/s	G.825 (1.5Mb/s networks)	Table 5, Figure 3
	G.825, (2Mb/s networks)	
2.5 Gb/s	G.825 (1.5Mb/s networks)	Table 6, Figure 4
	G.825, (2Mb/s networks)	
10 Gb/s	G.825 (1.5Mb/s networks)	Table 7, Figure 5
	G.825, (2Mb/s networks)	

G.783 Masks

Both variants of the G.783 mask are supported:

1. G.783 Type A: Type A regenerators require to tolerate input jitter as per G.825. The high-band portion of the G.825 jitter tolerance masks is given in G.783.
2. G.783 Type B: Type B regenerators have reduced jitter tolerance.

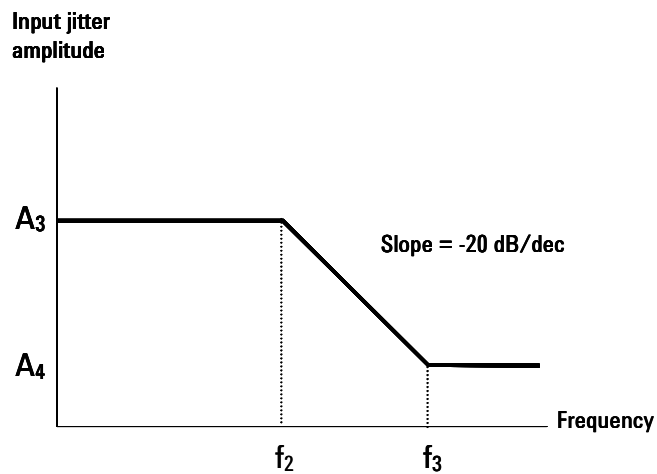

Figure 8.
G. 783 Input Jitter Tolerance Mask

Rate	G.783 Mask	f_1	f_2	f_3	f_4	A_3	A_4
155 Mb/s	Type A (Table 15-1)	500	6.5k	65k	1.3M	1.5	0.15
622 Mb/s	Type A (Table 15-1)	1k	25k	250k	5M	1.5	0.15
2.5 Gb/s	Type A (Table 15-1)	5k	100k	1M	20M	1.5	0.15
10 Gb/s	Type A (Table 15-1)	10k	400k	4M	80M	1.5	0.15

Rate	G.783 Mask	f_1	f_2	f_3	f_4	A_3	A_4
155 Mb/s	Type B (Table 15-1a)	10	1.2k	12k	1.3M	1.5	0.15
622 Mb/s	Type B (Table 15-1a)	10	1.2k	12k	5M	1.5	0.15
2.5 Gb/s	Type B (Table 15-1a)	10	1.2k	12k	20M	1.5	0.15
10 Gb/s ³	Type B (Table 15-1a)	10	1.2k	12k	80M	1.5	0.15

GR-253 Masks

Two variants of the GR-253 mask are supported:

1. GR-253 Requirement Mask
2. GR-253 Objective Mask

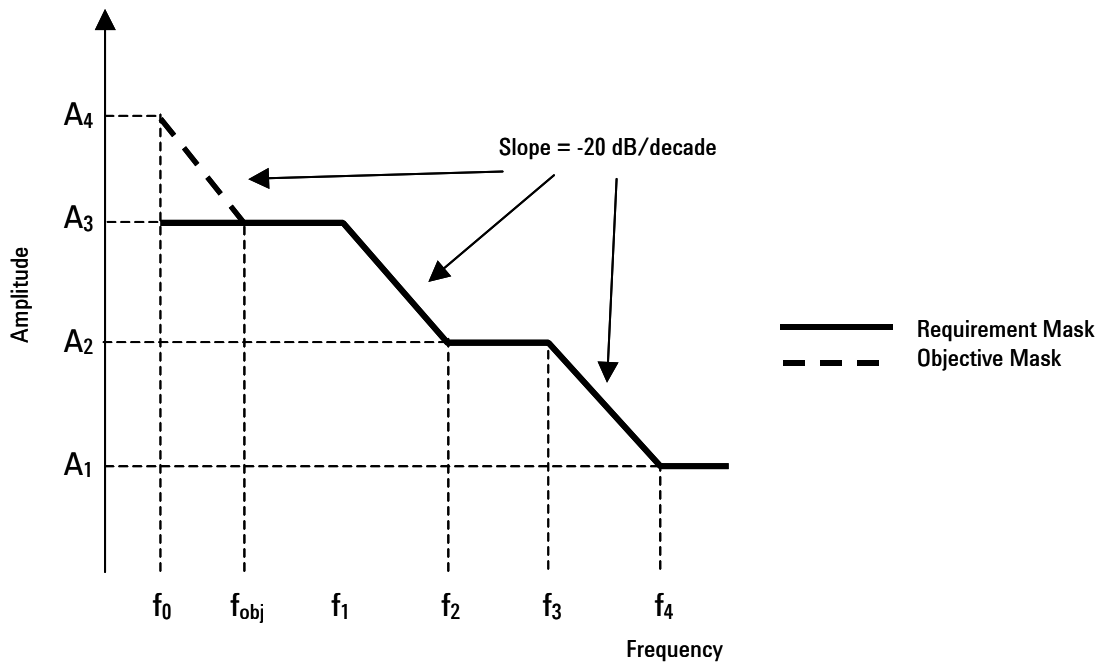

Figure 9.
GR-253 Input Jitter Tolerance Masks

Rate	Mask	F0	Fobj	F1	F2	F3	F4	F5	A1	A2	A3	A4
		(Hz)	(Hz)	(Hz)	(Hz)	(kHz)	(kHz)	(kHz)	(UI)			
52 Mb/s	GR-253 ¹	10	-	30	300	2	20	400	0.15	1.5	15	-
155 Mb/s	GR-253 ¹	10	-	30	300	6.5	65	1300	0.15	1.5	15	-
622 Mb/s	GR-253 ¹	10	18.5	30	300	25	250	5000	0.15	1.5	15	27.8
2.5 Gb/s	GR-253 ¹	10	70.9	600	6000	100	1000	20000	0.15	1.5	15	106.4
10 Gb/s	GR-253 ¹	10	296	2000	20000	400	4000	80000	0.15	1.5	15	444.6

Note - Values taken from GR-253, Figure 5-28.

User-programmable masks

Ability to create, edit and title user defined masks.

No of masks	Up to 10 user masks
Mask title	15 character string
Mask create/delete	A flexible mask creation scheme is provided, offering the following features: New: Create user mask. Copy: From 'preset' or 'user'. Allows a mask to be copied from one of the preset masks defined by the standards, or another mask. Delete: Delete user mask.
Mask edit	Scale factor: Allows all points on the mask to be shifted by 0 to +/- 100%, with single percent resolution. Useful for margin testing. Delete: single point Add/Edit: single point.
Display	The user mask is displayed in both tabular and graphical form.

Jitter transfer

Jitter transfer function

An automatic jitter transfer function is available when both transmitter and receiver are configured to the same rate.

Test configuration

Number of points	1 to 100
Input mask	Fixed masks: as per Jitter Tolerance User Programmable masks: up to 10
Frequency range	10Hz to 80MHz (dependent on rate)
Offset	An offset in the range -2.00 dB to +2.00 dB in steps of 0.01 dB can be added to the selected Pass Mask.
Settling time	5 to 30s, in 1s steps
Gate time	5 to 30s, in 1s steps

Jitter transfer receiver

A narrowband filtering technique is used when performing a jitter transfer measurement.

Dynamic range	+5 dB to -40 dB.
Recommended settling time	10s
Recommended gating time:	20s

Jitter transfer accuracy

The specification of SDH equipment jitter transfer characteristics in G.783 [5] uses a gain-versus-frequency mask to limit the maximum transfer gain (P) and the maximum transfer bandwidth (f_C). This mask is specified in between the frequency range f_L to f_H . The accuracy of the jitter transfer measurement depends on several factors: the repeatability of the jitter generator's performance, the linearity and repeatability of the jitter measurement equipment's performance, and the noise floor of the measurement. Where the jitter frequency f_m is less than f_C , the measurement accuracy affects the determination of whether the gain limit P has been met. Where the jitter frequency f_m is greater than f_C , the measurement accuracy affects the determination of whether the bandwidth limitation mask above f_C is not exceeded.

The total measurement error in the jitter frequency range $f_L = 0.01 \cdot f_C$ and $f_H = 100 \cdot f_C$ or f_4 , if f_4 is lower than $100 \cdot f_C$ and for input jitter amplitudes $\geq 0.15 U_{pp}$ shall be less than:

$$\pm 0.05 \text{ dB} \pm 0.12 \cdot g$$

where g is the measured jitter transfer gain at the jitter frequency f_m in dB.

Jitter transfer results

The jitter transfer results can be displayed in tabular or graphical form.

Graph	The result is plotted on a graph of gain versus frequency. The pass mask is displayed on the graph as well as the results.
Text	Point number, frequency, mask value, result, pass/fail indication.

Jitter Transfer pass masks

Data Rate	OTN Masks (1)	SDH Masks (1)				SONET Masks (1)	
		G.825		G.783	G.783	GR-253	
Input Mask	G.8251 ODCr	1.5M	2M	A	B	Req	Obj
		Pass Mask		G.783		G.783	GR-253
	A		B				
52 Mb/s						•	
155 Mb/s				•			•
622 Mb/s				•			•
2.5 Gb/s				•			•
10 Gb/s				•			•
10.7 Gb/s	•						

Notes:
1. The list of masks available for selection is dependent on the data rate only (Tx - Input Mask, Rx - Pass Mask) only, i.e. it is not dependent on the selected instrument mode (OTN, SDH, or SONET).

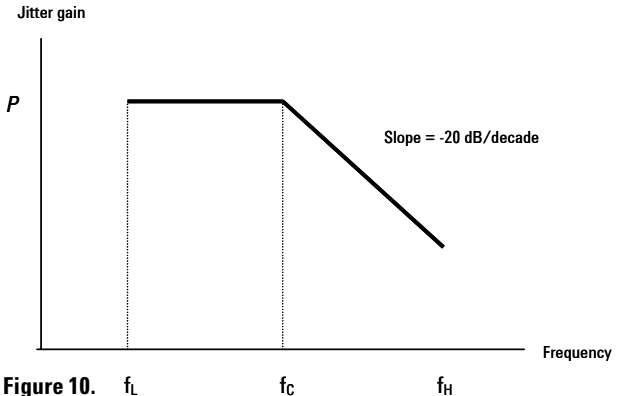

Figure 10. Jitter Transfer Pass Mask

f_L and f_H define the start and stop frequency respectively for the jitter transfer measurement.

G.8251 Masks

Rate	Mask	f_L (Hz)	f_C (Hz)	f_H (Hz)	P (dB)	Input Mask
10.7 Gb/s	G.8251, ODCr	10k	1000k	80M	0.1	G.8251

G.783 Jitter Transfer Pass Mask

Two variants of the G.783 pass mask are supported:

- G.783 Type A
- G.783 Type B

Rate	Mask	f_L (Hz)	f_C (Hz)	f_H (Hz)	P (dB)
155Mb/s	G.783, Type A	1.3k	130k	1.3M	0.1
622Mb/s	G.783, Type A	5k	500k	5M	0.1
2.5 Gb/s	G.783, Type A	20k	2000k	20M	0.1
10 Gb/s	G.783, Type A	10k	1000k	80M	0.1

Rate	Mask	f_L (Hz)	f_C (Hz)	f_H (Hz)	P (dB)
155Mb/s	G.783, Type B	0.3k	30k	1.3M	0.1
622Mb/s	G.783, Type B	0.3k	30k	3M	0.1
2.5 Gb/s	G.783, Type B	0.3k	30k	3M	0.1
10 Gb/s	G.783, Type B	0.3k	30k	3M	0.1

GR-253 Jitter Transfer Pass Mask

Rate	Mask	f_L (Hz)	f_C (Hz)	f_H (Hz)	P (dB)
52Mb/s	GR-253-CORE	0.4k	40k	400k	0.1
155Mb/s	GR-253-CORE	1.3k	130k	1.3M	0.1
622Mb/s	GR-253-CORE	5k	500k	5M	0.1
2.5 Gb/s	GR-253-CORE	20k	2000k	20M	0.1
10 Gb/s	GR-253-CORE	1.2k	120k	12M	0.1

Calibration

Before a test cycle can be performed, the instrument must be connected back-to-back in order to perform a calibration cycle. This will need to be redone after a configuration change is performed or when any of the parameters associated with the test are changed.

Note: To meet the quoted accuracy, the instrument MUST have been switched on in stable climatic conditions for at least 1 hour before starting a calibration cycle. Also, from start of calibration until end of measurement, the climatic conditions MUST remain stable.

Wander measurement									
Wander measurement rates	SDH/SONET: 10Gb/s, 2.5 Gb/s, 622 Mb/s, 155 Mb/s, 52 Mb/s.								
Wander timing reference	Wander measurement can only be performed on a locked synchronous system where one clock reference is used.								
Wander measurement bandwidth	All rates: 10μHz to 10Hz.								
Wander measurement range	The dynamic range of the TIE measurement is a minimum of $\pm 1 \times 10^9$ ns.								
Wander sampling rate	Sampling rate is 50/s.								
Wander measurement accuracy	For each measurement of TIE, over an observation interval of length t (i.e. current test time), the total TIE measurement error shall be less than: <table border="1" data-bbox="479 846 795 1165"> <thead> <tr> <th colspan="2">Measurement accuracy</th> </tr> </thead> <tbody> <tr> <td>0.172</td> <td>$\pm 5\%$ of the measured TIE value $\pm Z_0(\tau)$</td> </tr> <tr> <td></td> <td>$Z_0(\text{ns}) = 2.5 + 0.0275\tau, 0.05 \leq \tau \leq 1000$ $Z_0(\text{ns}) = 29 + 0.001\tau, \tau > 1000$</td> </tr> <tr> <td>J7231B</td> <td>$\pm 3\%$ of the measured TIE value $\pm 2.5\text{ns}$</td> </tr> </tbody> </table>	Measurement accuracy		0.172	$\pm 5\%$ of the measured TIE value $\pm Z_0(\tau)$		$Z_0(\text{ns}) = 2.5 + 0.0275\tau, 0.05 \leq \tau \leq 1000$ $Z_0(\text{ns}) = 29 + 0.001\tau, \tau > 1000$	J7231B	$\pm 3\%$ of the measured TIE value $\pm 2.5\text{ns}$
Measurement accuracy									
0.172	$\pm 5\%$ of the measured TIE value $\pm Z_0(\tau)$								
	$Z_0(\text{ns}) = 2.5 + 0.0275\tau, 0.05 \leq \tau \leq 1000$ $Z_0(\text{ns}) = 29 + 0.001\tau, \tau > 1000$								
J7231B	$\pm 3\%$ of the measured TIE value $\pm 2.5\text{ns}$								
Frequency accuracy	10Hz \pm 5%								
Wander measurement results	Text <ul style="list-style-type: none"> • Time Interval Error (ns or UI) • +ve Peak (ns or UI) • -ve Peak (ns or UI) • Peak-Peak (ns or UI) • Frequency offset (ppm) • Frequency drift (ppm/sec) 								

Wander analysis software (E4547A)	
The Wander analyzer software provides the <i>real-time</i> calculation of the MTIE, TDEV and MRTIE wander performance indices. The software is Windows compatible.	
Measurement rates	SONET: OC-192, OC-48, OC-12, OC-3, OC-1 SDH: STM-64, STM-16, STM-4, STM-1, STM-0
Wander analysis results	TIE, MTIE, MRTIE, TDEV, frequency offset and frequency drift

Standards compliance	Complies with all relevant ITU-T, Telcordia, ETSI, ANSI standards. ITU-T: G.783, G.811, G.812, G.813, G.823, G.824. Telcordia: GR-253-CORE, GR-1244-CORE. ANSI: T1.101. ETSI: ETS 300 462, ETS TM 3067.
User defined pass mask	In addition to providing all relevant masks from the standards bodies, the software provides the ability to quickly and easily generate additional user defined pass masks.
Software controls	Software provides user control of Cursor, Markers, Zoom In/Out, TIE Value and Transient search.
Minimum PC requirements	Processor: 166 MHz Pentium MMX (Windows 2000, NT 4.0, 98, 95) 300 MHz Pentium MMX (Windows XP) Memory: 64M (Windows 2000, NT 4.0, 98, 95) 128M (Windows XP) Comm Port: RS-232 connection to OmniBER

Wander tolerance	
Wander tolerance mode	Spot: Manual wander generation mode. Wander is generated at selected spot frequencies at amplitudes defined by the selected tolerance mask.
Wander tolerance masks	<ul style="list-style-type: none"> • G.812 (sinusoidal) • G.813 (sinusoidal) • G.825

Clock Synchronization (inputs, outputs, line frequency offset)	
Clock references	Internal: ± 4.5 ppm Includes setting accuracy, stability over temperature and aging. External Clock Inputs: BITS (1.5 Mb/s): Bantam (100Ω balanced). MTS (2 MHz and 2 Mb/s): BNC (75Ω unbalanced) and Bantam (120Ω balanced) Loop-timed: Transmitter timed by a clock recovered from the receiver.
Frequency offset	Offsets the transmitted line signal relative to the selected clock reference. Offset: ± 100 ppm in 0.1 ppm step. Offset accuracy: 0.02 ppm Note: For 10Gb/s and 10.71Gb/s operation the total of external clock reference offset and transmitter line rate offset must not exceed ± 90 ppm. For all other rates the combined offsets must not exceed ± 120 ppm.

Clock outputs	Output clocks generated relative to the selected transmit reference clock. BITS (1.5Mb/s): Bantam (100Ω balanced). MTS (2 MHz): BNC (75Ω unbalanced).
Eye clock outputs	Clock outputs that are frequency locked to the transmitted optical line signal. Rate: 52/155/622 Mb/s and 2.5 Gb/s: Output line rate divided by four. 10 Gb/s: Output line rate divided by sixteen (622 MHz nominal). 10.71 Gb/s: Output line rate divided by sixteen (669 MHz nominal) Level: Nominal ECL, ac coupled. Impedance: Drives nominal 50Ω inputs. Connector: SMA.

Binary Interfaces

Binary Interface Transmitter		
Clock		
Clock Waveform	Square wave	
Clock Duty Cycle	40:60 worst case	
Level	Min: 600 mV, Max: 1.0 V	
Overshoot	10 %	
Output Impedance	50Ω ac	
Return Loss	>10 dB at clock frequency	
Rise time, fall time	10 / 10.7G	<30 ps
	2.5G	<120 ps
	622M	<480 ps
	155M	<1920 ps
	52M	<2000 ps
Maximum Power	15 dBm	
Reverse damage voltage	±5 V dc	
Connector	SMA	

Note - All specifications are nominal.

Data		
Data Format	NRZ	
Level	Min: 600 mV, Max: 1.0 V	
Overshoot	10 %	
Output Impedance	50Ω ac	
Return Loss	>10 dB at ½ bit rate	
Rise time, fall time	10 / 10.7G	<30 ps
	2.5G	<120 ps
	622M	<480 ps
	155M	<1920 ps
	52M	<2000 ps
Maximum Input Power	15 dBm	
Reverse damage voltage	±5 V dc	
Connector	SMA	

Note - All specifications are nominal.

OmniBER OTN Jitter

Binary Interface Receiver																			
Clock																			
Clock Waveform	Square wave																		
Clock Duty Cycle	40:60 worst case																		
Level sensitivity	200 mV p-p																		
Level (maximum)	1.2 V																		
Termination	50Ω ac																		
Return Loss	>15 dB at clock frequency																		
Rise time, fall time																			
	<table border="1"> <thead> <tr> <th></th> <th>10 / 10.7G</th> <th>2.5G</th> <th>622M</th> <th>155M</th> <th>52M</th> </tr> </thead> <tbody> <tr> <td>(200 mV)</td> <td><30 ps</td> <td><120 ps</td> <td><480 ps</td> <td><1920 ps</td> <td><2000 ps</td> </tr> <tr> <td>(400 mV)</td> <td><45 ps</td> <td><180 ps</td> <td><720 ps</td> <td><2880 ps</td> <td><2880 ps</td> </tr> </tbody> </table>		10 / 10.7G	2.5G	622M	155M	52M	(200 mV)	<30 ps	<120 ps	<480 ps	<1920 ps	<2000 ps	(400 mV)	<45 ps	<180 ps	<720 ps	<2880 ps	<2880 ps
	10 / 10.7G	2.5G	622M	155M	52M														
(200 mV)	<30 ps	<120 ps	<480 ps	<1920 ps	<2000 ps														
(400 mV)	<45 ps	<180 ps	<720 ps	<2880 ps	<2880 ps														
Maximum Input Power	15 dBm																		
Damage voltage	±5 V dc																		
Connector	SMA																		

Note - All specifications are nominal.

Data																			
Data Format	NRZ																		
Level	Min: 200 mV, Max: 1.2 V																		
Return Loss	>15 dB at ½ bit rate																		
Rise time, fall time																			
	<table border="1"> <thead> <tr> <th></th> <th>10 / 10.7G</th> <th>2.5G</th> <th>622M</th> <th>155M</th> <th>52M</th> </tr> </thead> <tbody> <tr> <td>(200 mV)</td> <td><30 ps</td> <td><120 ps</td> <td><480 ps</td> <td><1920 ps</td> <td><2000 ps</td> </tr> <tr> <td>(400 mV)</td> <td><45 ps</td> <td><180 ps</td> <td><720 ps</td> <td><2880 ps</td> <td><2880 ps</td> </tr> </tbody> </table>		10 / 10.7G	2.5G	622M	155M	52M	(200 mV)	<30 ps	<120 ps	<480 ps	<1920 ps	<2000 ps	(400 mV)	<45 ps	<180 ps	<720 ps	<2880 ps	<2880 ps
	10 / 10.7G	2.5G	622M	155M	52M														
(200 mV)	<30 ps	<120 ps	<480 ps	<1920 ps	<2000 ps														
(400 mV)	<45 ps	<180 ps	<720 ps	<2880 ps	<2880 ps														
Maximum Input Power	15 dBm																		
Damage voltage	±5 V dc																		
Connector	SMA																		

Note - All specifications are nominal.

Signal Structures, Mappings and Payloads

OTN mappings

Synchronous and asynchronous mapping of 10 Gb/s SONET/SDH structured payloads is supported plus test signal and null client mappings as per ITU-T G.709. For SONET/SDH payloads, both synchronous and asynchronous mappings are supported. In asynchronous mode, the payload offset and line rate offset can be applied to the transmitted signal and measured by the instrument receiver.

SONET mappings

Bulk VT STS-1, STS-3c, 12c, 48c and 192c mappings supplied as standard.

STS-6c, 9c and 24c mappings supplied with J7231B-510

DSn/En service payload testing supplied with the J7231B-012

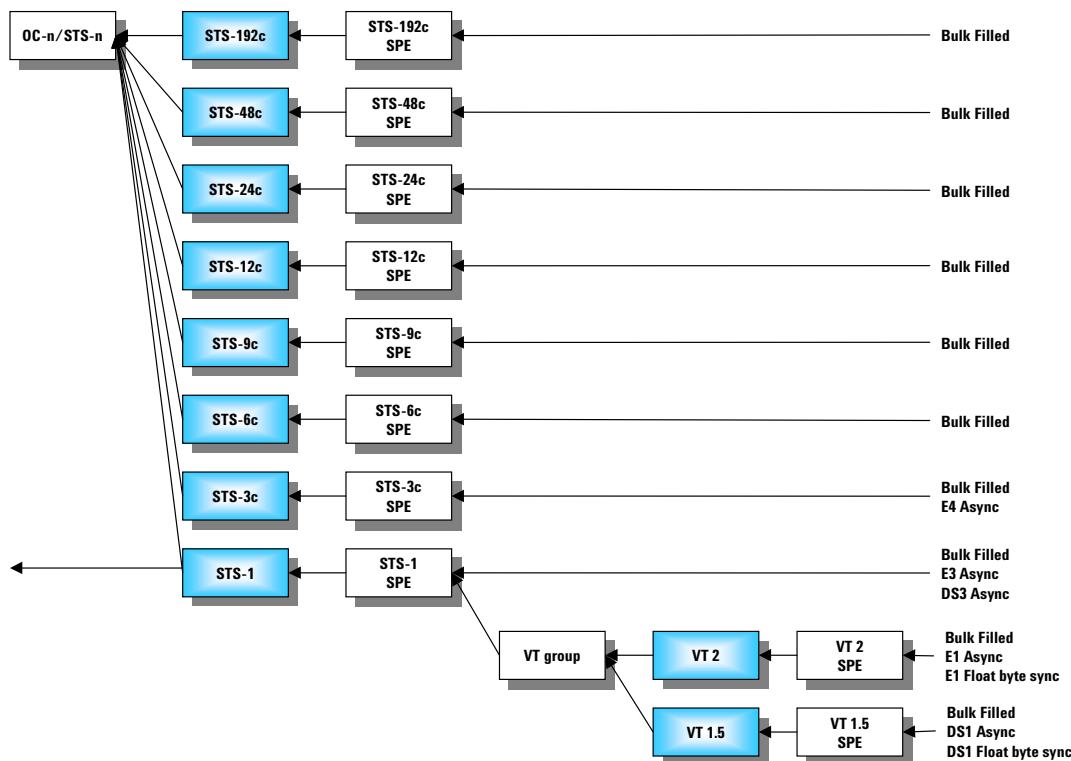

Figure 10.
SONET Mappings Supported

SDH mappings

Bulk TU C-3, C-4, C-4-4c, 16c and 64c mappings supplied as standard.

VC-4-2c, 3c and 8c mappings supplied with J7231B-510

DSn/En service payload testing supplied with the J7231B-012.

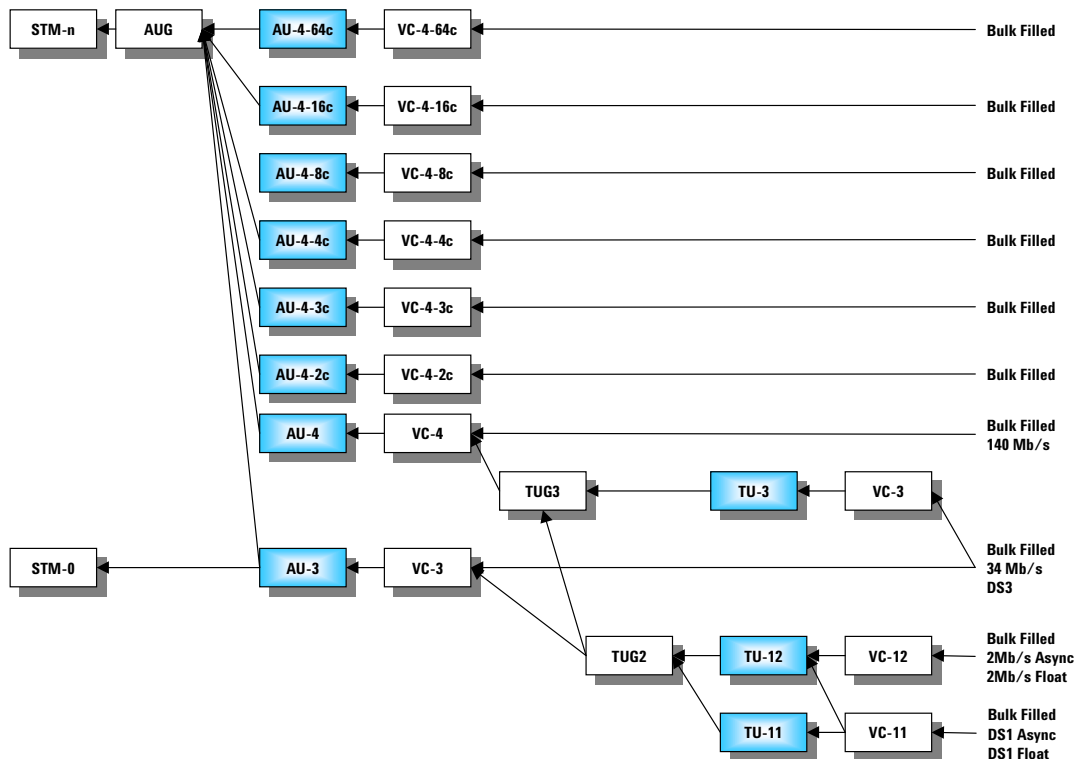

Figure 11.
SDH Mappings Supported

Mixed Mappings Generation (requires J7231B-510)

The OmniBER OTN can easily generate a SDH/SONET test signal containing any valid combination of supported AU/STS containers. An example is shown below.

With a mixed mapping configuration, one channel is selected as the foreground/test channel on the instrument transmitter. The background channels can be defined as equipped, unequipped or AU-AIS/AIS-P.

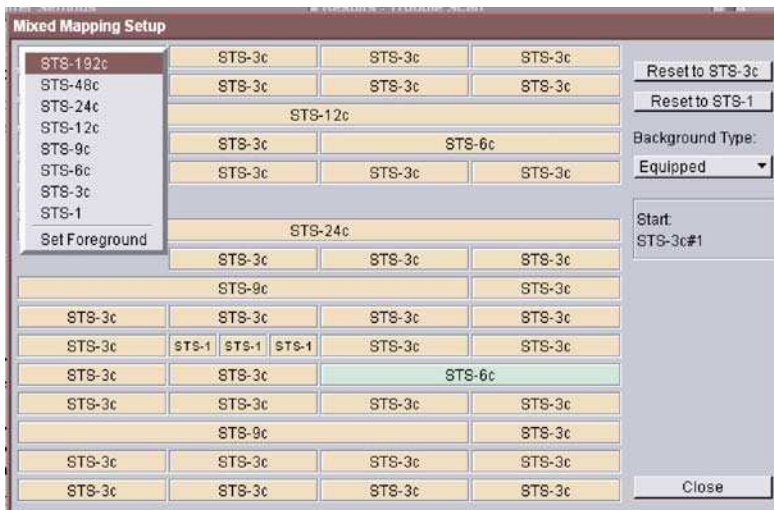

Figure 12.
Example Setup of SONET Mixed Mapping

DSn/PDH frame formats and channel structures (requires J7231B-012)

Supports generation and analysis of framed, channel structured (mux/demux) and unframed test signals.

Signal	Framing	Channel structures
DS1	SF (D4), ESF, SLC-96, no frame, bit	56 kb/s, 64 kb/s, n x 56 kb/s, n x 64 kb/s
DS3	M13, C-bit	DS1, 2 Mb/s, 56 kb/s, 64 kb/s, n x 56 kb/s, n x 64 kb/s
2 Mb/s	PCM30, PCM30CRC, PCM31, PCM31CRC	64 kb/s, n x 64 kb/s
8 Mb/s	ITU-T G.742	2 Mb/s, 64 kb/s, n x 64 kb/s
34 Mb/s	ITU-T G.751	8 Mb/s, 2 Mb/s, 64 kb/s, n x 64 kb/s
140 Mb/s	ITU-T G.751	34 Mb/s, 8 Mb/s, 2 Mb/s, 64 kb/s, n x 64 kb/s

Test patterns

PRBS	$2^9-1, 2^{11}-1^{(1)}, 2^{15}-1, 2^{20}-1^{(1)}, 2^{23}-1, 2^{31}-1^{(2)}, QRSS^{(3)}$ Polarity control: Inverted, non-inverted.
Word	All 1s, All 0s, 1010, 1000, 16-bit word. Note: Word not available in unframed mode
Notes: 1. Not provided for OTU2 or STS-192c/C-4-64c bulk payloads. 2. Not available for unscrambled OTU2 or unframed 10.71 Gb/s test signals 3. Non-inverted only. Provided for DSn & VT1.5 bulk payloads only	

Measurements

Error measurements

Measurement control	Manual, single, timed start.
Basic results	Error count, error ratio. Provided for the total measurement period and the most recent (last) measurement second.
OTN <i>(requires J7230A-112 for OTU2 measurements)</i>	OTU1/2: Frame (OA1,OA2), MFAS, SM BIP-8, SM BEI, corrected FEC errors, uncorrectable FEC blocks ODU1/2: PM BIP-8, PM BEI Payload: Bit
SONET	Transport O/H: Frame (A1,A2), CV-S (B1), CV-L (B2), REI-L (CV-LFE) Path O/H: CV-P (B3), REI-P (CV-PFE) VT: CV-V(V5), CV-VFE(REI-V) <i>(Requires J7272A-500)</i> ,. Bulk payload: Bit. Signal: BPV (STS-1 and STS-3 interfaces).
SDH	Section O/H: Frame (A1A2), B1 BIP, B2 BIP, MS-REI Path O/H: B3 BIP, HP-REI Tandem path (VC-3/4 and VC-4-Nc): IEC, TC-REI, OEI, TC-ERR LO-path: B3 (VC-3), BIP-2; LP-REI Tandem path (VC-11/12): TC-REI,OEI,N2-BIP, TC-ERR <i>(Requires J7272A-500)</i> , Bulk payload: Bit. Signal: Code (STM-0e and STM-1e interfaces).
DSn <i>(requires J7231B-012)</i>	DS1: BPV, frame, CRC6, bit. DS3: BPV, frame, P-bit, CP-bit, FEBE, bit.
PDH (En) <i>(requires J7231B-012)</i>	2 Mb/s: Code, frame, CRC4, E-bit, bit. 8Mb/s and 34 Mb/s: Code, frame, bit. 140 Mb/s: Frame, bit.
Performance analysis SONET,SDH, DSn and PDH <i>(Requires J7272A-500)</i> ,	G.826, G.828, G.821, M.2100, M.2101, M2101.1, M.2110, M.2120.

Alarm detection and measurement

Results	Alarm seconds provided for all supported alarms.
Alarm LEDs	Front panel LEDs: Red/green: Signal, frame (all levels of framing), errors (any error type), pattern. Red: OTN (any OTN alarm), SONET/SDH (any SONET/SDH alarm), DSn/PDH (any DSn or PDH alarm), history (any error/alarm event earlier in measurement period). Virtual LEDs (accesses via front panel 'Show More' key): Graphical alarm display showing status information (including history) for all supported alarm types.
OTN	Physical: LOS OTU2: LOF, OOF, OOM, LOM, AIS, IAE, BDI ODU2: AIS, OCI, LCK, BDI Payload: Pattern loss Other: Clock loss, power loss
SONET	Physical: LOS Transport O/H: LOF, SEF, J0-TIM, AIS-L, RDI-L, K1/K2 change. Path O/H: J1-TIM, AIS-P, AIS-C, LOP-P, LOP-C, RDI-P, RDI-P-P, RDI-P-C, RDI-P-S, UNEQ-P, STS pointer change, PDI-P Payload: Pattern loss. Other: Clock loss, power loss.
SDH	Physical: LOS. Section O/H: LOF, OOF, J0-TIM, MS-AIS, MS-RDI, K1/K2 change. Path O/H: J1-TIM, AU-AIS, AU-AIS-C, AU-LOP, AU-LOP-C, HP-RDI, HP-RDI-P, HP-RDI-C, HP-RDI-S, HP-UNEQ, AU pointer change LO-path: H4-LOM, TU-AIS, TU-LOP, LP-UNEQ, LP-RDI, LP-RFI, TU pointer change Tandem path (VC-3/4 and VC-4-Nc): TC-OOM, VC-AIS, TC-IAIS, TC-RDI, ODI, TC-UNEQ (VC-11/12): TC-RDI, ODI, TC-IAIS, TC-OOM, TC-UNEQ. <i>(Requires J7272A-500)</i> , Payload: Pattern loss Other: Clock loss, power loss
DSn <i>(requires J7231B-012)</i>	DS1: LOS, LOF, AIS, RAI, excess zeros, pattern loss. DS3: LOS, LOF, LOMF, AIS, RAI, idle, DS3 framing mismatch, DS2 LOF, excess zeros, pattern loss.
PDH (En) <i>(requires J7231B-012)</i>	2 Mb/s: LOS, LOF, LOMF, AIS, RDI, RDI (MF), minor alarm, pattern loss. 8 /34/140 Mb/s: LOS, LOF, AIS, RDI, minor alarm, pattern loss.

Additional measurements

Optical power	Supported for all optical receive rates. Ranges: 10/10.71 Gb/s: -3dBm to -25 dBm. 52Mb/s, 155Mb/s, 622Mb/s, 2.5 Gb/s: -3 dBm to -28 dBm. Accuracy: 10/10.71 Gb/s: ± 1.5 dB. 2.5 Gb/s: ± 2 dB. 622 Mb/s and below: ± 1 dB. Resolution: 0.1 dB.
Line frequency	Supported for all optical and electrical receive rates. Results: Frequency (Hz), Offset (Hz and ppm). Accuracy: ± 4.5 ppm Resolution: Frequency: 1 Hz (up to 622 Mb/s), 0.1 kHz (2.5 Gb/s and 10 Gb/s). Offset: 0.1 ppm.
Pointer measurements	Supported for STS/AU. VT/TU support requires J7272A-500 Results: Pointer value, increment count, decrement count, increment seconds, decrement seconds, NDF seconds, missing NDF seconds, SPE/VC offset (in ppm).
Service disruption	Measures the duration of an error burst detected in the received test pattern (not available for word patterns). Supported for OTN (with test signal mapping and SONET/SDH payload) and all SONET/SDH mappings (including concatenated). Results: Longest burst, shortest burst, last burst. Range: 50 µs to 2 s. Accuracy: ± 100 µs plus the sum of the applicable re-framing times. Resolution: 50 µs. Re-framing time (maximum): OTN: 25µs SONET/SDH: 250 µs STS/AU Pointer: 500 µs H4 multiframe (VT/TU): 1000 µs VT/TU Pointer: 2000 µs

SignalWizard (all-channel testing)
(Requires J7272A-500)

Line rates	OTN: OTU2 SONET: OC-1/3/12/48/192, STS-1/3 SDH: STM-0/1/4/16/64o, STM-0/1e
Channel sizes	Supports detection and simultaneous monitoring of any 'mix' of the following channel types: OTN: OPU2 SONET: STS-1, STS-Nc (where N = 3, 12, 48, 192). SDH: AU-3, AU-4, AU-4-Nc (where N = 4, 16, 64). Note: SignalWizard will identify STS/AU channels of any size (for example STS-24c, AU-4-8c). However, error and alarm results will only be provided for the channel types identified above.

Signal discovery and monitoring

Signal discovery and monitoring	For OTU2 signals the decoded value of the PT (payload type) byte is displayed. If the payload type is null or prbs test signal the instrument receiver is set to the appropriate test pattern. If the payload type is async or sync OC-192/STM-64, SignalWizard will determine the SONET/SDH signal structure as detailed below <ul style="list-style-type: none"> • Discovers the line rate and STS/AU channel structure of a received signal. • Monitors the line signal for: <ul style="list-style-type: none"> - CV-S (B1), CV-L (B2), CV-LFE (MS-REI) errors. - LOS, LOF, OOF, AIS-L (MS-AIS), RDI-L (MS-RDI). - Signal power/level. - Synchronization status (S1) message. - J0 section trace message. • Simultaneously monitors each STS/AU channel for: <ul style="list-style-type: none"> - CV-P (B3), CV-PFE (HP-REI) errors. - AIS-P (AU-AIS), LOP-P (AU-LOP), RDI-P (HP-RDI) alarms. - Payload mapping type (C2 signal label). - Pointer activity. - J1 path trace message. • Discovery and simultaneous monitor of all VT/TU channels in a selected STS/AU for: <ul style="list-style-type: none"> - CV-V (BIP-2), CV-VFE (LP-REI) errors. - AIS-V (TU-AIS), LOP-V (TU-LOP), RFI-V (LP-RFI), RDI-V (LP-RDI) alarms. - Payload mapping type (V5 signal label). - Pointer activity. - J2 path trace message.
--	--

STS/AU channel viewer display

STS/AU channel viewer display	Results are clearly presented on a colour-coded graphical display that shows: <ul style="list-style-type: none"> • Line rate and power/level of the received signal. • Status indicators (including history) for each line/section error and alarm. • Text decode of synchronization status (S1) and J0 section trace. • For each STS/AU channels: <ul style="list-style-type: none"> - Channel size and channel traffic information (equipped/unequipped and channels carrying VT/TU payloads). - Aggregated error/alarm status (including history) and pointer activity. • For a selected STS/AU channel: <ul style="list-style-type: none"> - Status indicators (including history) for each channel error/alarm. - Pointer activity. - The payload mapping being carried (C2 signal label decode). - J1 path trace message. • For each VT/TU channel in a selected STS/AU: <ul style="list-style-type: none"> - Channel size and channel traffic information (equipped/unequipped). - Aggregated error/alarm status (including history) and pointer activity. • For a selected VT/TU channel: <ul style="list-style-type: none"> - Status indicators (including history) for each channel error and alarm. - The payload mapping being carried (V5 signal label decode). - Pointer activity. • J2 path trace message.
--------------------------------------	--

<p>Path routing test facilities</p>	<p>Overview of received path trace messages:</p> <ul style="list-style-type: none"> • Tabular display showing the J1 path trace message associated with each STS/AU channel in the received line signal. • Tabular display showing the J2 path trace message associated with each VT/TU channel in a selected STS/AU. <p>Search for specified path trace message:</p> <ul style="list-style-type: none"> • Identifies channel that is carrying a user-specified path trace message. • For J1 messages, the search is performed on all STS/AU channels in received signal. • J2 message search is performed on: <ul style="list-style-type: none"> - All VT/TU channels in a selected STS/AU channel. - All VT/TU channels in all STS/AU channels. • Search can be performed using any sub-string contained in the target path trace message. Search results report up to 25 matches.
<p>Channel traffic overview</p>	<p>Tabular display that lists for each STS/AU channel in the received signal:</p> <ul style="list-style-type: none"> • Channel number. • Channel size/type. • The payload mapping being carried. • J1 path trace message. <p>Tabular display that lists for each VT/TU channel in a selected STS/AU:</p> <ul style="list-style-type: none"> • Channel number. • Channel size/type. • The payload mapping being carried • J2 path trace message.

Error and Alarm Generation

Error generation

<p>OTN</p>	<p>Physical: Entire frame ⁽¹⁾</p> <p>OTU2: Frame (OA1,OA2), MFAS, BIP-8, BEI, correctable FEC errors, uncorrectable FEC blocks</p> <p>ODU2: BIP-8, BEI</p> <p>Payload: Bit</p> <p>Error control: Single, error all⁽³⁾, M.P x 10⁻ⁿ (where M.P = 0.1 to 9.9 in 0.1 steps; n = 3 to 9)⁽⁴⁾,</p>
<p>SONET</p>	<p>Physical: Entire frame ⁽¹⁾</p> <p>Transport O/H: Frame (A1A2), CV-S (B1), CV-L (B2), REI-L (CV-LFE)⁽²⁾</p> <p>Path O/H: CV-P (B3), REI-P (CV-PFE)</p> <p>VT path: CV-V (V5), CV-VFE (REI-V). (Requires J7272A-500),</p> <p>Signal: BPV (STS-1).</p> <p>DSn/En payload: See DSn and PDH (En) error add for details.</p> <p>Bulk payload: Bit.</p> <p>Error Control: Single, error all⁽³⁾, M.P x 10⁻ⁿ (where M.P = 0.1 to 9.9 in 0.1 steps; n = 3 to 9)⁽⁴⁾, N-in-4⁽⁵⁾, N-in-T⁽⁶⁾.</p>

<p>SDH</p>	<p>Physical: Entire frame ⁽¹⁾</p> <p>Section O/H: Frame (A1A2), B1 BIP, B2 BIP, MS-REI.⁽²⁾</p> <p>Path O/H: B3 BIP, HP-REI</p> <p>LO-path: B3 (VC-3), BIP-2 (VC-1/2); LP-REI. (Requires J7272A-500)</p> <p>Tandem path (VC-3/4 and VC-4-Nc): IEC, TC-REI, OEI. (VC-11/12): TC-REI, TC-OEI, N2-BIP. (Requires J7272A-500),</p> <p>PDH/DSn payload: See PDH and DSn error add for details.</p> <p>Bulk payload: Bit.</p> <p>Error Control: Single, Error All ⁽³⁾, M.P x 10⁻ⁿ (where M.P = 0.1 to 9.9 in 0.1 steps; n = 3 to 9)⁽⁴⁾, N-in-4 ⁽⁵⁾, N-in-T ⁽⁶⁾⁽⁷⁾</p>
<p>DSn (requires J7231B-012)</p>	<p>DS1: BPV⁽⁸⁾, excess zeros⁽⁹⁾, frame, CRC6, bit.</p> <p>DS3: BPV ⁽⁸⁾, excess zeros⁽⁹⁾, frame, MFAS, P-bit, CP-bit, FEBE, bit.</p> <p>Error control: Single, M.P x 10⁻ⁿ (where M.P = 0.1 to 9.9 in 0.1 steps, and n = 3 to 9)⁽⁴⁾, N-in-4⁽¹⁰⁾, N-in-6⁽¹¹⁾</p>
<p>PDH (En) (requires J7231B-012)</p>	<p>2 Mb/s: Code⁽⁸⁾, frame, CRC4, E-bit, bit.</p> <p>8 Mb/s and 34 Mb/s: Code⁽⁸⁾, frame, bit.</p> <p>140 Mb/s: frame, bit.</p> <p>Error control: Single, M.P x 10⁻ⁿ (where M.P = 0.1 to 9.9 in 0.1 steps, and n = 3 to 9)⁽⁴⁾, N-in-4⁽¹⁰⁾.</p>

Notes:

1. Errors added after scrambling (and also after FEC calculation for OTN) to simulate transmission errors
2. For OC-192/STM-64, supports both the 'M1 only' and 'M0+M1' options of the standards.
3. Not supported for data, frame, MFAS BPV/code, FEC block or bit.
4. The maximum error rate for any error type is 1×10^{-3} or the maximum error rate supported by the error type (its saturation value), whichever is the lower.
5. Supported for frame (A1A2) errors. N = 1 to 4.
6. SONET: B2 errors only. N errors transmitted during time T (T = 10 ms to 1000 s in decade steps; N = 0 to 640 x n errors, where n is the hierarchical level of the STS-n/OC-n signal).
7. SDH: B2 errors only. N errors transmitted during time T (T = 10 ms to 1000 s in decade steps; N = 0 to 640 errors for STM-0, and 0 to 1920 x n errors for all other line rates, where n is the hierarchical level of the STM-n signal).
8. Not available when signal is a mapped payload in SONET/SDH or a channel within a higher rate DSn/PDH signal.
9. Single burst of 3 to 16 zeros (user selectable) transmitted without line coding.
10. Supported for DS3 frame, DS3 MFAS and PDH frame errors. N = 1 to 4.
11. Supported for DS1 frame errors. N = 1 to 6.

Alarm generation		Overhead Monitor
Alarm control	<p>On/Off/Stress</p> <p>On/Off: The alarm is turned on or off</p> <p>Stress sequence (Requires J7272A-500): Performed using a 'p', 'n' and 'm' sequence. With alarm initial condition ON (OFF), the alarm is toggled OFF (ON) for 'p' frames followed by a continuous repeat of 'n' frames ON (OFF) then 'm' frames OFF (ON). The values of p, n and m can be changed hitlessly during testing.</p> <p>Pulse (Requires J7272A-500): The alarm condition can be transmitted for a user defined number of consecutive frames.</p> <p>Single (Requires J7272A-500): OOF only - A single instance of OOF generated as per ITU-T /Telcordia recommendations</p> <p>Note: Stress testing available for OTN, SONET and SDH alarm testing, excluding VT/TU alarms. LOS stress test only available at 10/10.71 Gb/s</p>	<p>Displays all received OTU, ODU and OPU overhead bytes in hexadecimal format. Values are updated approximately every second.</p>
OTN	<p>Physical: LOS</p> <p>OTU2: LOF, OOF, OOM, AIS, IAE, BDI</p> <p>ODU2: AIS, OCI, LCK, BDI</p>	Overhead Sequence Generation
SONET	<p>Physical: LOS.</p> <p>Transport O/H: LOF, SEF, J0-TIM, AIS-L, RDI-L.</p> <p>Path O/H: J1-TIM, AIS-P, LOP-P, RDI-P, RDI-P-P, RDI-P-S, RDI-P-C, UNEQ-P.</p> <p>VT path: H4-LOM, AIS-V, LOP-V, RDI-V, RDI-V-P, RDI-V-S, RDI-V-C, RFI-V, UNEQ-V. (Requires J7272A-500),</p>	<p>A single overhead channel can be chosen to have a sequence of hexadecimal values inserted. 256 different elements for the sequence can be defined, each element being the appropriate number of bytes for the selected overhead channel. Each element can be transmitted for a variable number of frames (1-65535). This sequence can be transmitted as a single run or repeated indefinitely.</p> <p>Sequence Channels: 6 Bytes: FAS 4 Bytes: APS/PCC 2 Bytes: GCC0-2, EXP 1 Byte: MFAS, TCM ACT, FTFL, RES, PM bytes 1 and 3, SM bytes 1 and 3, TCM 1-6 bytes 1 and 3, OPU2 bytes (excluding JC, NJO and PJO when in async mode)For TCM1-6, bytes 1 and 3 can be sequenced, the BIP-8 is calculated.</p> <p>Overhead sequences will be automatically synchronized to the MFAS if the number of frames in the sequence is a multiple or sub-multiple of 256 (e.g. 64, 128 or 512 frames).</p>
SDH	<p>Physical: LOS.</p> <p>Section O/H: LOF, OOF, J0-TIM, MS-AIS, MS-RDI.</p> <p>Path O/H: J1-TIM, AU-AIS, AU-LOP, HP-RDI, HP-RDI-P, HP-RDI-C, HP-RDI-S, HP-UNEQ.</p> <p>LO-path: H4-LOM, TU-AIS, TU-LOP, LP-RDI, LP-RFI, LP-UNEQ.</p> <p>Tandem path: (VC-3/4 and VC-4-Nc): TC-OOM, VC-AIS, TC-IAIS, TC-RDI, ODI, TC-UNEQ.(VC-11/12): TC-RDI, TC-ODI, VC-AIS, TC-UNEQ. (Requires J7272A-500),</p>	Overhead Sequence Capture
DSn (requires J7231B-012)	<p>DS1: LOS, LOF, AIS, RAI.</p> <p>DS3: LOS, LOF, AIS, RAI, idle.</p>	<p>A single overhead channel can be selected for capture. 256 unique values of the selected channel are displayed along with the number of frames (1-65535) for which each value has persisted.</p> <p>Sequence Channels: 6 Bytes: FAS (OA1, OA2) 4 Bytes: APC/PCC 2 Bytes: GCC0, TCM TOS, EXP, GCC1, GCC2 1 Byte: MFAS, TCM ACT, FTFL, RES, PM bytes 1 and 3, SM bytes 1 and 3, TCM 1-6 bytes 1 and 3, OPU2 bytes (not JC, NJO, PJO in async mode)</p> <p>Trigger value: User definable Capture is triggered when user defined value is</p> <ul style="list-style-type: none"> Equal to the received value in the selected channel or NOT equal to the received value in the selected channel <p>Trigger Mask: Trigger mask value settable by user. Only bits corresponding to a '1' in the mask value are used to detect trigger.</p> <p>Trigger Selection:</p> <ul style="list-style-type: none"> Manual. 256 values following the manual capture are displayed. Pre trigger capture. Up to 256 values up to and including the trigger point are displayed. Capture is triggered as soon as possible after the capture is started, even if 256 values have not been captured. Post trigger capture. Up to 256 values including and following the trigger point are displayed. The captured data is updated every second after the capture has triggered. Centred capture. Up to 128 values before the trigger point and up to 128 values including and following the trigger point are displayed.
PDH (En) (requires J7231B-012)	<p>2 Mb/s: LOS, LOF, LOMF, AIS, RDI, RDI (MF), minor alarm.</p> <p>8 /34/140 Mb/s: LOS, LOF, AIS, RDI, minor alarm.</p>	
OTN, SONET and SDH Overhead Testing		
OTN Overhead Testing		
Overhead Setup	<p>Overhead bytes are user programmable in hexadecimal. Trace identifier messages are settable in ASCII.</p> <p>Restrictions: SM BIP-8 and PM BIP-8 are calculated values. Control of these bytes is achieved using the instrument error generation feature. No access to JC, NJO or PJO.</p>	

<p>Frame Capture</p>	<p>Four complete optical channel frames including overhead, payload and FEC blocks can be captured for display and analysis.</p> <p>Frame Capture Triggers: Trigger Selection:</p> <ul style="list-style-type: none"> • Manual - Four frames after the manual trigger are captured. • Pre-trigger - Four frames up to and including the trigger frame are captured. • Post-trigger - The trigger frame plus three following frames are captured. • Centered - Two frames before the trigger frame, the trigger frame and the next frame are captured. <p>Capture Triggers: Frame capture can be triggered on receive triggers as detailed in "Event Trigger Outputs".</p>	<p>Overhead Sequence Capture</p> <p>A single overhead channel can be selected for capture. 256 unique values of the selected channel are displayed along with the number of frames (1-65535) for which each value has persisted.</p> <p>Sequence Channels: 9 Bytes: D4-D12 6 Bytes: A1,A2 for STM-1 to 64 and STS-3 to 192 3 Bytes: D1-D3 2 Bytes: A1,A2 for STM-0 or STS-1, M0-M1 (STM-64 only), K1-K2, H1-H2 1 Byte: J0, E1, F1, S1, M1, Z0, J1, C2, G1, F2, H4, F3, K3, N1, H3</p> <p>Trigger value: User definable Capture is triggered when user defined value is</p> <ul style="list-style-type: none"> • Equal to the received value in the selected channel or • NOT equal to the received value in the selected channel <p>Trigger Mask: Trigger mask value settable by user. Only bits corresponding to a '1' in the mask value are used to detect trigger.</p> <p>Trigger Selection:</p> <ul style="list-style-type: none"> • Manual. 256 values following the manual capture are displayed. • Pre trigger capture. Up to 256 values up to and including the trigger point are displayed. Capture is triggered as soon as possible after the capture is started, even if 256 values have not been captured. • Post trigger capture. Up to 256 values including and following the trigger point are displayed. The captured data is updated every second after the capture has triggered. • Centred capture. Up to 128 values before the trigger point and up to 128 values including and following the trigger point are displayed. 	<p>A single overhead channel can be selected for capture. 256 unique values of the selected channel are displayed along with the number of frames (1-65535) for which each value has persisted.</p> <p>Sequence Channels: 9 Bytes: D4-D12 6 Bytes: A1,A2 for STM-1 to 64 and STS-3 to 192 3 Bytes: D1-D3 2 Bytes: A1,A2 for STM-0 or STS-1, M0-M1 (STM-64 only), K1-K2, H1-H2 1 Byte: J0, E1, F1, S1, M1, Z0, J1, C2, G1, F2, H4, F3, K3, N1, H3</p> <p>Trigger value: User definable Capture is triggered when user defined value is</p> <ul style="list-style-type: none"> • Equal to the received value in the selected channel or • NOT equal to the received value in the selected channel <p>Trigger Mask: Trigger mask value settable by user. Only bits corresponding to a '1' in the mask value are used to detect trigger.</p> <p>Trigger Selection:</p> <ul style="list-style-type: none"> • Manual. 256 values following the manual capture are displayed. • Pre trigger capture. Up to 256 values up to and including the trigger point are displayed. Capture is triggered as soon as possible after the capture is started, even if 256 values have not been captured. • Post trigger capture. Up to 256 values including and following the trigger point are displayed. The captured data is updated every second after the capture has triggered. • Centred capture. Up to 128 values before the trigger point and up to 128 values including and following the trigger point are displayed.
<p>Trail Trace Identifiers</p>	<p>Text based set-up and monitoring of the SM and PM TTI message</p>	<p>Entire Overhead Capture</p> <p>6 complete frames of overhead are captured.</p> <p>Overhead selection:</p> <ul style="list-style-type: none"> • SOH+LOH / RSOH+MSOH or • STS/POH <p>Trigger selection:</p> <ul style="list-style-type: none"> • Manual - 6 frames after the manual trigger are captured • Pre-trigger - 6 frames up to and including the trigger frame are captured • Post-trigger - The trigger frame plus 5 following frames are captured • Centered - 3 frames before the trigger frame, the trigger frame and the next 2 frames are captured <p>Capture Triggers: Entire overhead capture can be triggered on receive triggers as detailed in "Event Trigger Outputs"</p>	<p>6 complete frames of overhead are captured.</p> <p>Overhead selection:</p> <ul style="list-style-type: none"> • SOH+LOH / RSOH+MSOH or • STS/POH <p>Trigger selection:</p> <ul style="list-style-type: none"> • Manual - 6 frames after the manual trigger are captured • Pre-trigger - 6 frames up to and including the trigger frame are captured • Post-trigger - The trigger frame plus 5 following frames are captured • Centered - 3 frames before the trigger frame, the trigger frame and the next 2 frames are captured <p>Capture Triggers: Entire overhead capture can be triggered on receive triggers as detailed in "Event Trigger Outputs"</p>
<p>SONET/SDH overhead testing</p>		<p>APS/MSP messages (K1K2)</p> <p>Text-based setup and monitoring of APS/MSP messages.</p> <p>Linear: Messages comply with Telcordia GR-253-CORE Issue 3 and ITU-T G.783.</p> <p>Ring: Messages comply with Telcordia GR-1230 and ITU-T G.841.</p>	<p>Text-based setup and monitoring of APS/MSP messages.</p> <p>Linear: Messages comply with Telcordia GR-253-CORE Issue 3 and ITU-T G.783.</p> <p>Ring: Messages comply with Telcordia GR-1230 and ITU-T G.841.</p>
<p>Overhead set-up</p>	<p>All TOH/SOH, STS-path/HO-path overhead bytes user programmable in hexadecimal.</p> <p>Restrictions: B1, B2, B3, H1 (SS-bits programmable), H2, H3, V1 to V4, V5 (Bits 5-7 programmable).</p>	<p>APS/MSP messages (K1K2)</p> <p>Text-based setup and monitoring of APS/MSP messages.</p> <p>Linear: Messages comply with Telcordia GR-253-CORE Issue 3 and ITU-T G.783.</p> <p>Ring: Messages comply with Telcordia GR-1230 and ITU-T G.841.</p>	<p>Text-based setup and monitoring of APS/MSP messages.</p> <p>Linear: Messages comply with Telcordia GR-253-CORE Issue 3 and ITU-T G.783.</p> <p>Ring: Messages comply with Telcordia GR-1230 and ITU-T G.841.</p>
<p>Overhead monitor</p>	<p>Displays all TOH/SOH overhead bytes in a selected STS-3/STM-1group, plus all STS-path/HO-path overhead bytes. Received byte values are presented in hexadecimal.</p>		
<p>Overhead Sequence Generation</p>	<p>A single overhead channel can be chosen to have a sequence of hexadecimal values inserted. 256 different elements for the sequence can be defined, each element being the appropriate number of bytes for the selected overhead channel. Each element can be transmitted for a variable number of frames (1-65535). This sequence can be transmitted as a single run or repeated indefinitely.</p> <p>Sequence Channels: 9 Bytes: D4-D12 6 Bytes: A1,A2 for STM-1 to 64 and STS-3 to 192 3 Bytes: D1-D3 2 Bytes: A1,A2 for STM-0 or STS-1, M0-M1 (STM-64 only), K1-K2, H1-H2 1 Byte: J0, E1, F1, Z0, J1, C2, G1, F2, H4, F3, K3, N1, H3</p>		

Active APS Test	<p>The ACTIVE APS message test gives real-time K1/K2 response to provide switching keep-alive capability. The instrument will not initiate any K1/K2 changes, but will respond to change requests that appear on the input K1/K2 byte values. The K1/K2 response is sent if the received value persists for 3 frames.</p> <p>Note: Only available when 1:N architecture is selected</p> <p>Operating Modes:</p> <ul style="list-style-type: none"> • Unidirectional • Bidirectional <p>Emulation response time: 10ms</p>
Trace messages (J0, J1, J2, TC-APId)	<p>Text-based set-up and monitoring of all trace messages (J0, J1, J2, TC-APId (VC-3/4, VC-4-Nc).</p> <p>Message formats: J0/J1/J2: Selectable as 16-byte or 64-byte format. TC-APId (SDH only): 16-byte format.</p> <p>Trace Identifier Mismatch Alarm (TIM) <i>(Requires J7272A-500)</i> Generation and detection of J0 and J1 TIM</p>
Synchronization status message (S1)	<p>Text-based set-up and monitoring of Synchronization Status messages. Messages comply with Telcordia GR-253-CORE Issue 3 and ITU-T G.707 (04/00 draft).</p>
Signal labels (C2, V5)	<p>Text-based set-up and monitoring of payload signal labels (both STS path/HO-path. Signal labels comply with Telcordia GR-253-CORE Issue 3 and ITU-T G.707 (04/00 draft).</p>

SONET/SDH pointer adjustment control

The following pointer adjustment controls are provided as standard for STS-Nc/AU-4-Nc and STS/AU payload pointers.

New pointer	<p>Transmits a new pointer address with or without a new data flag (NDF). Supports setting of any valid pointer value.</p>
Burst	<p>Single burst of adjustments transmitted in a selected pointer.</p> <p>Adjustment polarity: Incrementing, decrementing, alternating.</p> <p>Burst size: STS/AU and STS-Nc/AU-4-Nc: 1 to 10.</p> <p>Separation of adjustments in burst: STS/AU and STS-Nc/AU-4-Nc: 4 frames (500µs).</p>
Periodic sequence	<p>Periodic sequence of pointer adjustments created by generating a frequency offset between the line and SPE/VC clocks.</p> <p>Clock control: User selectable as either: 1. SPE/VC clock offset, line clock locked to reference. 2. Line clock offset, SPE/VC clock locked to reference.</p> <p>Offset: User selectable in the range ± 100 ppm.</p> <p>Setting resolution: 0.1 ppm.</p> <p>Accuracy: 0.02 ppm.</p>

SONET/SDH pointer adjustment control

OTN transmit triggers	<p>Source: LOS - available with alarm stress 'Pulse' mode</p> <p>OTU2: LOF, OOF, LOM, OOM, AIS, IAE, BDI,</p> <p>ODU2: AIS, OCI, LCK, BDI,</p> <p>Format: Level</p> <p>Source: Start of frame, entire frame error add, frame error (OA1,OA2), MFAS</p> <p>OTU2: BIP8, BEI</p> <p>ODU2: SM BIP8, SM BEI, FEC Block error, bit</p> <p>Format: Pulse</p>
OTN receive triggers	<p>Source:</p> <p>OTU2: LOF, OOF, AIS, IAE, BDI</p> <p>ODU2: AIS, OCI, LCK, BDI</p> <p>Format: Level</p> <p>Source: Start of frame, frame error (OA1,OA2), MFAS</p> <p>OTU2: BIP8, BEI</p> <p>ODU2: BIP8, BEI FEC Block error</p> <p>Format: Pulse</p> <p>Note: All of the above triggers are selectable for frame capture</p>
SONET transmit triggers	<p>Physical: LOS - available with alarm stress 'Pulse' mode</p> <p>Transport O/H: LOF, SEF, AIS-L, RDI-L</p> <p>Path O/H: AIS-P, AIS-C, LOP-P, LOP-C, RDI-P, UNEQ-P,</p> <p>Format: Level</p> <p>Transport O/H: Start of frame, entire frame error add, frame error (A1,A2), CV-S(B1), CV-L(B2), REI-L (CV-LFE)</p> <p>Path O/H: CV-P(B3), REI-P (CV-PFE)</p> <p>Payload: Bit</p> <p>Format: Pulse</p>
SONET receive triggers	<p>Transport O/H: LOF*, SEF*, AIS-L, RDI-L</p> <p>Path O/H: LOP-P**, LOP-C**, AIS-P**, AIS-C**, RDI-P, UNEQ-P</p> <p>Format: Level</p> <p>Transport O/H: Start of frame, frame error, CV-S(B1), CV-L(B2), REI-L(CV-LFE), STS pointer change, K1/K2 change</p> <p>Path O/H: CV-P(B3), REI-P (CV-PFE)</p> <p>Format: Pulse</p> <p>Note: TOH event triggers are selectable for TOH frame capture. STS event triggers are selectable for STS-Path capture. * Trigger not available at OC-48 rate **Trigger not available for Entire Overhead Capture</p>

SDH transmit triggers	<p>Physical: LOS- available with alarm stress 'Pulse' mode</p> <p>Section O/H: LOF, OOF, MS-AIS, MS-RDI,</p> <p>Path O/H: AU-AIS, AU-AIS-C, AU-LOP, AU-LOP-C, HP-RDI, HP-UNEQ</p> <p>Tandem path: TC-OOM, VC-AIS, TC-IAIS, TC-RDI, ODI, TC-UNEQ</p> <p>Format: Level</p> <p>Section O/H: Start of frame, entire frame error add, frame error (A1,A2), B1 BIP, B2 BIP, MS-REI</p> <p>Path O/H: B3 BIP, HP-REI</p> <p>Tandem Path: IEC, TC-REI, OEI</p> <p>Payload: bit</p> <p>Format: Pulse</p>
SDH receive triggers	<p>Section O/H: LOF*, OOF*, MS-AIS, MS-RDI</p> <p>Path O/H: AU-AIS**, AU-AIS-C**, AU-LOP**, AU-LOP-C**, HP-RDI, HP-UNEQ</p> <p>Tandem Path: TC-OOM, VC-AIS, TC-IAIS, TC-RDI, ODI, TC-UNEQ</p> <p>Format: Level</p> <p>Section O/H: Start of frame, frame error (A1,A2), B1 BIP, B2 BIP, MS-REI, , AU-3/4 pointer change, K1/K2 change</p> <p>Path O/H: B3 BIP, HP-REI</p> <p>Tandem Path: IEC, TC-REI, OEI, TC-ERR</p> <p>Format: Pulse</p> <p>Note: RSOH and MSOH event triggers are selectable for RSOH+MSOH frame capture. POH event triggers are selectable for POH capture. * Trigger not available at STM-16 rate ** Trigger not available for Entire Overhead Capture</p>

Tx and Rx Trigger Output Ports for OTN/SONET/SDH

Connectors	SMA, TTL, 50Ω
Output level	Logic '1' = 4V typical Logic '0' = 0V typical
Pulse Width	100ns Nominal

GCC/DCC Drop/Insert

Supports the drop and insert of DCC channels from SONET/SDH or GCC channels from OTN signals

Connector	9-pin miniature D-type.
Rates	D1-D3 DCC channel: 192 kb/s. D4-D12 DCC channel: 576 kb/s. GCC0, 1, 2 channels: 1.3124 Mb/s
Signal type	Unipolar differential type designed to be similar to TIA/EIA-422-B and ITU Recommendation V.11 with reduced common-mode voltage range due to reduced supply voltage of 3.3V.
Input termination	100Ω differential.
Input sensitivity	200mV over a common-mode input voltage range from -0.3V to 5.5V.

Output voltage swing	>0.95V (1.5V typical)
DC Levels	Logic '1' = 2.3V typical, 1.85V min Logic '0' = 0.8V typical, 1.05V max
Order of transmission	Most significant bit (MSB) transmitted first (for both data input and data output).

GCC/DCC drop/insert connector pin-out

Pin number	RS-449/422 signal
1	Rx data output (+)
2	Rx clock output (+)
3	Signal ground
4	Tx clock output (+)
5	Tx data input (+)
6	Rx data output (-)
7	Rx clock output (-)
8	Tx clock output (-)
9	Tx data input (-)

Payload Drop/Insert capabilities (requires J7231B-012)

DSn/PDH to/from SONET	Supports the external drop/insert of asynchronous mapped DSn/PDH payloads. Drop/insert is performed via the instrument's DSn/PDH electrical test ports. Supported rates: DS1, E1 (2Mb/s), DS3.
DSn/PDH to/from SDH	Supports the external drop/insert of asynchronous mapped DSn/PDH payloads. Drop/insert performed via the instrument's DSn/PDH electrical test ports. Supported rates: DS1, 2 Mb/s, 34 Mb/s, DS3, 140 Mb/s.
DSn/PDH to/from DSn/PDH	Supports the external drop/insert of a DS1 or 2 Mb/s channel to/from a higher-rate DSn/PDH signal. Drop-insert performed via the instrument's DSn/PDH electrical test ports. Supported rates: DS1 to/from DS3; 2 Mb/s(1) to/from 8/34/140 Mb/s or DS3.
Voice drop	Allows the traffic in a selected 56 kb/s or 64 kb/s timeslot carried within a DS1 or 2 Mb/s signal to be dropped to an internal speaker. The DS1 or 2 Mb/s signal can be at the primary signal rate or carried within a higher-rate line signal (SONET/SDH or DS3/PDH). Coding: A-law (2 Mb/s), m-law (DS1).

Note: 2 Mb/s drop/insert to/from an 8/34/140 Mb/s signal is performed via the 120Ω balanced test ports (3-pin Siemens connectors)

Thru-mode testing

OTN	<p>Rate: OTU2</p> <p>Transparent: Receive signal passes unaltered through test set. All receiver test facilities are available.</p>
SONET/SDH	<p>Rates: SONET: OC-1, OC-3, OC-12, OC-48, OC-192, STS-1*, STS-3*. SDH: STM-0o, STM-1o, STM-4o, STM-16o, STM-64o, STM-0e*, STM-1e*. <i>* Requires option 104 or 105 or 106</i></p> <p>Transparent: Receive signal passes unaltered through test set. All receiver test facilities are available.</p> <p>Overhead Overwrite (Requires J7272A-500): Error and alarm events down to high order path level as detailed in sections "Error Generation" and "Alarm Generation" DCC drop/insert Trace messages (J0, J1) Labels (S1, C2) APS Messages (K1,K2) Entire frame error add A1/A2 error add</p>
DSn <i>(requires J7231B-012)</i>	<p>Receive signal passes unaltered through test set. All receiver test facilities are available.</p> <p>Rates: DS1, DS3.</p>

DSn/PDH Testing (requires J7231B-012)

DS1 loopcodes and DS3 FEAC messages

DS1 loopcodes	<p>Transmits and monitors both in-band and out-of-band DS1 loopcodes.</p> <p>In-band: Line, payload, network, user (selectable in range 3 to 8 bits). Transmit: Selected code transmitted for 8 seconds (nominal). Monitor: Indicates the detection of a selected loop-up and loop-down code. Displays the last valid loopcode received.</p> <p>Out-of-band: Line, payload, network, universal, user (11111111 0xxxxxx0). Transmit: Selected code transmitted either continuously or in a burst of n-messages (where n is selectable in the range 1 to 15). Monitor: Displays in decode form the two most recently received loopcodes (current and previous).</p>
DS3 FEAC messages	<p>Applies to DS3 C-bit framed signals. Transmits and monitors loopback and alarm/status codes as per ANSI T1.107-1995.</p> <p>Loopback code transmit: Transmits any user selected loopback code as a single burst of 'N loopback codes' and 'M messages' (where N and M are selectable in the range 1 to 15).</p> <p>Alarm/status code transmit: Transmits any ANSI T1.107-1995 message or any user specified code (0xxxxxx0 11111111), either continuously or in a single burst (selectable in the range 1 to 15).</p> <p>Monitor: Displays in decoded form the two most recently received FEAC messages (current and previous).</p>

PDH spare-bits testing

Supports user-programming and monitoring of PDH frame spare-bits.

2 Mb/s (non-CRC framing)	Si-bit (timeslot 0, bit 1); Sa4 to Sa8 (NFAS timeslot); timeslot 16 (MFAS) bits 5, 7 and 8 (PCM30 framing).
2 Mb/s (CRC framing)	E-bits (Si-bit in frames 13 and 15); 8-bit pattern in each NFAS Sa-bit (Sa4 to Sa8); timeslot 16 (MFAS) bits 5, 7 and 8 (PCM30CRC framing).
8/34/140 Mb/s	8 Mb/s and 34 Mb/s: FAS bit 12. 140 Mb/s: FAS bits 14 to 16.

Signaling-bits testing

2 Mb/s	<p>Framing formats: PCM30, PCM30CRC (CAS). Transmit: User-programmed value transmitted in ABCD signaling-bits associated with all 30-channels. Monitor: Displays ABCD signaling-bits associated with all 30-channels.</p>
DS1	<p>Frame formats: SF (D4), ESF, SLC-96 Channel type: 56 kb/s structured timeslots. Transmit: User-programmed value transmitted in AB or ABCD signaling-bits associated with all 24-channels. Monitor: Displays AB or ABCD signaling-bits associated with all 24-channels.</p>

Additional features	
Help facilities	<p>On-line user documentation: Accessed via front panel key.</p> <p>Context-sensitive help: Provided for each control-field on a dedicated line of the instrument's display. The displayed help information automatically tracks the cursor.</p> <p>User-help documentation: Supports the installation (from floppy disk) of up to 1.44 Mbytes of user-authored help files in the instrument's non-volatile memory. This help information is available in addition to that provided as standard.</p>
Stored configurations	Provides storage for five instrument configurations (one factory-default configuration plus four user configurations) in non-volatile memory. Additional instrument configurations can be saved to and recalled from the floppy disk.
Graphical results	<p>The following graphical results are available for display during a measurement:</p> <p>STS/AU pointer: Line graph of STS/AU pointer value vs time.</p> <p>Optical Power: Line graph of optical power vs time</p> <p>Errors: Bar graph for each supported error types vs time.</p> <p>Alarms: Line graph for each supported alarm type vs time.</p> <p>VT/TU pointer: Line graph of VT/TU pointer address vs time.</p> <p>Time resolution: 1-second.</p> <p>Storage: Up to 10 sets (or 10 Mbytes in total) of graphical results can be saved in the instrument's non-volatile memory.</p>
Result logging	<p>Supports logging of results during a measurement to a printer, to a file in the instrument's non-volatile memory or to floppy disk.</p> <p>Logged information: Instrument settings, time and date, period-results, end-of-measurement results (the results logged are user selectable).</p> <p>Logging period: 10-minutes, 1-hour, 24-hours, user-defined (in ranges 10 to 99-minutes; 1 to 99-hours).</p>
Printing	Supports printing of logged results and screen dumps via USB port.
Beep-on-error	<p>Audible beep emitted on detection of any valid error-type.</p> <p>Control: Off/on (with user controlled volume).</p>
General specifications	
Display	8.4" VGA display (TFT active matrix).
Floppy disk	<p>1.44 Mb IBM-compatible. Supported facilities include:</p> <p>Stored configurations: Save and recall of instrument configurations.</p> <p>Logged results: Saving the results generated during measurement logging. Results saved in Windows®-compatible 'plain text' format.</p> <p>Screen dumps: Saving the current instrument display in Windows-compatible .BMP format.</p> <p>User-help files: Downloading user-help files to the instrument.</p>

Remote control interfaces	LAN (10/100BaseT), RS-232, GP-IB.
Peripheral interfaces	PS/2 keyboard; PS/2 mouse 2 x USB (for printer).
Remote graphical user interface	A Java™ application connected remotely via LAN or modem. Compatible with PC-based Windows® operating systems.
Firmware upgrades	Downloaded to the test set from a PC via LAN or RS-232 interface.
AC power	<p>Voltage range: 90 to 260 Vac nominal (auto-ranging).</p> <p>Frequency range: 47 to 63 Hz.</p> <p>Power: 250 VA.</p>
Environmental	<p>Operating temperature: Option 004: 15 to 40 °C (59 to 104 °F)</p> <p>Storage temperature: -20 to 70 °C (-4 to 158 °F).</p> <p>Humidity: 15% to 90% relative humidity at 40 °C (104 °F).</p> <p>Note: Instrument specifications are only valid under non-condensing conditions</p>
Dimensions (height x width x depth)	Maximum dimensions including handle: 300 mm x 365 mm x 450 mm (11.75" x 14.5" x 17.75").
Weight	23 kg (50.6 lbs) (covers all rates to 10.71 Gb/s).
Warranty	1-year as standard. Extended warranty period to 3-years available. Extended warranty period to 5-years available.
Recommended calibration cycle	2 years

Regulatory standards

EMC	<p>Complies with:</p> <ul style="list-style-type: none"> EMC Directive 89/336/EEC. Australian EMC Framework Act 1992. ICES/NMB-001. <p>Meets:</p> <ul style="list-style-type: none"> EN 55011:1991 Group 1, Class A. EN 50082-1:1992.
Electrical safety	<p>Complies with:</p> <ul style="list-style-type: none"> Low Voltage Directive 73/23/EEC. <p>Meets:</p> <ul style="list-style-type: none"> EN 61010-1:1993, IEC 61010-1 (2001 - 02). CSA C22.2 No. 1010.1-92.
Laser safety	<p>Meets:</p> <ul style="list-style-type: none"> EN 60825-1:1994 Class I. IEC 60825-1 (1993) Class I. 21 CFR Chapter 1 1040-2 Class 1.

Windows® is a U.S. registered trademark of Microsoft Corporation.

Java™ is a U.S. trademark of Sun Microsystems, Inc

This page intentionally left blank.

This page intentionally left blank.

This page intentionally left blank.

Product literature

You'll find ordering details for the OmniBER OTN J7231B in the product configuration guides at www.agilent.com/comms/otn

Related products

OmniBER OTN Family

The OmniBER OTN family is the industry's most comprehensive solution for testing ITU-T G.709 optical channel and SONET/SDH devices. Equipped with all standard telecom rates from 1.5 Mb/s to 10 Gb/s, 2.66 Gb/s (OTU-1), and 10.71 Gb/s (OTU-2) optical channel, the OmniBER OTN keeps you at the cutting-edge of next generation transport applications. For more information refer to publication no. 5988-6646EN, or www.agilent.com/comms/otn

OmniBER XM Network Simulator

The Agilent OmniBER XM network simulator offers fast and thorough system verification test (SVT) to accelerate the time to market of next-generation SONET/SDH network equipment. With multi-channel, multi-port, multi-rate and multi-user capability, the OmniBER XM can generate (in terminate or intrusive-thru mode) realistic network signals using mixed payloads, with errors and alarms, on up to 192 STS-1/AU-3 channels or up to 1344 VT1.5/TU-11 channels simultaneously. This replicates real network conditions to truly stress-test network elements, and increases the effectiveness of verification test. The OmniBER XM also simultaneously measures each channel for errors, alarms, APS switching durations, and correct connectivity, reducing test times and uncovering all performance issues. For more information, refer to www.agilent.com/find/omniberxm

RouterTester 900

The RouterTester 900 E7880A Traffic Generation and Analysis application excels for testing layer 2 and 3 devices that are used in enterprise, metro/edge and core networks. Combined with the new 10/100 Ethernet and GbE PacketTest Cards, this flexible "packet blaster" offers a cost-effective solution for performing Ethernet traffic testing on switches, routers, next generation SONET/SDH Multi-Service Provisioning Platforms and many other devices. For more information refer to publication no 5988-9860EN.

United States:

Agilent Technologies
Test and Measurement Call Center
P.O. Box 4026
Englewood, CO 80155-4026
1-800-452-4844

Canada:

Agilent Technologies Canada Inc.
5150 Spectrum Way
Mississauga, Ontario
L4W 5G1
1-877-894-4414

Europe:

Agilent Technologies
European Marketing Organisation
P.O. Box 999
1180 AZ Amstelveen
The Netherlands
(31 20) 547-2323

United Kingdom
07004 666666

Japan:

Agilent Technologies Japan Ltd.
Measurement Assistance Center
9-1, Takakura-Cho, Hachioji-Shi,
Tokyo 192-8510, Japan
Tel: (81) 426-56-7832
Fax: (81) 426-56-7840

Latin America:

Agilent Technologies
Latin American Region Headquarters
5200 Blue Lagoon Drive, Suite #950
Miami, Florida 33126
U.S.A.
Tel: (305) 269-7500
Fax: (305) 267-4286

Asia Pacific:

Agilent Technologies
19/F, Cityplaza One, 1111 King's Road,
Taikoo Shing, Hong Kong, SAR
Tel: (852) 3197-7777
Fax: (852) 2506-9233

Australia/New Zealand:

Agilent Technologies Australia Pty Ltd
347 Burwood Highway
Forest Hill, Victoria 3131
Tel: 1-800-629-485 (Australia)
Fax: (61-3) 9272-0749
Tel: 0-800-738-378 (New Zealand)
Fax: (64-4) 802-6881

www.agilent.com/comms/omniber

