

Agilent E1460A 64-Channel Relay Multiplexer

Data Sheet

- 1-Slot, C-size, register based
- Armature latching relay channels
- Configuration for testing insulation
- Includes QUIC easy-to-use terminal block
- Numerous multiplexer topologies
- Configurable for scanning voltmeter applications

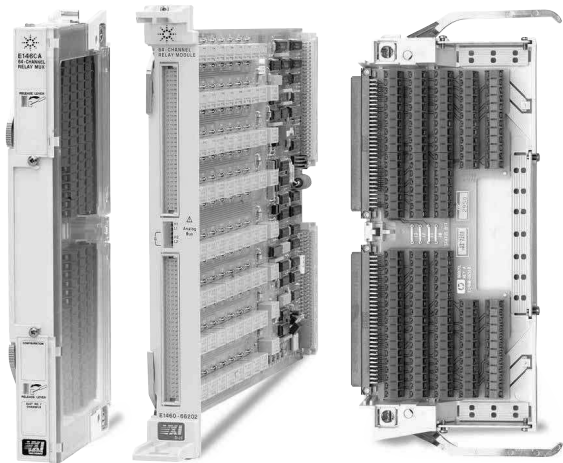

Description

The Agilent E1460A High-Density Relay Multiplexer is a **C-size, 1-slot, register-based VXI module**. This 64-channel multiplexer, using latching armature switches, offers a highly configurable, high point-count switching topology. Switching topologies include 64 two-wire, 32 three-wire, 32 four-wire, or 128 single-ended latching relay channels. This multiplexer consists of a component card with switches (labeled E1460-66202) and the QUIC screw terminal block (E1460-80011) that plugs onto the component card.

Use of SCPI commands or status bit jumpers on the terminal card configures the E1460A “wire mode” as either a 128x1-wire, 64x2-wire, 32x3-wire, or 32x4-wire multiplexer.

Applications for the E1460A include wire harness and cable testing, semiconductor testing, and printed circuit board testing.

Refer to the Agilent Technologies Website for instrument driver availability and downloading instructions, as well as for recent product updates, if applicable.

Configuration

The switch consists of eight banks of eight Hi and Lo switches, each bank having its own eight Hi and Lo common. There are seven programmable control switches and six sets of wire jumpers. These wire jumpers allow all bank commons to produce either eight 1x8 two-wire multiplexers, four 1x8 two-wire multiplexers, and two 1x16 two-wire multiplexers, or four 1x16 two-wire multiplexers. Other switching topologies are also possible.

One 2.5-in analog bus cable (E1400-61605) is included to connect the analog buses of multiple slot-adjacent E1460A modules or a slot-adjacent E1411B multimeter module. The analog bus cable, easily installed at the faceplate of the component card, lets you connect the E1460A with the E1411B DMM. Using SCPI commands sent to the E1411B, you can close channels configured as two-wire, three-wire, or four-wire in the E1460A. It is possible (but less convenient) to connect the analog bus by attaching your own wiring to the E1460A and E1411B screw terminals.

The E1460A User Manual contains configuration and programming examples for one-wire through four-wire switching modes, cable test, switchbox, scanning, triggering, and scanning with an external multimeter.

Product Specifications

Input

DC:

Maximum voltage (any terminal to any other terminal or chassis): 220 Vdc

AC rms:

Maximum voltage (any terminal to any other terminal or chassis): 250 V rms

Maximum current (per channel common, non-inductive): 1 Adc/ac rms (< 30 Vdc), 0.3 Adc/ac rms (<133 Vdc)

Maximum power per channel: 40 VA

DC

Maximum thermal offset per channel, differential

Hi-Lo: 7 μ V

Closed channel resistance: <1.5 Ω initial, <3.5 Ω end of life

Insulation resistance (between any two points): 5x10E6 Ω (40 $^{\circ}$ C, 95% RH), 5x10E8 Ω (25 $^{\circ}$ C, 40% RH)

Insulation resistance (Hi to Lo, power off): n/a

AC

Minimum bandwidth (-3 dB, 50 Ω source/load): 10 MHz (2-wire), 3 MHz (1-wire)

Crosstalk (channel-to-channel):

100 kHz: \leq 60 dB (1-wire), \leq 90 dB (2-wire)

10 MHz: n/a

Both: n/a

Closed channel capacitance: <650 pF Hi-Lo, <700 pF Lo-Chassis (both in 2-wire mode)

General Characteristics

Relays: Latching armature
Break-before-make

Power down state: Relays open on power down

Power up state: Relays open on power up

Minimum relay life:

- No load:** 5x10E6 operations
- Rated load:** 10E5 operations

Screw terminal wire size: 16 to 26 AWG (1.5, 1.2, 0.9, 0.75, 0.5 mm)

Scanning rate: 75 channels/s typ.

General Specifications

VXI Characteristics

VXI device type: Register based, A16, slave only

Size: C

Slots: 1

Connectors: P1, P2

Shared memory: None

VXI busses: None

C-size compatibility: n/a

Instrument Drivers

See the Agilent Technologies Website (http://www.agilent.com/find/inst_drivers) for driver availability and downloading.

Command module firmware:	Downloadable
Command module firmware rev:	A.02
I-SCPI Win 3.1:	Yes
I-SCPI Series 700:	Yes
C-SCPI LynxOS:	Yes
C-SCPI Series 700:	Yes
Panel Drivers:	Yes
VXIplug&play Win Framework:	Yes
VXIplug&play Win 95/NT Framework:	Yes
VXIplug&play HP-UX Framework:	No

Module Current

	I_{PM}	I_{DM}
+5 V:	0.1	0.1
+12 V:	0	0
-12 V:	0	0
+24 V:	0	0
-24 V:	0	0
-5.2 V:	0	0
-2 V:	0	0

Cooling/Slot

Watts/slot:	5.00
ΔP mm H₂O:	0.08
Air Flow liter/s:	0.42

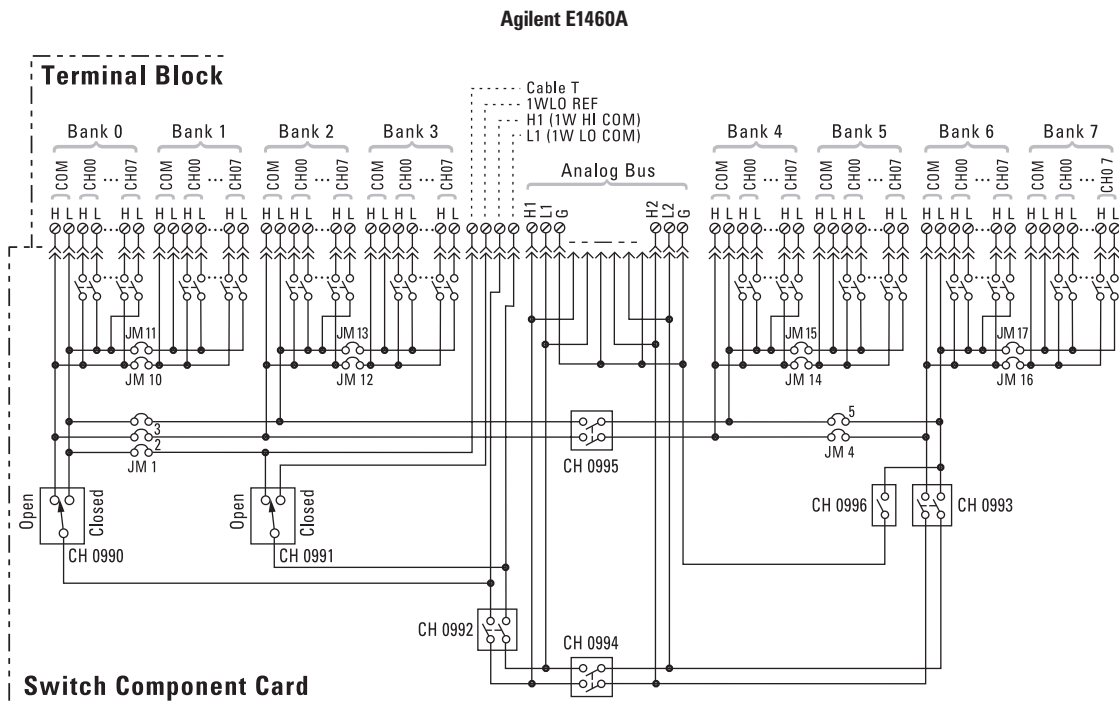

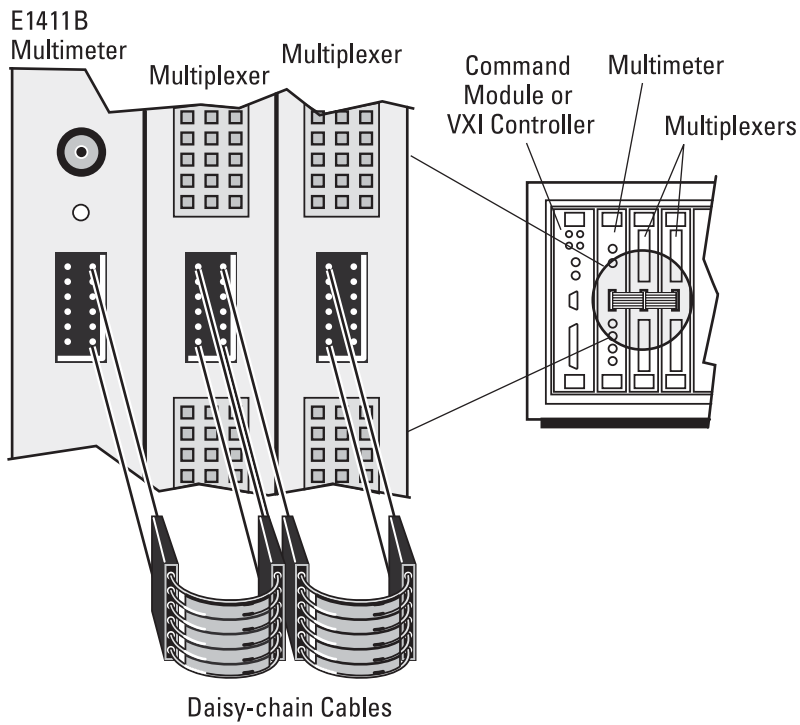

Agilent E1460A with MUX-to-MUX and MUX-to-multimeter analog bus cabling

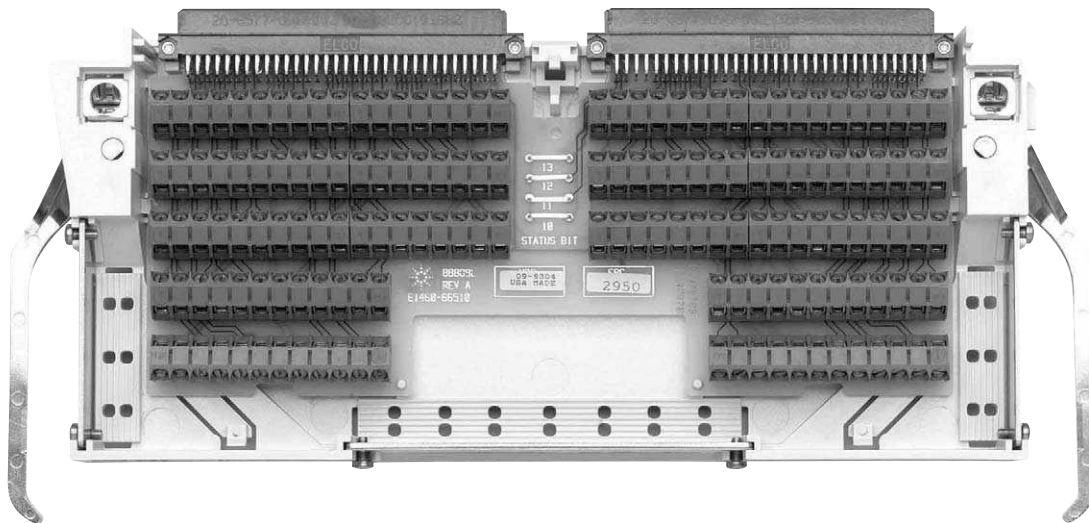

Agilent E1460A Terminal Block

Ordering Information

Description	Product No.
64-Channel Relay Multiplexer	E1460A
Pre-QUIC-type Terminal Block	E1460A 106
Crimp-and-Insert Terminal Block*	E1460A A3E*
Service Manual	E1460A 0B3
Extra Screw Terminal Block	E1460-80011
Extra Crimp-and-Insert Terminal Block (if ordered separately)*	E1460-80012*

* Note: Crimp-and-Insert Contacts are not included. See the Interconnect and Wiring section for information on ordering Crimp-and-Insert Contacts.

Agilent Technologies' Test and Measurement Support, Services, and Assistance

Agilent Technologies aims to maximize the value you receive, while minimizing your risk and problems. We strive to ensure that you get the test and measurement capabilities you paid for and obtain the support you need. Our extensive support resources and services can help you choose the right Agilent products for your applications and apply them successfully. Every instrument and system we sell has a global warranty. Two concepts underlie Agilent's overall support policy: "Our Promise" and "Your Advantage."

Our Promise

Our Promise means your Agilent test and measurement equipment will meet its advertised performance and functionality. When you are choosing new equipment, we will help you with product information, including realistic performance specifications and practical recommendations from experienced test engineers. When you receive your new Agilent equipment, we can help verify that it works properly, and help with initial product operation.

Your Advantage

Your Advantage means that Agilent offers a wide range of additional expert test and measurement services, which you can purchase according to your unique technical and business needs. Solve problems efficiently and gain a competitive edge by contracting with us for calibration, extra-cost upgrades, out-of-warranty repairs, and onsite education and training, as well as design, system integration, project management, and other professional engineering services. Experienced Agilent engineers and technicians worldwide can help you maximize your productivity, optimize the return on investment of your Agilent instruments and systems, and obtain dependable measurement accuracy for the life of those products.



Agilent Email Updates

www.agilent.com/find/emailupdates

Get the latest information on the products and applications you select.

Agilent T&M Software and Connectivity

Agilent's Test and Measurement software and connectivity products, solutions and developer network allows you to take time out of connecting your instruments to your computer with tools based on PC standards, so you can focus on your tasks, not on your connections.

Visit www.agilent.com/find/connectivity for more information.

For more assistance with all your test and measurement needs or to find your local Agilent office go to www.agilent.com/find/assist

Product specifications and descriptions in this document subject to change without notice.

© Agilent Technologies, Inc. 2005
Printed in the USA May 1, 2005
5965-5606E



Agilent Technologies