

## Agilent L4452A Multifunction with Digital I/O, D/A, Totalizer

Data Sheet

- LXI compliance includes built-in Ethernet connectivity
- Fully-featured graphical Web interface
- 32-bits of digital I/O up to 42 V
- 100 kHz gated totalizer
- Two  $\pm 12$  V analog outputs with 1 mV of resolution
- Software drivers for most common programming environments



**Multifunction instrument offers your system control functionality wherever your application needs it**

The Agilent L4452A is a multifunction instrument that is LXI Class C compliant. With its small size and Ethernet connectivity, this multifunction instrument can be placed wherever your application needs it.

The Agilent L4452A allows great flexibility for a variety of sense and control applications.

It combines four 8-bit channels of digital input and output, a 100 kHz gated totalizer, and two  $\pm 12$  V analog outputs all on a single earth-referenced module.

Using this LXI instrument, you'll get all the benefits of an Ethernet connection, instrument Web server, standard software drivers and more. The LXI standard is supported by multiple vendors, enabling lower cost of test with accelerated test integration and development.



**Agilent Technologies**

**Digital I/O, D/A converter and totalizer for your most common test requirements**

The L4452A combines digital I/O, analog outputs and a gated totalizer for your most common system control needs.

The digital I/O supports output levels up to 42 V. These channels can be used with an external power supply to control external devices or to sense limit switch and digital bus status with no complex handshake modes.

You can use the totalizer input to count events. The digital inputs and totalizer inputs may be included in a scan. Alarm limits for the digital and event counter inputs are evaluated continuously, capturing and logging alarm conditions even between scans.

The analog outputs can output up to  $\pm 12$  V or 10 mA DC with 1 mV of resolution. They can be used to source bias voltages to your device under test, to control your analog programmable power supplies, or use the outputs as set points for your control systems.

External trigger capabilities make it easy for you to time and synchronize measurements and other events. This can help you determine when to begin or end a scan.

**System connections you can trust**

The L4452A comes with one heavy duty 50-pin Dsub connector that allows for simple, reliable connection options. Each connector uses 30 micro-inches of gold to ensure a repeatable, accurate measurement. Flexible connection options include:

- Detachable terminal blocks with strain relief
- Low-cost, standard 50-pin Dsub connector kits and cables
- Mass interconnect solutions

**Ethernet connectivity enables simple connection to the network and remote access to measurements**

The Ethernet interface offers high-speed connections that allow for remote access and control. You can set up a private network to filter out unwanted LAN traffic and speed up the I/O throughput, or take advantage of the remote capabilities and distribute your tests worldwide. Monitor, troubleshoot, or debug your application remotely. Ethernet communication also can be used with the support of LAN sockets connections.

The optional GPIB interface has many years of proven reliability and can be used for easy integration into existing applications.

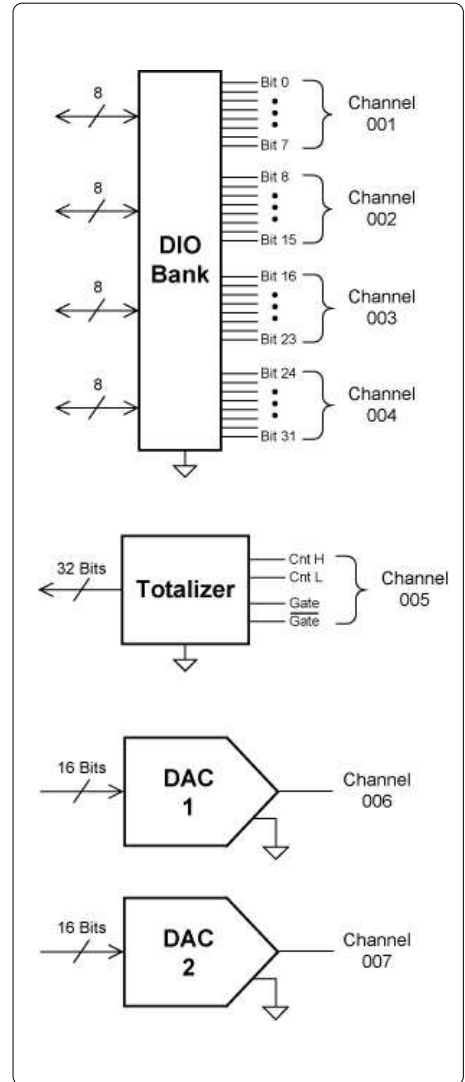

**Figure 1.** L4452A Multifunction Digital I/O, D/A, totalizer

The L4452A ships with the Agilent E2094N I/O Libraries Suite making it easy for you to configure and integrate instruments into your system – even if your system includes instruments from multiple vendors.

**Fully-featured graphical Web interface makes it easy to set-up and troubleshoot your tests from anywhere in the world**

The built-in Web browser interface provides remote access and control of the instrument via a Java-enabled browser such as Internet Explorer. Using the Web interface, you can set up, troubleshoot, and maintain your instrument from remote locations.

- View and modify instrument setup
- Configure I/O channels, analog outputs, totalizer and alarms
- Read and write I/O channels
- Output analog channels
- View error queue
- Get status reports, current configuration, firmware revisions, and more

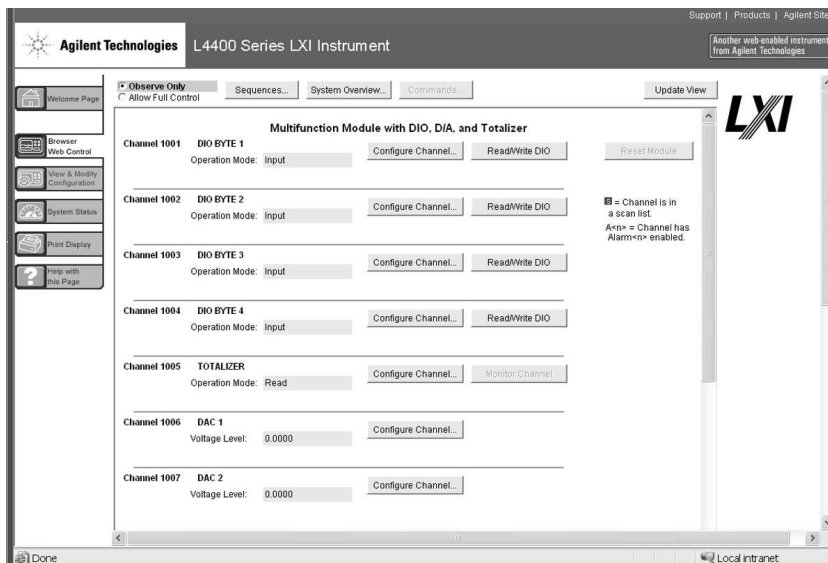

**Figure 2.** The Web interface makes it easy to set up, troubleshoot and maintain your test remotely

Additionally, since the Web server is built into the instrument, you can access it on any operating system that supports the Web browser without having to install any special software. Password protection and LAN lockout are also provided to limit access for additional security.

**Software for most popular programming environments**

Full support for standard programming environments ensures compatibility and efficiency. You can use direct I/O with the software you

already have and know, or use standard IVI and LabVIEW™ software drivers that provide compatibility with the most popular development environments:

- Agilent T&M Toolkit for Microsoft Visual Studio®.NET and Agilent VEE Pro
- National Instruments LabVIEW, LabWindows/CVI, TestStand, and Switch Manager
- Microsoft C/C++® and Visual Basic®

**Multifunction instrument wherever your application needs it**



Power button

Status LEDs

Easy connection options with terminal blocks, standard 50-pin cables or connector kits

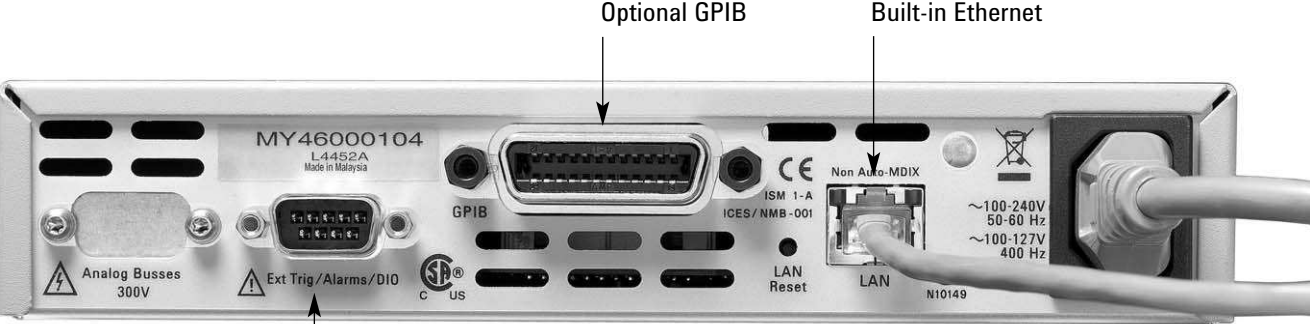

Optional GPIB

Built-in Ethernet

External trigger to synchronize events

## Product Specifications

### Specifications and Characteristics

#### Digital input/output characteristics

Four 8-bits channels, 8 bits wide, input or output, non-isolated

Vin(L)	< 0.8 V (TTL)
Vin(H)	> 2.0 V (TTL)
Vout(L)	< 0.8 V @ Iout = -400 mA
Vout(H)	> 2.4 V @ Iout = 1 mA
Vin(H) max	< 42 V with external open drain pull-up
Alarm	Maskable pattern match or state change
Speed	4 ms (max) alarm sampling Latency
Read/write speed	95/s

#### Totalize input characteristics

Max count	$2^{28} - 1$
Totalize input	100 kHz (max) rising or falling edge, programmable
Signal level	1 Vp-p (min) 42 Vpk (max)
Threshold	0 V or TTL
Gate input	TTL-Hi, TTL-Lo, or none
Count reset	Manual or read + reset
Read speed	85 rdgs/s

#### Analog output characteristics

DAC 1, 2	$\pm 12$ V, non-isolated
Resolution	1 mV
IOUT	10 mA max
Settling time	1 ms to 0.01% of output
Accuracy	$\pm$ (% of output + mV) 1 year (0.25% + 20 mV)
Temp. coefficient	$\pm$ (0.015% + 1 mV)/°C

## Product Specifications (continued)

### Data out of memory to LAN or GPIB

(data transfer rate with 1000 channel blocks)

	<b>GPIB</b>	<b>LAN (w/ VXI 11)</b>
	<b>rds/s</b>	<b>rds/s</b>
Readings	2560	3542
readings with timestamp	1304	1826
readings with all format options ON	980	1361

### Scan triggering

Source	Interval, external, software, or on monitor channel alarm
Scan count	1 to 50,000 or continuous
Scan interval	0 to 99 hours; 1 ms step size
Channel delay	0 to 60 seconds per channel; 1 ms step size
External trig delay	<2 ms. With monitor on <200 ms
External trig jitter	<2 ms

### Alarms

Digital inputs	Digital in maskable pattern match or state change Totalize: Hi limit only
Alarm on channel	Alarm evaluated each reading
Alarm outputs	2 TTL compatible, Selectable TTL logic Hi or Lo on fail
Latency	5 ms (typical)

### Memory

Type	Volatile
Readings	500,000 with timestamp Readable during scan
States	5 instrument states with user label in non-volatile memory

### General specifications

Power supply	Universal 100 V to 240 V $\pm 10\%$
Power line frequency	50 Hz to 60 Hz $\pm 10\%$ automatically sensed
Power consumption	15 VA
Operating Environment	Full accuracy for 0°C to 55°C Full accuracy to 80% R.H. at 40 °C Pollution degree 1 of IEC 61010-1
Storage environment	-40°C to 70°C
Dimensions (H x W x L)	40.9 x 212.3 x 379.3 mm 1.61 x 8.36 x 14.93 in
Weight	3.6 kg, 8 lbs
Safety conforms to	CSA, UL/IEC/EN 61010-1
EMC conforms to	IEC/EN 61326-1, CISPR 11
Warranty	1 year

## Product Specifications (continued)

### Software

Agilent connectivity software included	Agilent I/O Libraries Suite 14 or greater (E2094N)
--	--

### Minimum system requirements

PC hardware	Intel Pentium 100 MHz, 64 Mbyte RAM, 210 Mbyte disk space Display 800x600, 256 colors, CD-ROM drive
Operating system <sup>1</sup>	Windows <sup>®</sup> 98 SE/NT/2000/XP

### Computer interfaces

Standard LAN 10BaseT/100BaseTx
Optional IEEE 488.2 GPIB

### Software driver support for programming languages

Software drivers	IVI-C and IVI-COM for Windows NT <sup>®</sup> /2000/XP LabVIEW
------------------	---

### Compatible with programming tools and environments

Agilent	VEE Pro
	T&M Toolkit (reqs Visual Studio.NET)
National Instruments	TestStand
	Measurement Studio
	LabWindows/CVI
	LabVIEW
Microsoft	Switch Executive
	Visual Studio.NET <sup>®</sup>
	C/C++
	Visual Basic 6 <sup>®</sup>

<sup>1</sup> Load I/O Libraries Version M for Windows NT support or version 14.0 for Windows 98 SE support

## Ordering information

### **L4452A Multifunction instrument with digital I/O, D/A converters and totalizer**

Includes User's guide on CD, power cord, and Quick Start package

#### **Option - GPIB**

Adds GPIB interface

#### **Option 0B0**

Deletes printed manual set, full documentation included on CD ROM

#### **Option ABA**

English printed manual set

## Connection Options

Select terminal block for discrete wiring, cables or connector kits. Cables and connector kits require one per instrument.

### **34952T**

Terminal block for 34952A and L4452A Multifunction

### **Y1135A**

1.5 m 50-pin Dsub, M/F twisted pair with outer shield cable – 300 V

### **Y1136A**

3 m 50-pin Dsub, M/F twisted pair with outer shield cable – 300 V

### **Y1141A**

Solder cup connector kit with male 50-pin Dsub

## Other accessories

### **Y1160A**

Rack mount kit for L4400 series instruments-racks 2 instruments side-by-side with slide tray

For additional information please visit:

<http://www.agilent.com/find/L4452A>

## Related Agilent literature

### Data Sheets

5988-6302EN

Agilent VEE Pro

5989-1441EN

Agilent W1140A-TKT

T&M Toolkit 2.0 with Test Automation

5989-1439EN

Agilent E2094N

I/O Libraries Suite 14

### **Agilent Technologies' Test and Measurement Support, Services, and Assistance**

Agilent Technologies aims to maximize the value you receive, while minimizing your risk and problems. We strive to ensure that you get the test and measurement capabilities you paid for and obtain the support you need. Our extensive support resources and services can help you choose the right Agilent products for your applications and apply them successfully. Every instrument and system we sell has a global warranty. Two concepts underlie Agilent's overall support policy: "Our Promise" and "Your Advantage."

#### **Our Promise**

Our Promise means your Agilent test and measurement equipment will meet its advertised performance and functionality. When you are choosing new equipment, we will help you with product information, including realistic performance specifications and practical recommendations from experienced test engineers. When you receive your new Agilent equipment, we can help verify that it works properly and help with initial product operation.

#### **Your Advantage**

Your Advantage means that Agilent offers a wide range of additional expert test and measurement services, which you can purchase according to your unique technical and business needs. Solve problems efficiently and gain a competitive edge by contracting with us for calibration, extra-cost upgrades, out-of-warranty repairs, and on-site education and training, as well as design, system integration, project management, and other professional engineering services. Experienced Agilent engineers and technicians worldwide can help you maximize your productivity, optimize the return on investment of your Agilent instruments and systems, and obtain dependable measurement accuracy for the life of those products.



#### **Agilent Email Updates**

[www.agilent.com/find/emailupdates](http://www.agilent.com/find/emailupdates)

Get the latest information on the products and applications you select.



#### **Agilent Direct**

[www.agilent.com/find/agilentdirect](http://www.agilent.com/find/agilentdirect)

Quickly choose and use your test equipment solutions with confidence.



#### **Agilent Open**

[www.agilent.com/find/open](http://www.agilent.com/find/open)

Agilent Open simplifies the process of connecting and programming test systems to help engineers design, validate and manufacture electronic products. Agilent offers open connectivity for a broad range of system-ready instruments, open industry software, PC-standard I/O and global support, which are combined to more easily integrate test system development.

## **www.agilent.com**

**For more information on Agilent Technologies' products, applications or services, please contact your local Agilent office. The complete list is available at:**

[www.agilent.com/find/contactus](http://www.agilent.com/find/contactus)

### **Phone or Fax**

#### **United States:**

(tel) 800 829 4444  
(fax) 800 829 4433

#### **Canada:**

(tel) 877 894 4414  
(fax) 800 746 4866

#### **China:**

(tel) 800 810 0189  
(fax) 800 820 2816

#### **Europe:**

(tel) 31 20 547 2111

#### **Japan:**

(tel) (81) 426 56 7832  
(fax) (81) 426 56 7840

#### **Korea:**

(tel) (080) 769 0800  
(fax) (080) 769 0900

#### **Latin America:**

(tel) (305) 269 7500

#### **Taiwan:**

(tel) 0800 047 866  
(fax) 0800 286 331

#### **Other Asia Pacific Countries:**

(tel) (65) 6375 8100  
(fax) (65) 6755 0042

Email: [tm\\_ap@agilent.com](mailto:tm_ap@agilent.com)

Contacts revised: 09/26/05

Product specifications and descriptions in this document subject to change without notice.

Microsoft® and Windows® are U.S. registered trademarks of Microsoft® Corporation

LabVIEW™ is a U.S. registered trademark of National Instruments Corporation

© Agilent Technologies, Inc. 2006

Printed in the USA, February 28, 2006

5989-4831EN



**Agilent Technologies**