

Agilent 4352S VCO/PLL Signal Test System

**A Customized, Multi-Functional Test System
for VCO/PLL Evaluation Up to 12.6 GHz**

Product Overview

Discontinued Product Information — For Support Reference Only —

Information herein, may refer to products/services no longer supported. We regret any inconvenience caused by obsolete information. For the latest information on Agilent's test and measurement products go to: www.agilent.com/find/products

In the US, call Agilent Technologies at 1-800-829-4444
(any weekday between 8am–5pm in any U.S. time zone)

World-wide Agilent sales office contact information is available at: www.agilent.com/find/contactus

Essential for characterization of synthesized oscillator design
and for VCO production test in high-throughput applications

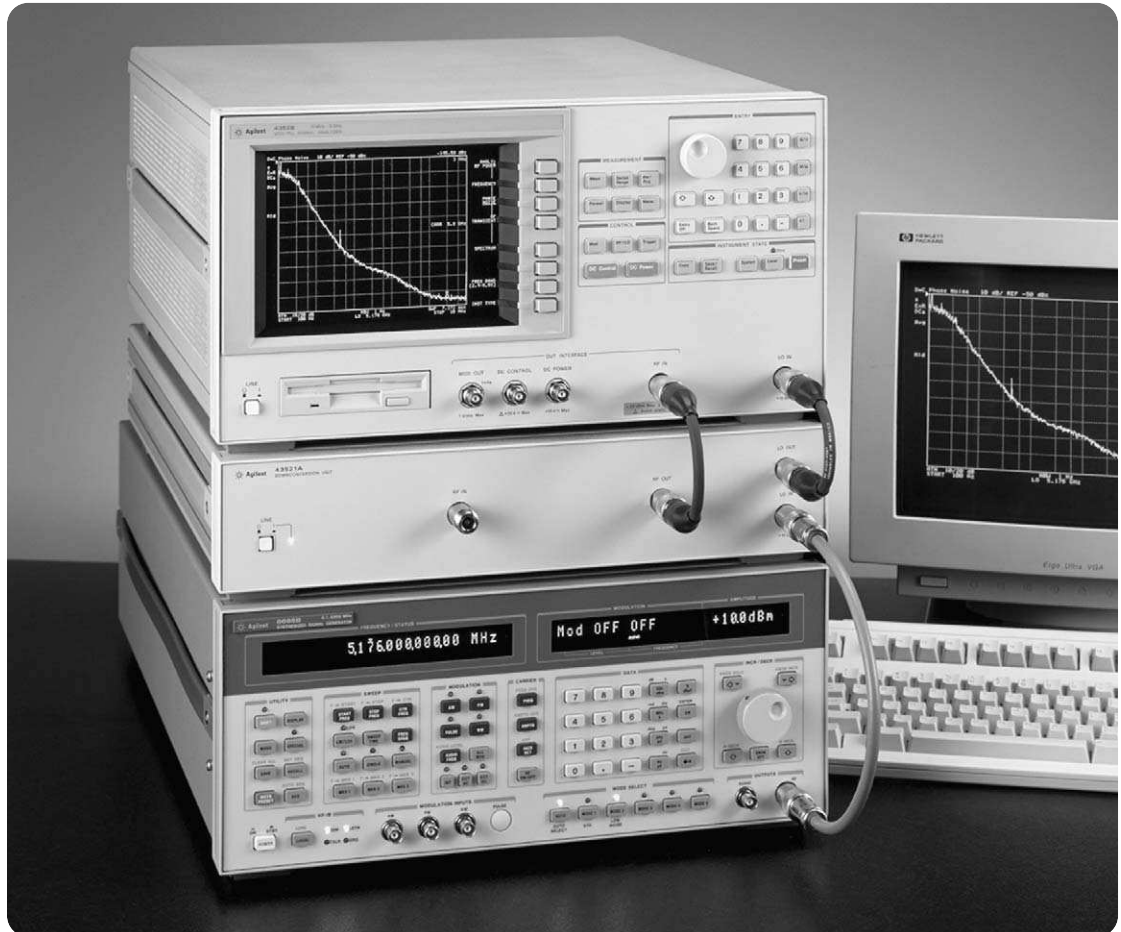

Agilent Technologies

For Oscillator Designers and Test Engineers

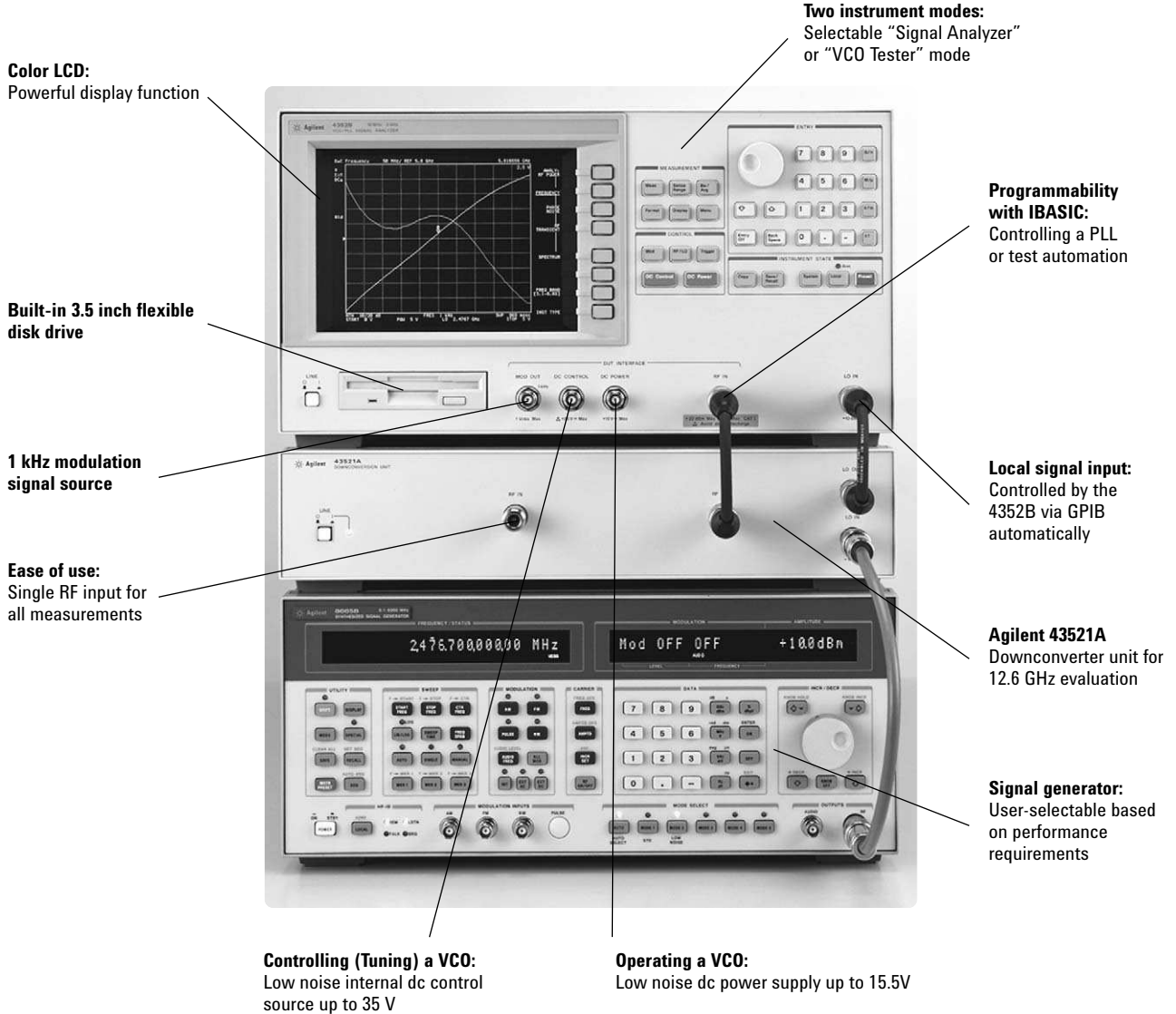

Agilent 4352S Key Specifications

Sources characteristics

- DC power voltage:**
- 0 to 15.5 V (50 mA max.)
 - 1 mV step
- DC control voltage:**
- 0 to 20 V (20 mA max.)
 - -15 to 35 V (Opt. 001)
 - 100 μ V step
- 1 kHz signal voltage:**
- 0 to 1 Vrms
 - 1 mVrms step

Measurement parameters Frequency:

- 10 MHz to 3 GHz (12.6 GHz max. with Agilent 43521A)
- 1 kHz resolution

RF power:

- -10 dBm to +20 dBm (-20 dBm to +20 dBm @ 2.4 GHz to 12.6 GHz with the 43521A)
- 0.01 dB resolution

Phase noise:

- 100 Hz to 10 MHz offset
- -90 dBc/Hz @100 Hz (typical)
- -137 dBc/Hz @10 kHz (typical)
- -157 dBc/Hz @1 MHz (typical)

Spectrum:

- 10 MHz to 3 GHz (12.6 GHz max. with the 43521A)
- 10 MHz span (max.)

RF Transient:

- 50 Hz resolution (min.) with 12.5 μ second sampling

FM deviation:

- 0 to 200 kHz

DC power current:

- 0 to 50 mA

Product Summary

Synthesized local oscillators (LOs) for frequency conversion exist everywhere that communications and wireless radios live. The synthesized oscillator (synthesizer) is essentially a PLL (Phase-Lock-Loop) that is made up of a VCO (Voltage-Controlled-Oscillator) to generate a carrier signal, a PLL-IC to control the carrier frequency, and a crystal oscillator to provide a low-noise reference signal to the PLL. The latest developments in the wireless communication systems for PCS, DECT, and others demand the absolutely best design effort for LOs to ensure quality communication. However, characterizing VCO and PLL performance of LOs is a critical and time-consuming job for design and manufacturing test engineers in those radio companies, as well as VCO suppliers. Now, the Agilent 4352S VCO/PLL Signal Test System makes it simple and easy to evaluate VCO and PLL performance, and dramatically improve the efficiency of quality oscillator design as well as VCO testing productivity.

Combine analyzing and testing capabilities with ease of use

The system has two operating modes, "Signal Analyzer" and "VCO Tester" mode. The "Signal Analyzer" mode offers the following measurement functions. In this mode, the 4352S gives you the trace curve of each parameter on the display with a single cabling hookup.

Simple and multi-functional test system

The 4352S VCO/PLL signal test system is a simple configuration and multi-functional system which provides both comprehensive analyzing capabilities for designers and high test throughput for the production line. The 3 GHz standard system consists of only two instruments, the 4352B VCO/PLL signal analyzer and a signal generator controlled via GPIB. When the 43521A downconverter unit is added to the standard system, the system can achieve the same multi-function capability up to 12.6 GHz.

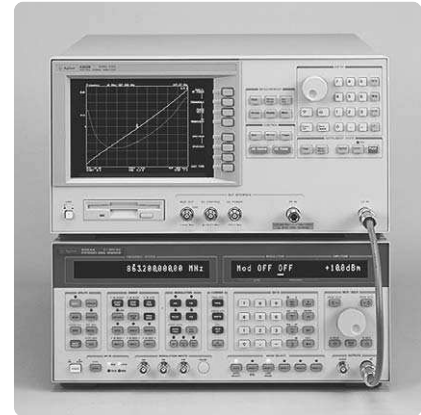

3 GHz standard system

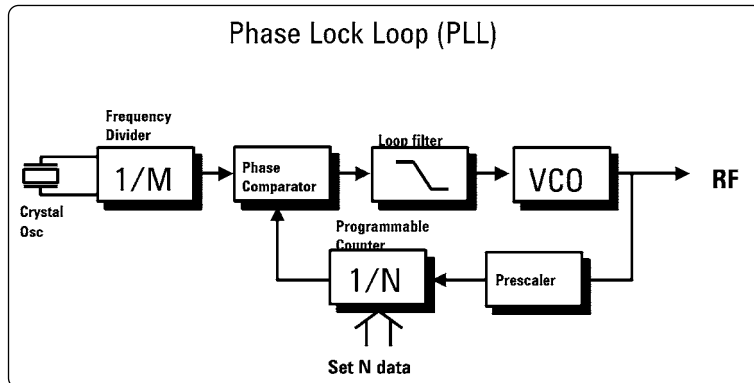

Synthesized oscillator block diagram

- RF power level vs. dc control (tuning) voltage characteristic (VCO)
- Frequency vs. dc control (tuning) voltage characteristic (VCO)
- Tuning sensitivity (VCO)
- Phase noise
- RF transient
- Spectrum
- RF power level
- Frequency
- Dc power current
- FM deviation/Residual FM
- Phase noise (Carrier-to-Noise ratio)

These powerful measurement capabilities improve your test productivity. By saving test time, more comprehensive testing is possible and reduce instrument rack space.

The "VCO Tester" mode offers the following parameters measurement capability. In this mode, a specified parameter is measured quickly with numeric annotation shown on the display.

VCO/PLL Measurements Made Easy...

Outstanding phase noise measurement capability

The 4352S system's innovative "carrier lock multi-mode PLL" technology provides accurate and high-speed phase noise measurement capability. The main function of this technology locks the system unto the carrier of the measured signal automatically. In this way it always measures phase noise with a stable offset frequency by canceling the carrier drift. The usual tedious phase noise measurement speed is improved dramatically with up to 10 times reduction in test time. By adding the Agilent microwave downconverter, users can extend the frequency coverage up to 26.5 GHz for phase noise measurement.

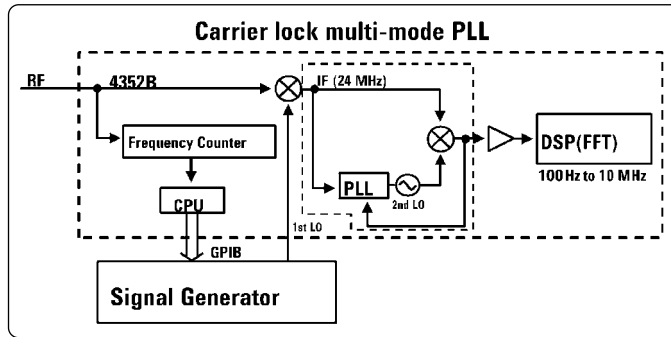

The carrier lock multi-mode PLL technology achieves accurate and high-speed phase noise measurement

Internal low noise signal sources provide accuracy and flexibility

The 4352S provides and controls the dc power supply, the dc control (tuning) voltage source and 1kHz signal source. These signal sources are floated from the ground and isolated from external noise to ensure accuracy and repeatability. In particular, the dc control voltage source which supplies the ultra-low-noise dc signal (1 nV $\sqrt{\text{Hz}}$ at 10 kHz offset) to measure free-running VCOs allows you to measure without a low pass filter (LPF). This is superior to the conventional method because it reduces noise on the control signal, yet enables the system to change the control voltage quickly while improving flexibility and total throughput.

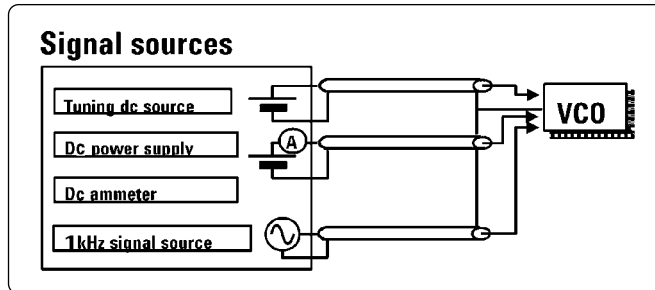

Internal signal sources allow you to measure a VCO without a low pass filter

Controlling the output frequency of free-running VCOs by your 4352S

Using the 4352S, you can control the output frequency of free-running VCOs very easily. The AFC (Automatic Frequency Control) function disciplines a free-running VCO to move to the user-specified target frequency with optimum speed. This powerful capability removes the need to manually adjust the dc control voltage for setting the VCO to a specified output frequency. The AFC function can be activated in the Tester mode and phase noise or spectrum measurement in the analyzer mode.

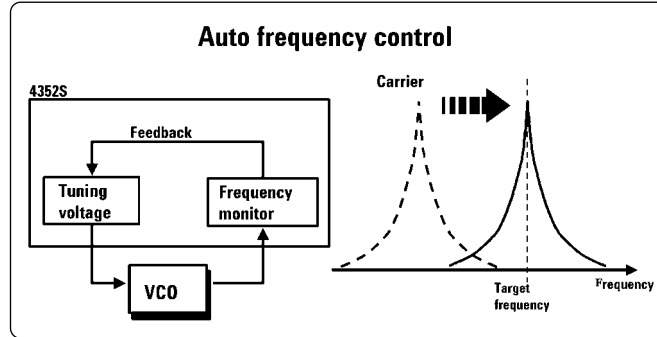

The AFC function controls the frequency of a free-running VCO

Automatic setup of PLL divider

The 4352S can automatically change the PLL divider ratio using a combination of the built-in IBASIC (instrument BASIC) programming function and the 24-bit I/O interface. This combination provides Data, Clock, and Strobe (load) signals to the PLL, so that you can easily evaluate the PLL with an IBASIC measurement program at a wide variety of carrier frequency settings.

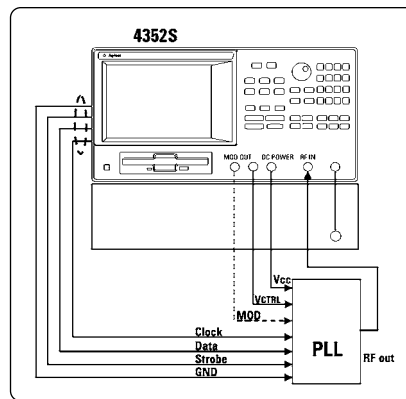

PLL measurement example

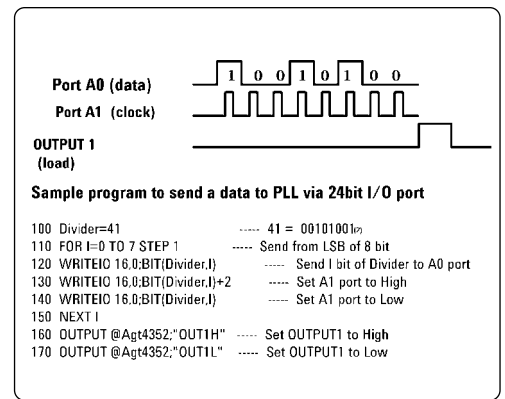

The IBASIC program controls a PLL via the 24-bit I/O interface

24-bit parallel digital I/O interface

The 24-bit parallel I/O interface can be used for controlling a PLL or sending out pass/fail test results to other automated test equipment, such as component handlers or to externally trigger the 4352S from the handler.

Easy measurement automation with IBASIC

The system's IBASIC program capability can create custom test sequences to measure VCO parameters and to synchronize the system with PLL circuits. It can also be used to create interfaces with component handlers. In addition, secondary VCO parameters such as signal-to-noise, static control voltage (tuning) sensitivity, power voltage sensitivity (frequency pushing) etc. can be obtained automatically by IBASIC programs. The IBASIC enables the 4352S to control another instruments via GPIB, also.

Saving set-up, data and program into the built-in 3.5 inch disk drive

The built-in 3.5 inch floppy disk drive lets you save and recall test setups, IBASIC test programs, and measurement results with either LIF or MS-DOS® format (720 kB or 1.44 MB). If you save your measurement results in MS-DOS format, you can analyze the statistics of your accumulated measurement results in your PC software environment.

Frequency Expansion of Standard System Up to 12.6 GHz

43521A downconverter unit

With growth in wireless technologies toward more efficient designs at higher frequencies, the 4352S including the 43521A downconverter unit expands the frequency coverage from 3 GHz to 12.6 GHz with the ability to offer the comprehensive measurement solutions for VCO/PLL design and production.



43521A downconverter unit

Same Multi-Functional capability from 10 MHz to 12.6 GHz

The 43521A downconverter unit has two signal paths. One is the direct path that is from the RF input port of the 43521A to the input port of the 4352B directly. The other is the heterodyne path which downconverts the RF input signal to the proper signal for the input of the 4352B. Either path is available so that you don't need any changes for DUT connection. Since the level loss between the RF input port from the 43521A and the RF input port of the 4352B is calibrated, the power level related measurement such as RF power measurement can be performed properly. When the heterodyne path is selected, the external signal generator (SG) is used as the local signal generator for downconversion. The frequency doubler in the 43521A doubles the local signal from the SG so that the double frequency of the SG is maximum as the local signal. Then the built-in 600 MHz oscillator in the 43521A offers the local signal of the 4352B so that you can perform the 12.6 GHz evaluation by using only one 6 GHz SG.

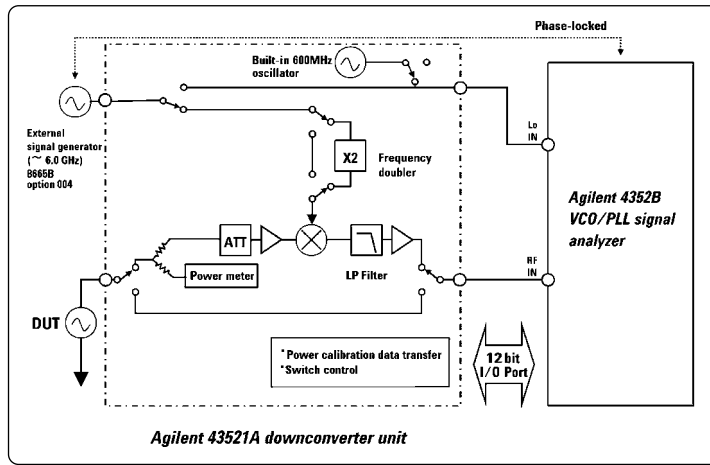

43521A block diagram

RF power measurement in 43521A

The 43521A has the built-in power meter capability that the other downconverters never achieved. The input signal is divided by the power divider, and the divided signal is measured by the built-in power meter as shown in the block diagram. The measurement result transfers to the 4352B via 12 bit I/O port, and the 4352B displays the power value. Therefore, the 4352S including the 43521A can perform all measurement parameters' evaluation which can be achieved by the standard system.

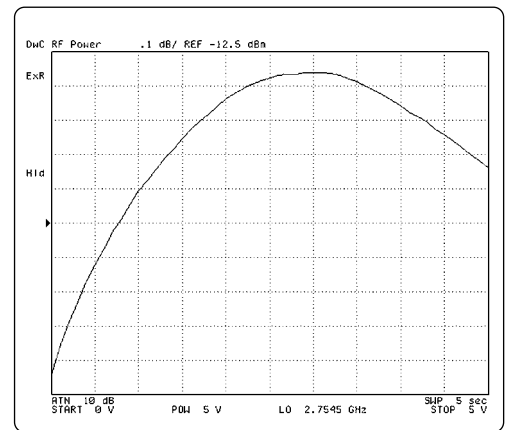

RF power measurement of 5.8 GHz VCO using 43521A

A Wide Variety of VCO/PLL Characteristic Evaluations are Available

The “Analyzer” mode simplifies the complete characterization of VCO/PLL performance and makes quality oscillator design easy. The displays present the parameters in user-required terminology.

RF power vs. dc control (tuning) voltage characteristic

You can quickly obtain the VCO carrier level vs. dc control voltage characteristic, and evaluate the characteristic influences at the same time while changing the dc power voltage easily.

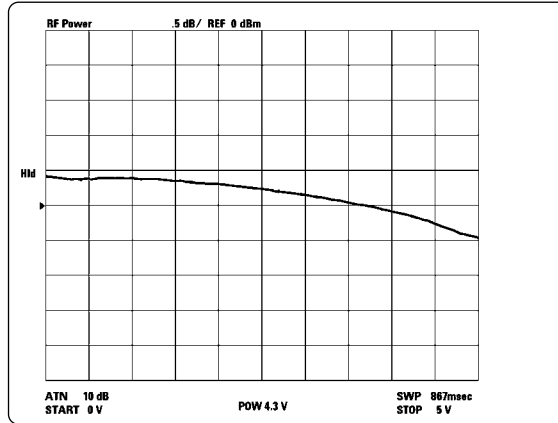

RF power measurement vs. dc control voltage

Frequency and tuning sensitivity characteristic

The frequency vs. dc control (tuning) voltage characteristic can be measured easily. In addition, the tuning sensitivity, which is the differential of the frequency vs. dc control voltage characteristic, can be simultaneously evaluated on the same display. This useful measurement capability ensures stable PLL circuit design. The aperture to be used to derive the tuning sensitivity can be flexibly set to match the characteristic of the device under test.

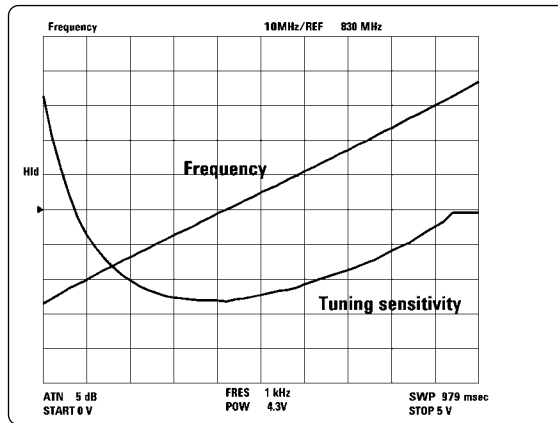

Frequency/tuning sensitivity measurement

Phase noise vs. offset frequency characteristic

Using the 4352S, your phase noise evaluation efficiency is dramatically improved. The 4352S uses a very simple measurement setup and takes only 7.4 seconds to measure the phase noise characteristic at 801 measurement points per one sweep within the offset range of 100 Hz to 10 MHz. Basically, it can be performed automatically by setting only offset frequency range thanks to “carrier lock multi-mode PLL”.

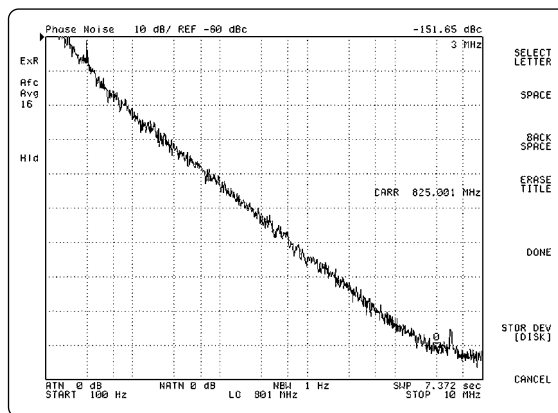

The 4352S offers simple and quick phase noise measurement with an “offset tracking” technique

Spectrum monitoring

The 4352S can make a spectrum measurement with up to 10 MHz span. This allows you to easily detect unfavorable signals such as harmonics and spurious products in a VCO or PLL. The CARRIER MENU of this function can search the fundamental, 2nd harmonics or 3rd harmonics of the measured signal and set it to center of the span automatically.

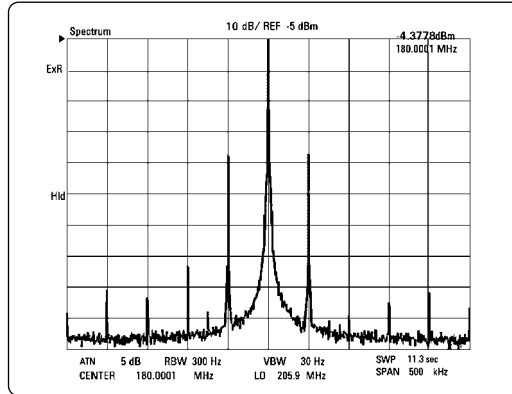

PLL spurious can be evaluated by spectrum measurement function

Frequency transient characteristics

The frequency transient measurement function evaluates the frequency vs. time characteristic such as PLL frequency lock up time and VCO post tuning drift with high resolution up to 50 Hz and 12.5 μ second sampling. In addition, the 4352S can provide the strobe (load enable) signal via the 24-bit I/O interface to synchronize the PLL setup change with the measurement trigger.

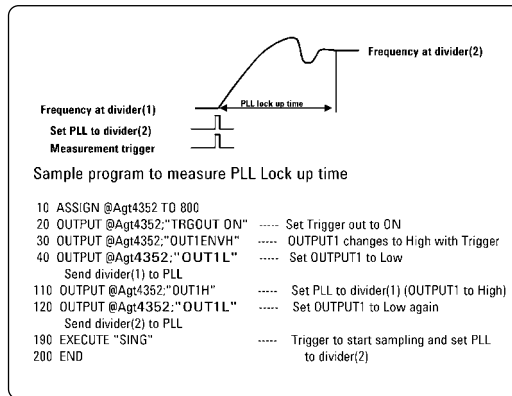

The measurement trigger can synchronize with the PLL setup change

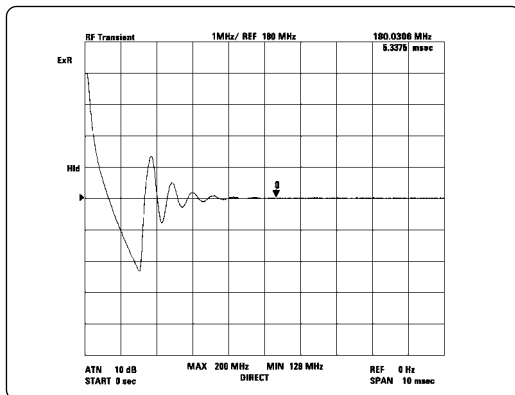

Measure wide frequency transition using DIRECT mode

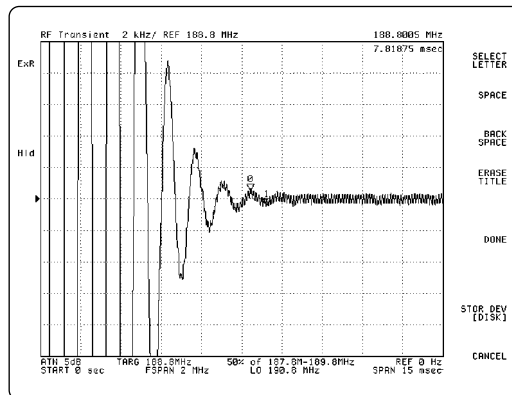

The final part of frequency transition can be measured with up to 50 Hz resolution and 12.5 micro second sampling

Analyze Measurement Data Easily

Integrated noise function

In phase noise evaluation, the latest firmware can make not only the log sweep but also linear sweep. When the integrated noise function is used in the linear sweep, the noise between two points you specified by markers can be automatically integrated, and displayed. This function contributes to the efficient noise evaluation such as the ACP in communication equipment.

Four traces on the color display

The 4352S has up to four data traces so you can easily compare the characteristic of your device under different conditions on the same display. This function dramatically improves your oscillator evaluation efficiency. And, it can be used in conjunction with other 4352S features such as high speed phase noise measurement. For example, the phase noise comparison of the VCO and PLL is available to verify the PLL loop bandwidth. Moreover, the PLL phase noise characteristics at a specific carrier frequency can be quickly compared with those at lower and higher frequencies on the display.

Marker analysis function

Up to five markers can be used on one trace for verifying data on the trace or for searching peak/maximum/minimum/target values under detailed analysis.

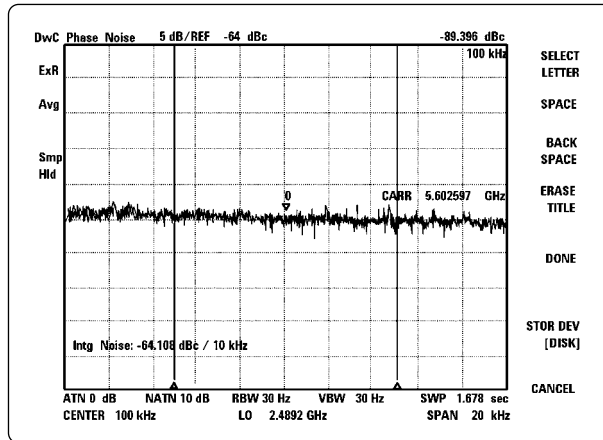

Powerful integrated noise function

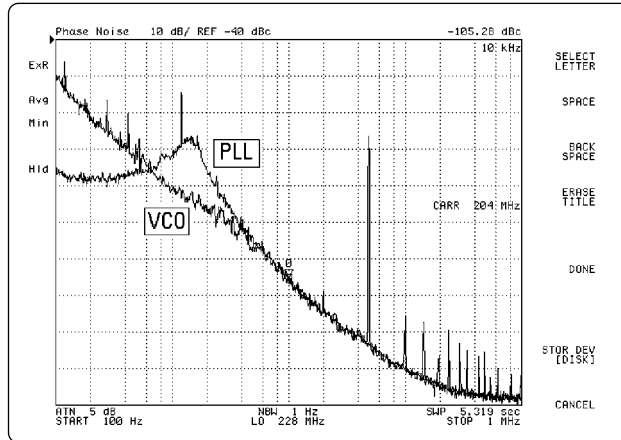

The characteristics under different conditions are compared on the same display

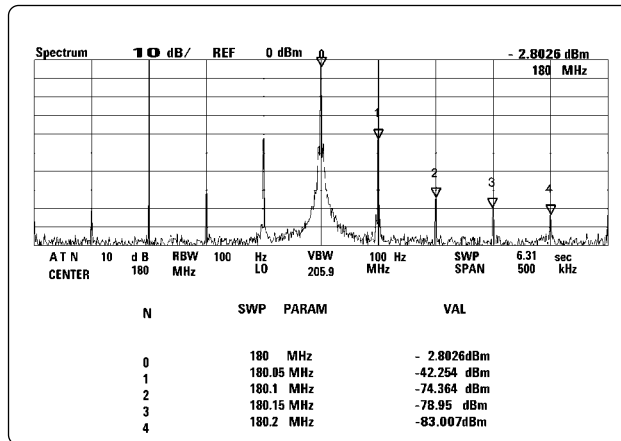

Marker analysis function shows measured data at multiple frequencies

Limit line function

To design for the optimized characteristics of the device, circuit adjustments are often required. The 4352S's limit line function enables you to adjust your device efficiently while observing the adjustment effects on the screen. In addition, Go/No-Go testing on your production line can be performed on the display using this function. The "VCO Tester" mode reduces test setup time, simplifies test sequences and delivers high test throughput on a VCO production line. The IBASIC programming is useful for creating test sequences and the 24-bit parallel I/O interface allows users to interface directly to automatic component handlers, so you no longer have to build a conventional rack-and-stack test system.

The "VCO Tester" mode offers the following parameters measurement capability.

RF power

Frequency

Dc power current (shown in figure)

FM deviation(residual FM)

Phase noise (C/N ratio)

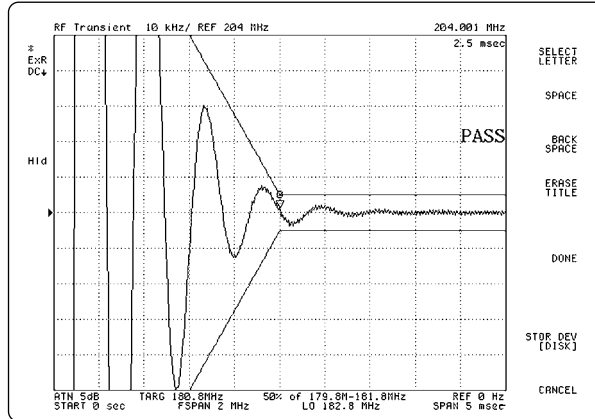

Go/No-Go testing can be performed with limit line function

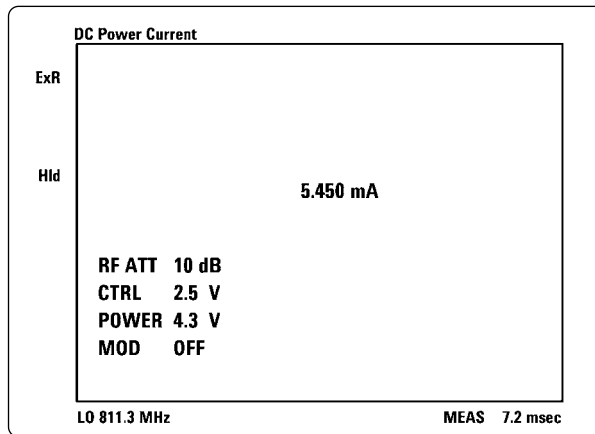

Dc power current

MEASTIME	2.464 (sec)	Stop
DC POWER	4.300 (V)	
FM MOD AMPLITUDE	.350 (V)	Continue
DC CONTROL VOLTAGE	1.000 (V)	
FREQUENCY	813.513 (MHz)	Run
DC CONTROL VOLTAGE	4.000 (V)	
FREQUENCY	852.967 (MHz)	Pause
SENSITIVITY	13.15 (MHz/V)	
FREQUENCY @ -.25 (V)	-149 (kHz)	
FREQUENCY @ .25 (V)	141 (kHz)	
CENTER FREQUENCY	830.000 (MHz)	Stop
CTRL V for CENT FREQ	2.244 (V)	
RF POWER	.35 (dBm)	
DC CURRENT	5.74 (mA)	Edit
FM DEVIATION	9.930 (kHzpeak)	
C/N at 25 kHz OFS		
1 Hz NBW	112.1 (dBc)	COMMAND
S/N RATIO	46.0 (dB)	ENTRY
—		ON KEY LABELS

Measurement example of IBASIC program

Agilent 4352B VCO/PLL Signal Analyzer Specification Summary

Source characteristics

Dc power supply

- Dc voltage level :**
• 0 to +15.5 V (50 mA max.)
- Dc voltage resolution:**
• 1 mV
- Dc voltage accuracy:**
• $\pm(0.2\% + 2 \text{ mV})$
- Noise density:**
• $< 10 \text{ nV}/\sqrt{\text{Hz}}$ (@ 10 kHz, typical)
- Connector type:**
• BNC (F)

Dc control source

- Dc voltage level:**
• 0 to +20 V (20 mA max.)
- Option 001:**
• -15 to +35 V (20 mA max.)
- Dc voltage resolution:**
• 100 μV
- Dc voltage accuracy:**
• $\pm(0.1\% + 2 \text{ mV})$
- Noise density:**
• $< 1 \text{ nV}/\sqrt{\text{Hz}}$ (@ 10 kHz, typical)
- Settling time:**
• $< 20 \text{ msec}$ at 0.1 % error (typical)
- Output resistance (dc):**
• $< 10 \Omega$ (typical)
- Connector type:**
• BNC (F)

1 kHz signal source

- Frequency:**
• 1 kHz
- Level:**
• 0 to 1 Vrms (@ open load)
- Level resolution:**
• 1 mVrms
- Level accuracy:**
• 1 mVrms
- Output impedance:**
• 50 Ω nominal (typical)
- Connector type:**
• BNC (F)

Receiver characteristics

- Frequency range:**
• 10 MHz to 3 GHz
- Input level:**
• -10 to +20 dBm
- Input Impedance:**
• 50 Ω
- SWR:**
• < 1.2 (@ $< 2 \text{ GHz}$),
• < 1.3 (@ 2 to 3 GHz)
- Connector type:**
• N-type (F)

Measurement parameters

RF power

- Input level:**
• -10 to +20 dBm
- Resolution:**
• 0.01 dB
- Accuracy:**
• $\pm 0.6 \text{ dB}$ (@ $\leq 2 \text{ GHz}$, $\leq 15 \text{ dBm}$)
• $\pm 1 \text{ dB}$ (@ other conditions)
• $\pm 0.2 \text{ dB}$ (@ 1 GHz, -5 dBm, typical)

- Number of measurement points per sweep (analyzer mode):**
• 2 to 801 points

Note: cable loss compensation

The 4352B can compensate for the RF power level loss of the cable connecting the DUT output terminal and the 4352B RF IN connector when measuring RF power.

Frequency

- Resolution:**
• 1 kHz
- Accuracy:**
• $\pm(1 \text{ kHz} + \text{Time base accuracy of the external signal generator})$
- Number of measurement points per sweep (analyzer mode):**
• 2 to 801 points

Phase noise (carrier-to-noise ratio)

- Offset frequency range:**
• 100 Hz to 10 MHz

Noise floor:

Offset frequency	Spec	Typical
100 Hz	-85 dBc/Hz	-90 dBc/Hz
1 kHz	-110 dBc/Hz	-117 dBc/Hz
10 kHz	-130 dBc/Hz	-137 dBc/Hz
100 kHz	-140 dBc/Hz	-147 dBc/Hz
1 MHz	-150 dBc/Hz	-157 dBc/Hz

Note: The phase noise of signal generator isn't included in these values.

Accuracy:

- $\pm 4 \text{ dB}$ @ 100 Hz - 1 kHz (typical)
- $\pm 2 \text{ dB}$ @ 1 kHz - 1 MHz
- $\pm 4 \text{ dB}$ @ 1 MHz - 10 MHz

Spectrum

- Span:**
• 10 MHz (Max.)
- Resolution band width:**
• 1 Hz to 3 kHz (1, 3 step)
- Noise floor:**
• $< -95 \text{ dBm}$ (@ RBW = 30 Hz, typical)
• $< -75 \text{ dBm}$ (@ RBW = 3 kHz, typical)
- Absolute level accuracy:**
• $\pm 2 \text{ dBm}$ (@ -5 dBm, typical)
- Relative level accuracy:**
• $\pm 1.5 \text{ dB}$
• $\pm 0.5 \text{ dB}$ (typical)

Frequency transient

- Frequency range:**
- 100 MHz to 3 GHz measurement range (frequency span)
 - 2 MHz, 20 MHz, MAX (see table 1)
- Frequency resolution:**
- Measurement range ÷ 40000 [Hz]
- Frequency accuracy:**
- $\pm(\text{Measurement range} \times 0.1\% + \text{Time base accuracy of the external signal generator})$
- Number of measurement points per sweep:**
- 2 to 801 points
- Minimum sampling interval:**
- 12.5 μsec
- Maximum sweep time:**
- 10 sec
- Sampling start delay:**
- 0 to 800 msec
- Time base accuracy:**
- Time base accuracy of the external signal generator

FM deviation

- Measurement range:**
- 2 kHz, 20 kHz, 200 kHz
- Resolution:**
- 4 digits
- Accuracy:**
- $\pm(2\% \text{ of reading} + 0.5\% \text{ of measurement range})$
 - $\pm 0.8\%$ (typical after FM deviation cal.)
- Detection filter:**
- HP filter: 50 Hz, 300 Hz
 - LP filter: 3 kHz, 15 kHz, 20 kHz
- Residual FM:**
- $< 3 \text{ Hzrms} (@ 300 \text{ Hz} - 3 \text{ kHz bandwidth})$

Dc power current

- Current range:**
- 0 to 50 mA
- Accuracy:**
- $\pm(0.2\% \text{ of reading} + 100 \mu\text{A})$

General characteristics

- Display:**
- 9 inch, color LCD
- Data storage:**
- Built-in 3.5" flexible disk drive (720 kB or 1.44 MB)
 - Volatile RAM disk memory (512 kB)
- Disk format:**
- LIF, MS-DOS®
- File type:**
- Instrument state - BINARY
 - Data and memory - ASCII, BINARY
 - Graphics - TIFF

Interfaces

External input (LO IN)

- Connector: N (f)
- Level: +10 dBm

24-bit parallel digital I/O port

- Connector: D-SUB (36-pin)
- Level: TTL
- I/O: 8-bit I/O, 16-bit output
- PASS/FAIL signal, SWEEP END signal, Trigger sync signal

External trigger input

- Connector: BNC (f)
- Level: TTL

External program RUN/CONT input

- Connector: BNC (f)
- Level: TTL

External monitor output

- Connector: D-SUB (15-pin)
- Output signal: VGA (640 x 480)

Printer interface

- Interface: Centronics
- Control language: HP PCL3

GPIB

Operating conditions

- Temperature:**
- 10°C to +40°C
- Humidity:**
- 15% to 80% RH
- Power requirements:**
- 90 V to 132 V or 198 V to 264 V, 47 Hz to 63 Hz, 300 VA max
- Size:**
- 425 mm (W) x 235 mm (H) x 553 mm (D)
- Weight (typical):**
- 21.5kg

Table 1. Measurement range in DIRECT mode

	1	2	3	4	5	6	7	8
Measurement range (MHz)	128	256	384	512	640	768	896	1024
RF MAX (MHz)	192	384	576	768	960	1152	1354	1536
RF MIN (MHz)	64	128	192	256	320	384	448	512
Freq. resolution (kHz)	3.2	6.4	9.6	12.8	16	19.2	22.4	25.6
	9	10	11	12	13	14	15	16
Measurement range (MHz)	1152	1280	1408	1536	1664	1792	1920	2048
RF MAX (MHz)	1728	1920	2112	2304	2496	2688	2880	3000
RF MIN (MHz)	576	640	704	768	832	896	960	1024
Freq. resolution (kHz)	28.8	32	35.2	38.4	41.6	44.8	48	51.2

Agilent 43521A Downconverter Unit Specification

RF-in port:

Connector: N(f)
Frequency: 10 MHz to 12.6 GHz

RF power (heterodyne path):

Input VSWR: < 1.5
Frequency: 2.4 GHz to 12.6 GHz
Level:
@ ATT = 0 dB -20 dBm to 0 dBm
@ ATT > 0 dB -20 dBm to +20 dBm
Resolution: 0.01 dBm
Accuracy: (@ 23°C ±10°C)
@ ≤ 15 dBm: ±1.5 dB @ ≤ 4 GHz
±2.0 dB @ ≤ 8 GHz
±2.5 dB @ ≤ 12.6 GHz
@ ≤ 20 dBm: ±1.5 dB @ ≤ 4 GHz (SPC*)
±2.0 dB @ ≤ 8 GHz (SPC*)
±2.5 dB @ ≤ 12.6 GHz (SPC*)
@ -5 dBm, ± 0.8 dB @ 6 GHz (typical)
@ -5 dBm, ± 1.0 dB @ 12 GHz (typical)

Heterodyne path gain:
20 dB @ 6 GHz (SPC*)
Direct path insertion loss:
0.5 dB @ 3 GHz (SPC*)

LO-in port:

Connector: N(f)
Input level: +10 dBm nominal
Frequency range:
10 MHz to 6 GHz
LO-in direct path insertion loss:
0.5 dB @ 3 GHz (SPC*)

LO-out port:

Connector: N(f)
600 MHz output level:
≥ 8 dBm (SPC*)
600 MHz accuracy:
600 MHz ± 50 ppm (SPC*)
Operating conditions:
Power requirements:
90 V to 132 V or 198 V to 264 V,
47 Hz to 63 Hz, 100 VA max
Size:
425 mm (W) x 101 mm (H) x
553 mm (D)
Weight:
8 kg (typical)

System performance with 43521A

The system performance is the capacity achieved by the combination of the 4352B, the signal generator, and the 43521A when the 43521A is phase-locked to the 40 MHz on the 4352B under 23°C ±10°C. All data except for RF power measurement (heterodyne path) are SPC*

1. Direct path (10 MHz to 3 GHz)

RF power:
Add ±0.1 dB to 4352B spec. (@ ≤ 2 GHz)
Add ±0.2 dB to 4352B spec. (@ 2 GHz < Freq. ≤ 3 GHz)
Other parameters:
Same as the 4352B spec.

2. Heterodyne path (2.4 GHz to 12.6 GHz)

2-1. Tester mode

RF power Same as 43521A spec.
Frequency
Frequency range:
2.4 GHz to 12.6 GHz
Resolution: Same as 4352B spec.
Accuracy: Same as 4352B spec.
FM deviation
Measurement range:
Same as 4352B spec.
Resolution: Same as 4352B spec.
Accuracy: Same as 4352B spec.
Residual FM Same as 4352B spec.
Phase noise (C/N ratio)
Offset frequency range:
100 Hz to 10 MHz
Noise floor (when used with the Agilent 8665B** up to 12.6 GHz. ≤ 6GHz when used with the Agilent 8664A**.): See figure.
Accuracy: Same as 4352B spec.

2-2. Analyzer mode

RF power Same as the 43521A spec.
Frequency Same as the tester mode spec.
Phase noise (C/N ratio)
Same as the tester mode spec.
Frequency transient
Frequency range:
2 MHz, 20 MHz, 512 MHz
Frequency accuracy:
±(measurement range x 0.1% + Time base accuracy of the external signal generator)
Resolution: 50 Hz, 500 Hz, 12.8 kHz
Spectrum
Absolute accuracy:
±3 dBm @ -10 dBm,
RF ATT=10 dB
Relative accuracy:
Same as the 4352B spec.

*: SPC = Supplemental performance characteristics

** : with Option 004

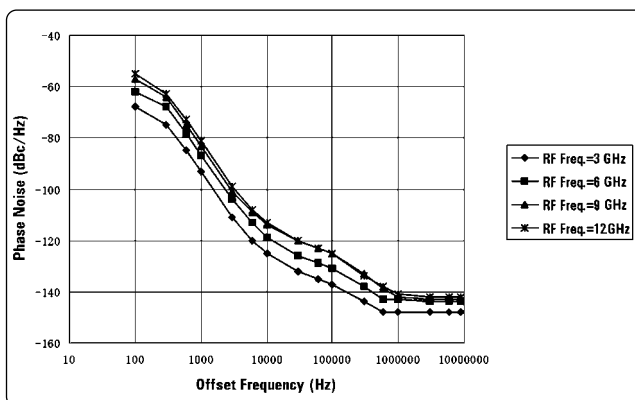

Typical phase noise performance using 43521A

Ordering Information

Agilent 4352S VCO/PLL signal test system

Agilent 4352B VCO/PLL signal analyzer

Furnished accessories:

- Operation manual set
- BNC-BNC cable (60 cm) (P/N 8120-1839)
- N-N cable (P/N 41951-61602)
- GPIB cable (P/N 10833A)
- Keyboard (P/N C3757-60401)
- Power cable

Option

- | | |
|------------|---|
| 001 | Expand dc control voltage |
| 1A2 | Delete keyboard |
| 1CM | Rack mount kit |
| 1CN | Handle kit |
| 1CP | Rack mount & handle kit |
| ABA | English localization |
| ABJ | Japanese localization |
| 0B0 | Delete manual set (Note: Language selection depends on option ABA or ABJ) |
| 0B1 | Add manual set |
| UK6 | Commercial cal. certificate with test data |

Guideline of signal generator selection

The recommended signal generators

Agilent 8664A with Option 004 (enhanced spectral purity)

Frequency: 100 kHz to 3 GHz
Phase noise: -135 dBc/Hz (@ 10 kHz offset, 1 GHz carrier)

Agilent 8665B with Option 004 (enhanced spectrum purity)

Frequency: 100 kHz to 6.0 GHz
Phase noise: -135 dBc/Hz (@ 10 kHz offset, 1 GHz carrier)

E8241A/E8251A with Option UNJ (improved phase noise) and 1ED (Type-N RF output connector)

Frequency: 250 kHz to 20 GHz
Phase Noise: -135 dBc/Hz (@ 10 kHz offset, 1 GHz carrier)

You can select the best signal generator based on your VCO requirements. Here is the selection guideline for signal generators.

1. Choose the signal generator which covers the frequency range of your VCO requirements.
2. Choose the signal generator which has at least 5 dB better phase noise performance than your VCO at the same offset frequency.
3. Choose the correct signal generator options if needed.

Note: Refer to Signal Generator Selection Guide (P/N 5091-7274E) or the specific signal generator technical data sheet for more information

Note: Signal generators other than recommended Agilent Technologies signal generators can be used with the 4352B. Please contact Agilent Technologies' sales office for details. Typical phase noise performance of the 4352B and recommended signal generators (@ 1 GHz carrier).

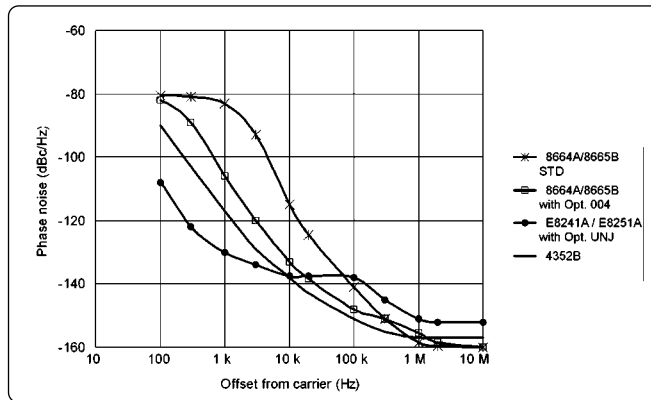

Typical phase noise performance of the Agilent 4352B and recommended signal generators. (@ 1 GHz carrier)

Table 2. The 4352S phase noise measurement error

Device	4352B	Sig. Gen.	Reading	Error
-120	-140	-130	-119.55	0.45
-115	-140	-120	-113.8	1.2
-130	-135	-135	-127.87	2.13

Downconverter Specification When the Phase Noise Characteristics are Evaluated Above 12.6 GHz

Agilent 43521A downconverter unit

Furnished accessories:

- N-N cable (18 cm), 2 ea. (P/N 8120-4387)
- N-N cable (50 cm), 1 ea. (P/N 43521-61638)
- BNC-BNC cable (30 cm) (P/N 8120-1838)
- 15-Pin D-Sub cable (P/N 04380-61601)
- Operation manual
- Power cable

Options:

- 1CM Rackmount kit
- 1CN Handle kit
- 1CP Rackmount kit & handle kit
- ABA English localization
- ABJ Japanese localization
- 0B0 Delete operation manual
- 0B1 Add operation manual
- UK6 Commercial cal. certificate with test data

Recommended signal generator when the 43521A is used with the system

The following signal generators are recommended when the 43521A is used with the standard system.

Signal generator	Frequency range with the 4352B, 43521A
8664A	10 MHz to 6.6 GHz
8665B	10 MHz to 12.6 GHz
E8241A	10 MHz to 12.6 GHz
E8251A	10 MHz to 12.6 GHz

The typical phase noise performance of the 4352B, the 43521A, and the above recommended signal generators is shown in "System Performance with 43521A" on page 13.

Agilent 8664A with Option 004 (enhanced spectrum purity)

Frequency: 100 kHz to 3 GHz
 Phase noise: -135 dBc/Hz (@ 10 kHz offset, 1 GHz carrier)
 System frequency range of Agilent 4352S: 10 MHz to 6.6 GHz

Agilent 8665B with Option 004 (enhanced spectrum purity)

Frequency: 100 kHz to 6.0 GHz
 Phase noise: -135 dBc/Hz (@ 10 kHz offset, 1 GHz carrier)
 System frequency range of 4352S: 10 MHz to 12.6 GHz

E8241A/E8251A with Option UNJ (improved phase noise) and 1ED (Type-N RF output connector)

Frequency: 250 kHz to 20 GHz
 Phase noise: -135 dBc/Hz (@ 10 kHz offset, 1 GHz carrier)
 System frequency range of 4352S: 10 MHz to 12.6 GHz

Phase noise measurement up to 26.5 GHz

When the following downconverters are used with the 4352S, the phase noise characteristics can be evaluated up to 26.5 GHz. You have to select either the Agilent 70004A (MMS color display) with the Agilent 70422A or the Agilent 70004A with the Agilent 70427A.

The typical phase noise performance for each downconverter is as shown below.

Model	Frequency range	Test signal level
70422A	1 GHz to 18 GHz	+5 dBm to +15 dBm @ ≤ 12 GHz
+70004A		+10 dBm to +15 dBm @ ≤ 12 GHz
70427A	1.5 GHz to 26.5 GHz	-40 dBm to +30 dBm
+70004A (= 71707A)		

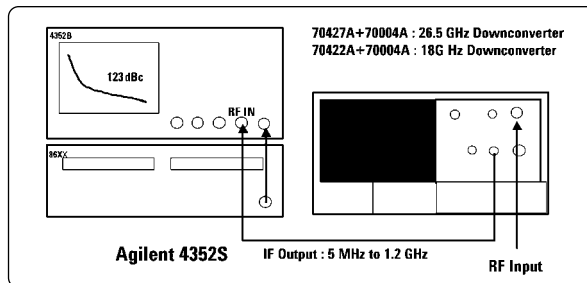

System configuration when the downconverter is used

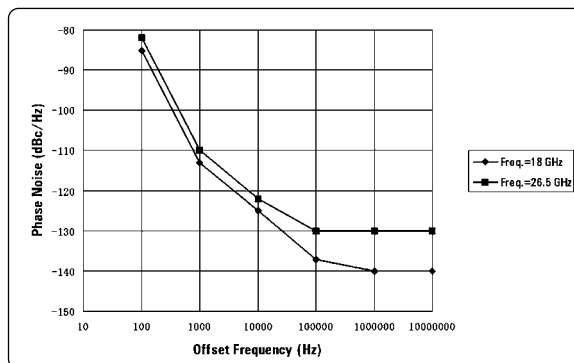

Typical phase noise performance (noise floor) with downconverter



www.agilent.com/find/emailupdates
Get the latest information on the products and applications you select.



www.agilent.com/find/agilentdirect
Quickly choose and use your test equipment solutions with confidence.



www.agilent.com/find/open
Agilent Open simplifies the process of connecting and programming test systems to help engineers design, validate and manufacture electronic products. Agilent offers open connectivity for a broad range of system-ready instruments, open industry software, PC-standard I/O and global support, which are combined to more easily integrate test system development.

www.agilent.com

Agilent Technologies' Test and Measurement Support, Services, and Assistance

Agilent Technologies aims to maximize the value you receive, while minimizing your risk and problems. We strive to ensure that you get the test and measurement capabilities you paid for and obtain the support you need. Our extensive support resources and services can help you choose the right Agilent products for your applications and apply them successfully. Every instrument and system we sell has a global warranty. Two concepts underlie Agilent's overall support policy: "Our Promise" and "Your Advantage."

Our Promise

Our Promise means your Agilent test and measurement equipment will meet its advertised performance and functionality. When you are choosing new equipment, we will help you with product information, including realistic performance specifications and practical recommendations from experienced test engineers. When you receive your new Agilent equipment, we can help verify that it works properly and help with initial product operation.

Your Advantage

Your Advantage means that Agilent offers a wide range of additional expert test and measurement services, which you can purchase according to your unique technical and business needs. Solve problems efficiently and gain a competitive edge by contracting with us for calibration, extra-cost upgrades, out-of-warranty repairs, and onsite education and training, as well as design, system integration, project management, and other professional engineering services. Experienced Agilent engineers and technicians worldwide can help you maximize your productivity, optimize the return on investment of your Agilent instruments and systems, and obtain dependable measurement accuracy for the life of those products.

For more information on Agilent Technologies' products, applications or services, please contact your local Agilent office.

Phone or Fax

United States:

(tel) 800 829 4444
(fax) 800 829 4433

Canada:

(tel) 877 894 4414
(fax) 800 746 4866

China:

(tel) 800 810 0189
(fax) 800 820 2816

Europe:

(tel) 31 20 547 2111

Japan:

(tel) (81) 426 56 7832
(fax) (81) 426 56 7840

Korea:

(tel) (080) 769 0800
(fax) (080) 769 0900

Latin America:

(tel) (305) 269 7500

Taiwan:

(tel) 0800 047 866
(fax) 0800 286 331

Other Asia Pacific Countries:

(tel) (65) 6375 8100

(fax) (65) 6755 0042

Email: tm_ap@agilent.com

Contacts revised: 09/26/05

**The complete list is available at:
www.agilent.com/find/contactus**

Product specifications and descriptions in this document subject to change without notice.

© Agilent Technologies, Inc. 2001, 2006
Printed in USA, July 13, 2006
5966-0805E

MS-DOS® is a U.S. registered trademark of Microsoft Corp.

