

# Agilent 85108A/L CW/Pulsed Network Analyzer Systems

Product Overview

## Discontinued Product Information — For Support Reference Only —

Information herein, may refer to products/services no longer supported. We regret any inconvenience caused by obsolete information. For the latest information on Agilent's test and measurement products go to: [www.agilent.com/find/products](http://www.agilent.com/find/products)

**In the US, call Agilent Technologies at 1-800-829-4444**  
(any weekday between 8am–5pm in any U.S. time zone)

World-wide Agilent sales office contact information is available at:  
[www.agilent.com/find/contactus](http://www.agilent.com/find/contactus)

### Agilent 85108A, 2 to 20 GHz Agilent 85108L, 0.045 to 2 GHz Optional 50 GHz system

- Wide dynamic range for accurate pulsed measurements
- Low duty cycles allow high-power measurements of on-wafer or in-fixture devices
- Up to 100 W pulsed device output power and CW power up to 20 W (85108A) or 50 W (85108L)

These Agilent Technologies 8510C-based component measurement systems provide high performance to meet your new design and test challenges. The 85108A/L feature a complete configuration for high-volume, high-power, and pulsed-RF testing of components and devices at IF, RF, and microwave frequencies.

The Agilent 85108A/L network analyzer systems have been designed to measure high-power devices under both constant-power and pulsed-power conditions.

These systems are built around the Agilent 8510C with the pulsed-RF measurement option (Option 008). This option allows the 8510C to perform pulse profile network analysis of devices that require a pulsed-RF stimulus.

Other measurement capabilities such as spectral analysis, noise figure, and load pull can be added easily without degradation of the raw system performance.



**Agilent 85108A/L systems provide capabilities for high-power and pulsed applications.**



**Agilent Technologies**

## Agilent 8510C Option 008

The 8510C with pulsed-RF measurement capability (Option 008) includes an additional receiver subsystem. This pulsed-RF measurement capability, which exists in parallel with the standard 8510C operation, provides you with the ability to measure and display the relative magnitude and phase shift of the component as a function of time with an equivalent bandwidth of 1.5 MHz. This allows the evaluation of the dynamic pulsed-RF characteristics for pulse widths down to 1 microsecond.

## High-power measurements

The pulsed-RF network (Option 008) analyzers have been designed to measure high-power devices under both constant-power and pulsed-power conditions.

There are two major issues to resolve when measuring high-power devices:

- providing the proper RF drive level to the device-under-test (DUT)
- limiting the power signal from the DUT to levels below the 0.1 dB-compression point of the network analyzer

Any amplifier added to boost the signal power level to the DUT must be placed behind the network analyzer test set's port 1 couplers to remove its effects from the measurements. This can easily be accomplished with the open architecture design of the pulse test sets.

Real-time pulsed-RF and swept-frequency measurements are possible without the use of an external computer.

## Pulsed-RF measurements

Using the Agilent 8510C, with its wide IF bandwidth option (Option 008), swept-frequency pulse testing can be done with the press of a single key, and in real-time. The analyzer includes an internal pulse generator, or an external pulse generator can be used to provide the pulse widths and duty cycles your device requires. A flexible, external-trigger input gives you fully asynchronous control over data acquisition while pulsing from an external source.

In addition to swept-frequency testing, the 8510C Option 008 wideband detectors also permit analysis of a device's dynamic behavior during a pulse at a single RF frequency using repetitive sampling. In this "Pulse Profile" domain, the analyzer displays the DUT's S-parameters as a function of time on a real-time, continuously updated display. The wide IF bandwidth of 1.5 MHz permits rapid data acquisition, allowing much faster profiling of the DUT's magnitude and phase behavior than with other pulsed network analyzer systems.



**The Agilent 85108 A/L offer pulsed-RF measurements in frequency and time domain.**

## Wide dynamic range

Unlike other pulsed systems, the pulsed dynamic range of the Agilent 85108A/L systems is independent of the applied duty cycle. So whether your duty cycle is 1% or 90%, the system dynamic range at 20 GHz is 60 dB. For CW signals, system dynamic range is 75 dB at 20 GHz (expandable to 50 GHz with dynamic range greater than 62 dB for CW signals). This wide dynamic range allows for accurate pulsed measurements at any duty cycle.

## 50 GHz measurement capabilities

The increased demand for devices to operate at higher frequencies has driven the need for test systems above 20 GHz. By extending the frequency coverage of the 85110A test set, Agilent is able to provide systems that are capable of both CW and pulsed-RF measurements to 50 GHz. Similar to the 20 GHz systems, the 50 GHz systems are ideal for high-power and pulsed-RF testing of components.

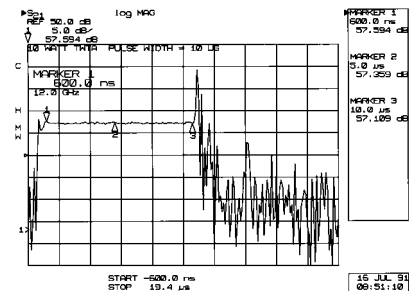

**Analyze the dynamic behavior of your device versus time at real-time update rates, with full two-port error correction.**

### The Agilent 85110A/L test set

An Agilent 85110A or 85110L S-parameter test set is a required system component for the pulsed network analyzer systems. These test sets provide a fundamentally mixed, low-noise IF to the receiver, and can also be used as downconverters for other external receivers at IF frequencies up to 200 MHz.

Direct access to the RF path via jumpers on the rear panel allows single-connection, multiple-measurement (SCMM) systems to be configured, enabling multiple types of measurements through a single RF connection to the DUT. With internal step attenuators at each mixer RF input, and the use of high-power directional couplers, the test set can measure at RF power levels of up to 20 watts CW (50 watts CW with the Agilent 85108L).

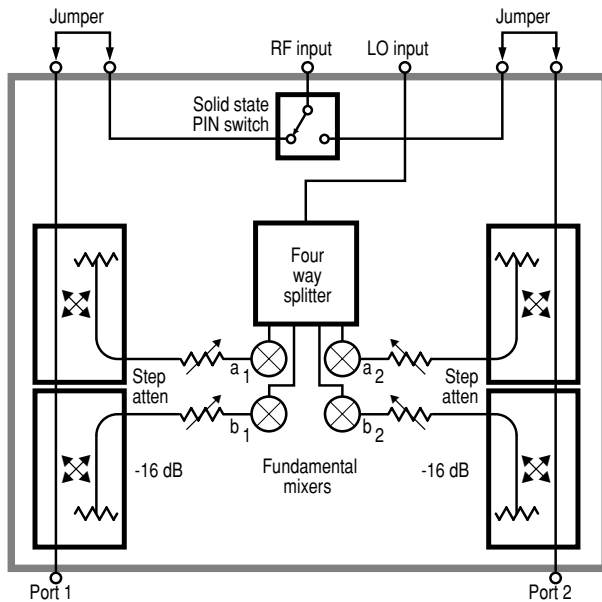

**The Agilent 85110A test set permits high power handling and direct RF access.**

With its open architecture, the Agilent 85110A/L is an ideal platform for customized configurations to serve your specific application needs.

### High power network analysis to 110 GHz

Agilent pulsed-RF network analyzers have been designed to measure high-power devices under either constant-power or pulsed-power conditions while sweeping the frequency range of 2 to 50 GHz in coax, and 50 to 75 GHz or 75 to 110 GHz in waveguide. The test set's open architecture allows:

- the addition of amplifiers, if necessary, to boost RF signal levels delivered to devices
- the direct measurement of power levels up to +60 dBm (peak)

### Factory system integration

Each system is fully integrated at Agilent, then installed at your site. With Agilent's ongoing local system support, you are ensured of higher system uptime and lower long-term risk. Your own resources can be applied to innovative product development and improving manufacturing yields.

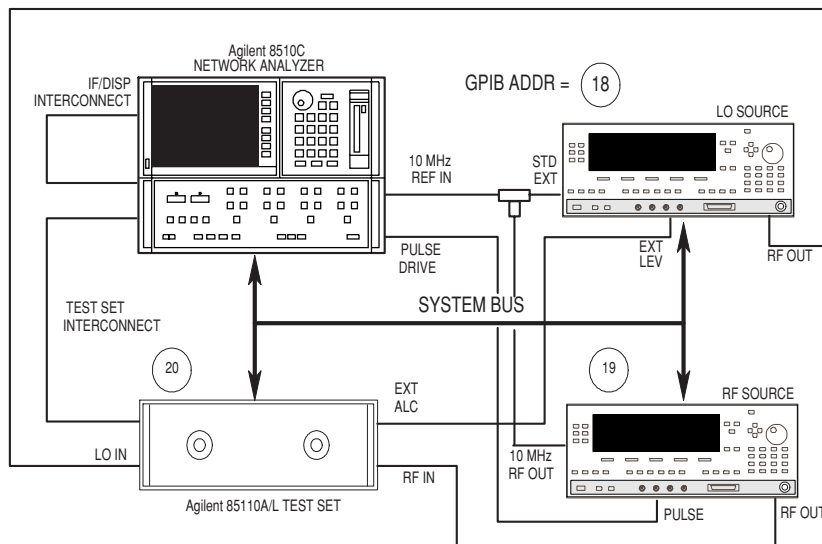

**Fully factory-integrated Agilent 85108A/L systems**

## Agilent 85108A system performance

The following specifications describe the system performance of the Agilent 8510C network analyzer in the 85108A (2 to 20 GHz) configuration. The following hardware was used to generate the specifications:

**Test set:** Agilent 85110A

**RF sources:** Agilent 83622B and 83623L synthesized sweepers (one each)

**Calibration kit:** Agilent 85052B, 3.5 mm calibration kit

**Calibration technique:** Sliding load two-port calibration

**Dynamic range<sup>1</sup>** (for transmission measurements, independent of duty cycle)

	Frequency Range (GHz)		
	2 to 8	8 to 18	18 to 20
Maximum power measured at port 2	+11 dBm	+11 dBm	+11 dBm
Reference power at port 1 (nominal)	0 dBm	-1 dBm	-2 dBm
Minimum power measured at port 2			
(pulsed)	-64 dBm	-63 dBm	-62 dBm
(cw)	-78 dBm	-78 dBm	-77 dBm
Receiver dynamic range			
(pulsed)	75 dB	74 dB	73 dB
(cw)	89 dB	89 dB	88 dB
System dynamic range			
(pulsed)	64 dB	62 dB	60 dB
(cw)	78 dB	77 dB	75 dB

**Specifications** describe the instrument's warranted performance over the temperature range of 23°C ±3°C (except where noted).

**Supplemental characteristics** are intended to provide useful instrument applications information by giving typical but non-warranted performance parameters. These are denoted as "typical," "nominal," or "approximately."

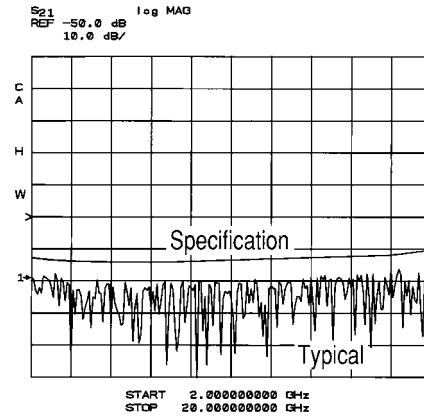

System dynamic range

## Measurement uncertainty

### Reflection measurements

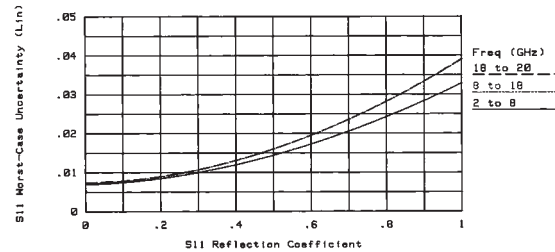

Magnitude

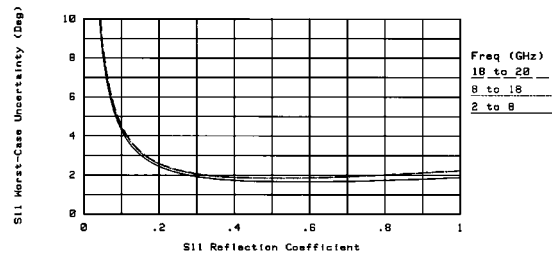

Phase

### Transmission measurements

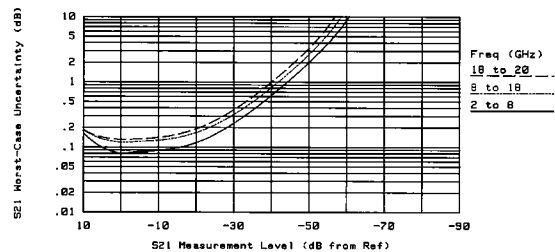

Magnitude

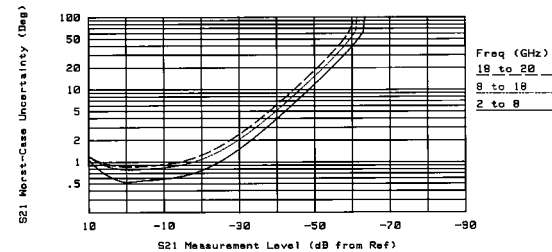

Phase

## Measurement port characteristics

(with wideband detectors)

RESIDUAL	Frequency Range (GHz)		
	2 to 8	8 to 18	18 to 20
Directivity	44 dB	44 dB	44 dB
Source match	33 dB	31 dB	31 dB
Load match	44 dB	44 dB	44 dB
Reflection tracking	±0.003 dB	±0.006 dB	±0.006 dB
Transmission tracking	±0.044 dB	±0.084 dB	±0.094 dB
Crosstalk <sup>2</sup>	64 dB	62 dB	61 dB

## Pulsed-RF detectors

**Equivalent measurement bandwidth (-3 dB):** 1.5 MHz

**Aperture uncertainty:** < 1 nanosecond (typical)

**Transition time (10% to 90%):** 300 nanoseconds

**Trigger level (external):** TTL (falling edge)

**Trigger width (minimum):** 100 nanoseconds

**Minimum time display:** 5 microseconds

**Maximum time display:** 40 milliseconds

- Limited by compression level and system noise floor. Noise floor is measured with full two-port error correction, 1024 averages.
- Does not include noise.

## Agilent 85108L system performance

The following specifications describe the system performance of the Agilent 8510C network analyzer in the 85108L (.045 to 2 GHz) configuration. The following hardware was used to generate the specifications:

**Test set:** Agilent 85110L

**RF sources:** Agilent 83620B Option H80 synthesized sweeper (two each)

**Calibration kit:** Agilent 85050D, 7 mm calibration kit

**Calibration technique:** Broadband load two-port calibration

**Dynamic range<sup>1</sup>** (for transmission measurements, independent of duty cycle)

	Frequency Range (GHz)		
	0.045 to 0.1	0.1 to 0.5	0.5 to 2
<b>Maximum power</b> measured at port 2	+20 dBm	+6 dBm	+5 dBm
<b>Reference power</b> at port 1 (nominal)	0 dBm	+1 dBm	0 dBm
<b>Minimum power</b> measured at port 2			
(pulsed)	-53 dBm	-66 dBm	-66 dBm
(cw)	-81 dBm	-95 dBm	-96 dBm
<b>Receiver dynamic range</b>			
(pulsed)	72 dB	72 dB	72 dB
(cw)	101 dB	101 dB	100 dB
<b>System dynamic range</b>			
(pulsed)	53 dB	67 dB	66 dB
(cw)	81 dB	95 dB	95 dB

## Measurement uncertainty

### Reflection measurements

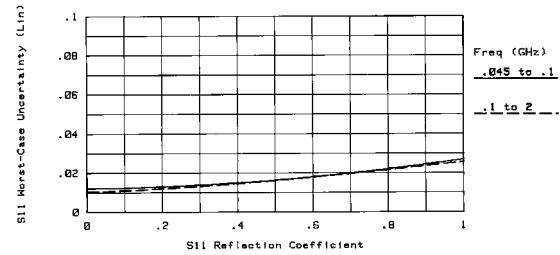

### Magnitude

### Transmission measurements

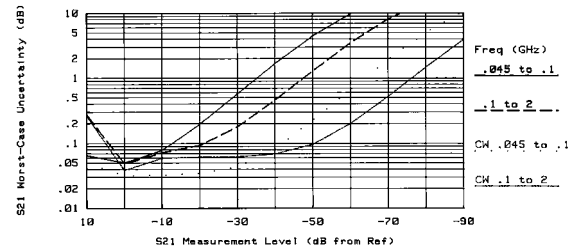

### Magnitude

## Measurement port characteristics

(with wideband detectors)

RESIDUAL	Frequency Range (GHz)		
	0.045 to 0.1	0.1 to 0.5	0.5 to 2
<b>Directivity</b>	40 dB	40 dB	40 dB
<b>Source match</b>	39 dB	39 dB	39 dB
<b>Load match</b>	40 dB	40 dB	40 dB
<b>Reflection tracking</b>	±0.01 dB	±0.01 dB	±0.01 dB
<b>Transmission tracking</b>	±0.0082 dB	±0.0116 dB	±0.0184 dB
<b>Crosstalk<sup>2</sup></b>	54 dB	67 dB	66 dB

**Specifications** describe the instrument's warranted performance over the temperature range of 23°C ±3°C (except where noted).

**Supplemental characteristics** are intended to provide useful instrument applications information by giving typical but non-warranted performance parameters. These are denoted as "typical," "nominal," or "approximately."

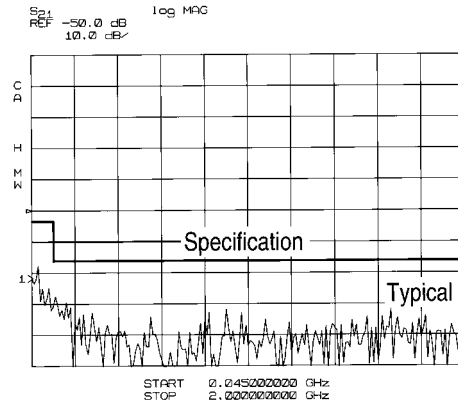

## System dynamic range

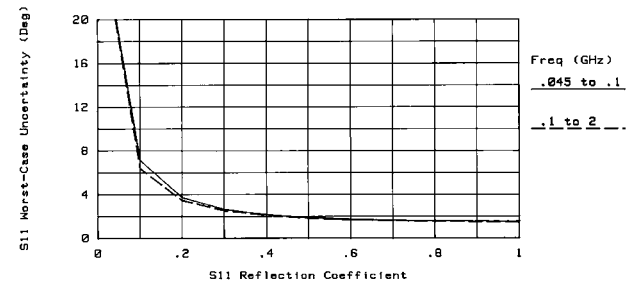

### Phase

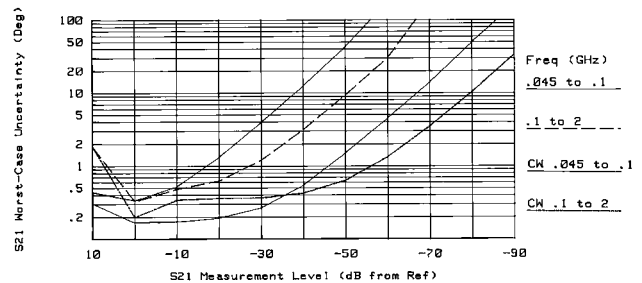

### Phase

## Pulsed-RF detectors

**Equivalent measurement bandwidth (-3 dB):** 1.5 MHz

**Aperture uncertainty:** < 1 nanosecond (typical)

**Transition time (10% to 90%):** 300 nanoseconds

**Trigger level (external):** TTL (falling edge)

**Trigger width (minimum):** 100 nanoseconds

**Minimum time display:** 5 microseconds

**Maximum time display:** 40 milliseconds

1. Limited by compression level and system noise floor. Noise floor is measured with full two-port error correction, 1024 averages.
2. Does not include noise.

### Optional 50 GHz system(s)

The 50 GHz 85108A system is available by contacting your local Agilent field office. This is a factory-integrated system that provides the entire configuration required to make pulsed-RF measurements from 1 to 50 GHz. This 50 GHz system includes the Agilent 8510C with Option 008, a 50 GHz 85110A test set, a 50 GHz synthesized sweeper for the RF source, and a 20 GHz synthesized sweeper for the LO source.

Since a 20 GHz synthesized sweeper is used as an LO source in a 50 GHz system, the LO source must operate in either fundamental mode or third-harmonic mode depending on frequency of operation. When sweeping from 1 to 20 GHz, the LO source must be set to fundamental mode.

When sweeping to 50 GHz, the LO source must be set to third-harmonic mode, putting the start frequency at 6 GHz or higher. As a result, the operating frequency of this system is either 1 to 20 GHz, or 6 to 50 GHz.

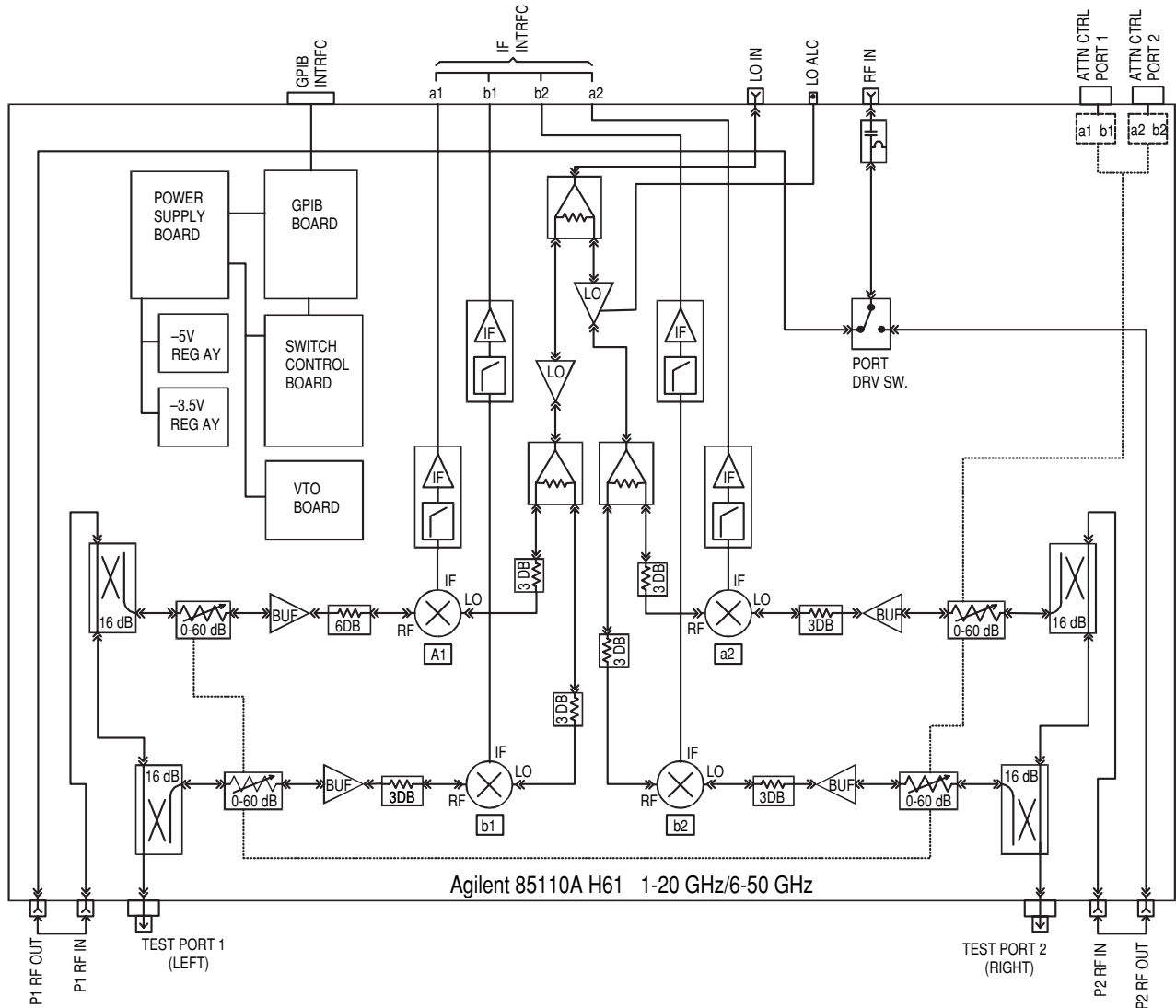

**The Agilent 85110A Option H61 50 GHz test set is the key to the 50 GHz 85108A system.**

## Optional 1 to 50 GHz CW/pulsed VNA system characteristics

The following characteristics describe the performance of the 50 GHz Agilent 85108A CW/pulsed system. The following system configuration was used to generate the characteristics:

**Test set:** Agilent 85110A Option H60<sup>1</sup>, 50 GHz mixer-based S-parameter test set

**RF source:** Agilent 83650B, 50 GHz synthesized sweeper

**LO source:** Agilent 83620B, 20 GHz synthesized sweeper

**Calibration kit:** Agilent 85056A, 2.4 mm calibration kit

**Calibration technique:** Full two-port calibration

**Dynamic range<sup>2</sup>** (for transmission measurements, independent of duty cycle)

	Frequency range (GHz)			
	1 to 20 <sup>3</sup>	6 to 20 <sup>4</sup>	20 to 40 <sup>4</sup>	40 to 50 <sup>4</sup>
<b>Maximum power (in)</b> measured at port 2	-15 dBm	-2 dBm	-2 dBm	-2 dBm
<b>Reference power (out)</b> measured at port 1	-15 dBm	-12 dBm	-19 dBm	-26 dBm
<b>Minimum power (in)</b> measured at port 2				
(pulsed)	-85 dBm	-81 dBm	-71 dBm	-65 dBm
(CW)	-110 dBm	-104 dBm	-94 dBm	-88 dBm
<b>Receiver dynamic range</b>				
(pulsed)	70 dB	79 dB	69 dB	63 dB
(CW)	95 dB	102 dB	92 dB	86 dB
<b>System dynamic range</b>				
(pulsed)	70 dB	69 dB	52 dB	39 dB
(CW)	95 dB	92 dB	75 dB	62 dB

**System characteristics** are intended to provide useful system performance information but are non-warranted. These are subject to change without notice.

1. Test sets 85110A Option H60 and Option H61 are identical except for the placement of the path links. Path links refer to the links from P1 RF OUT to P1 RF IN and from P2 RF OUT to P2 RF IN. Devices such as amplifiers and isolators can be inserted in place of the path links to optimize system performance. Path links are located on the rear panel for the 85110A Option H60, and on the front panel for the Option H61.
2. Limited by compression level and system noise floor. Noise floor is measured with full two-port error correction, 1024 averages.
3. For operation from 1 to 20 GHz, the LO source must be configured in fundamental mode.
4. For operation from 6 to 50 GHz, the LO source must be configured in third-harmonic mode. The MULTIPLIER DENOM. of the LO source must be set to 3, for third-harmonic mode operation.

## Ordering information

<b>85108A</b>	2 to 20 GHz pulsed-RF network analyzer system
<b>85108L</b>	45 MHz to 2 GHz pulsed-RF network analyzer system
<b>Option 010</b>	add time domain capability to 8510C
<b>Option 230</b>	220V/240V line voltage operation
<b>Option W31</b>	add two-years additional on-site service

### Other system components required but not supplied with the 85108A/L standard systems:

Calibration kits  
Test port cables

*See the Agilent Technologies 8510C configuration guide for more information. Contact your local Agilent field office for ordering information on the optional 50 GHz systems.*

## Related literature

*Agilent 8510C Family Network Analyzer Configuration Guide*  
*Agilent 8510C Family Network Analyzer Data Sheet*  
*Agilent 8510 System Solutions Color Brochure*

## Pub. number

5091-8967E  
5091-8484E  
5965-8837E

## www.agilent.com

### Agilent Technologies' Test and Measurement Support, Services, and Assistance

Agilent Technologies aims to maximize the value you receive, while minimizing your risk and problems. We strive to ensure that you get the test and measurement capabilities you paid for and obtain the support you need. Our extensive support resources and services can help you choose the right Agilent products for your applications and apply them successfully. Every instrument and system we sell has a global warranty. Two concepts underlie Agilent's overall support policy: "Our Promise" and "Your Advantage."

#### Our Promise

Our Promise means your Agilent test and measurement equipment will meet its advertised performance and functionality. When you are choosing new equipment, we will help you with product information, including realistic performance specifications and practical recommendations from experienced test engineers. When you receive your new Agilent equipment, we can help verify that it works properly and help with initial product operation.

#### Your Advantage

Your Advantage means that Agilent offers a wide range of additional expert test and measurement services, which you can purchase according to your unique technical and business needs. Solve problems efficiently and gain a competitive edge by contracting with us for calibration, extra-cost upgrades, out-of-warranty repairs, and onsite education and training, as well as design, system integration, project management, and other professional engineering services. Experienced Agilent engineers and technicians worldwide can help you maximize your productivity, optimize the return on investment of your Agilent instruments and systems, and obtain dependable measurement accuracy for the life of those products.

**For more information on Agilent Technologies' products, applications or services, please contact your local Agilent office.**

#### Phone or Fax

##### United States:

(tel) 800 829 4444  
(fax) 800 829 4433

##### Canada:

(tel) 877 894 4414  
(fax) 800 746 4866

##### China:

(tel) 800 810 0189  
(fax) 800 820 2816

##### Europe:

(tel) 31 20 547 2111

##### Japan:

(tel) (81) 426 56 7832  
(fax) (81) 426 56 7840

##### Korea:

(tel) (080) 769 0800  
(fax) (080) 769 0900

##### Latin America:

(tel) (305) 269 7500

##### Taiwan:

(tel) 0800 047 866

(fax) 0800 286 331

##### Other Asia Pacific Countries:

(tel) (65) 6375 8100

(fax) (65) 6755 0042

Email: [tm\\_ap@agilent.com](mailto:tm_ap@agilent.com)

Contacts revised: 09/26/05

**The complete list is available at:  
[www.agilent.com/find/contactus](http://www.agilent.com/find/contactus)**

Product specifications and descriptions in this document subject to change without notice.

© Agilent Technologies, Inc. 1998, 2000, 2006  
Printed in USA, July 31, 2006  
5091-8965E



### Agilent Email Updates

[www.agilent.com/find/emailupdates](http://www.agilent.com/find/emailupdates)

Get the latest information on the products and applications you select.



### Agilent Direct

[www.agilent.com/find/agilentdirect](http://www.agilent.com/find/agilentdirect)

Quickly choose and use your test equipment solutions with confidence.



[www.agilent.com/find/open](http://www.agilent.com/find/open)

Agilent Open simplifies the process of connecting and programming test systems to help engineers design, validate and manufacture electronic products. Agilent offers open connectivity for a broad range of system-ready instruments, open industry software, PC-standard I/O and global support, which are combined to more easily integrate test system development.



**Agilent Technologies**