

# Agilent 85070D Dielectric Probe Kit

## Product Overview

### Discontinued Product Information — For Support Reference Only —

Information herein, may refer to products/services no longer supported. We regret any inconvenience caused by obsolete information. For the latest information on Agilent's test and measurement products go to: [www.agilent.com/find/products](http://www.agilent.com/find/products)

**In the US, call Agilent Technologies at 1-800-829-4444**  
(any weekday between 8am–5pm in any U.S. time zone)

World-wide Agilent sales office contact information is available at: [www.agilent.com/find/contactus](http://www.agilent.com/find/contactus)

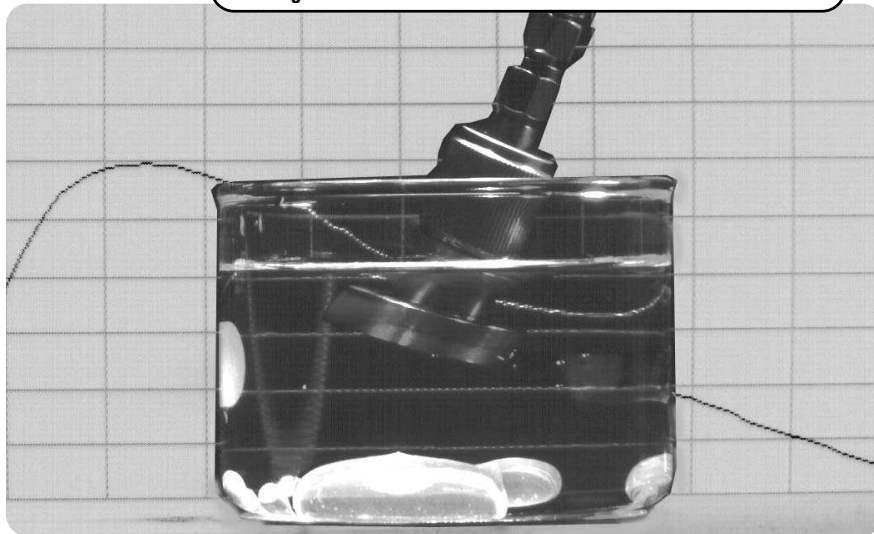

**200 MHz to 20 GHz**

## Features of 85070D

- Runs on a PC, or internally on the PNA Series of network analyzers, eliminating the need for both a PC and a GPIB card.
- Guided calibration and measurement
- Measure permittivity over a broad frequency range (200 MHz to 20 GHz)
- View measurement results in a variety of formats ( $\epsilon_r'$ ,  $\epsilon_r''$ ,  $\tan \delta$  or Cole-Cole)
- Hermetic glass-to-metal seal makes the probe resistant to corrosive or abrasive chemicals.
- Withstands a wide temperature range (-40 °C to +200 °C)
- Compatible with a variety of Agilent network analyzers.
- Component object model (com) interface allows the measurement to be setup, triggered, and read from a user-written program. Example Visual Basic and Visual C++ projects are included to aid program development.



**Agilent Technologies**

## Swept high-frequency dielectric measurements

The 85070D is a dielectric probe that is used to measure the intrinsic electrical properties of materials in the RF and microwave frequency bands.

The 85070D software allows you to measure the complex dielectric constant (also called relative permittivity, or  $\epsilon_r$ ) of liquids and semi-solids, including the dielectric loss factor or loss tangent.

To obtain data at hundreds of frequencies in seconds, simply immerse the probe into liquids or semi-solids – no special fixtures or containers are required. For pliable solids (such as plastics), just press the probe against a flat surface.

The 85070D must be used in conjunction with an Agilent network analyzer. The network analyzer provides the high frequency stimulus, and measures the reflected response.

The probe transmits a signal into the material under test (MUT). The measured reflected response from the material is then related to its dielectric properties. A computer controls the system, and runs software that guides the user through a measurement sequence (computer not included in 85070D).

### 85070D measurement attributes

- Rugged design withstands temperatures from  $-40\text{ }^{\circ}\text{C}$  to  $+200\text{ }^{\circ}\text{C}$ .
- Hermetic glass-to-metal seal resists corrosive chemicals.
- Refresh calibration simplifies measurements over temperature.
- Accessories (cable, short circuit, mounting bracket) improve measurement repeatability.

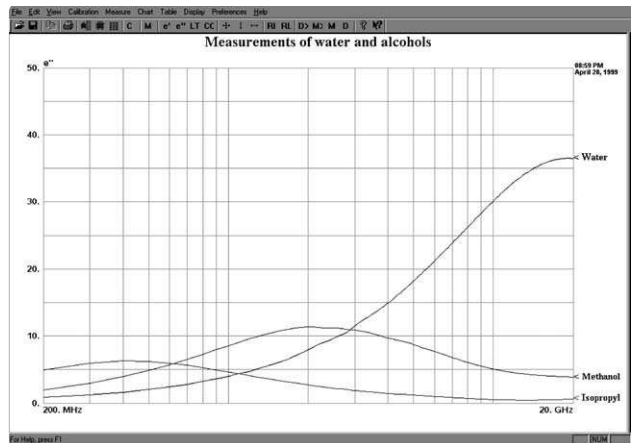
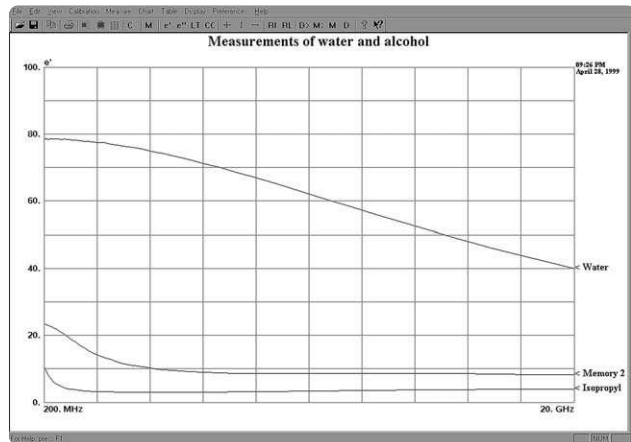

Software displays dielectric constant and loss factor across a 200 MHz to 20 GHz frequency sweep.

## Probe survives corrosive chemicals or high temperatures

The probe features a hermetic glass-to-metal seal, which makes it resistant to corrosive or abrasive chemicals.

The probe withstands a wide  $-40\text{ }^{\circ}\text{C}$  to  $+200\text{ }^{\circ}\text{C}$  temperature range, which allows measurements versus frequency and temperature. This is an important variable, since the dielectric constant of a material can vary significantly as a function of temperature.

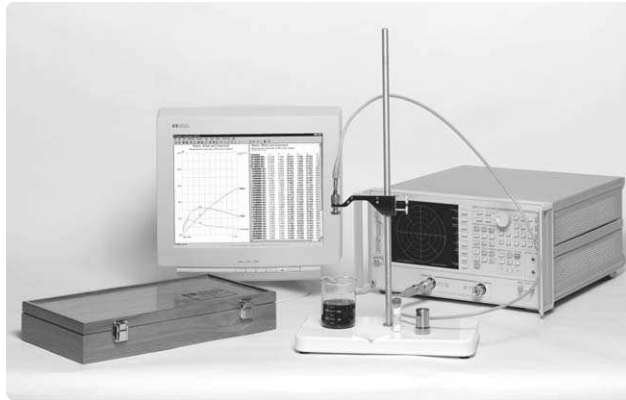

A special refresh calibration feature provides corrected measurements over a wide temperature range. Rather than doing a full calibration at each temperature, a single standard can be used to update or refresh an existing calibration.

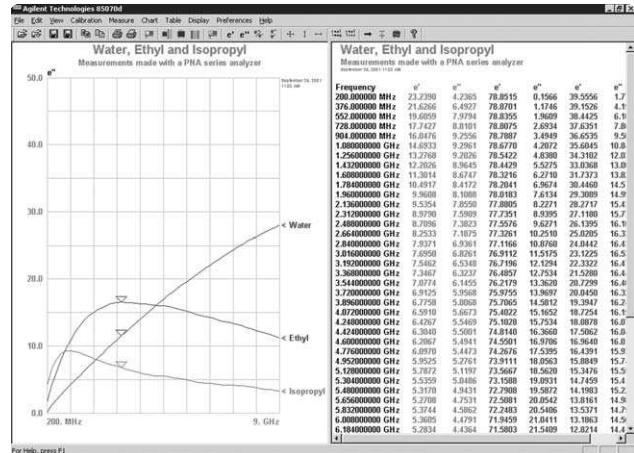

Split screen window and marker aids in data analysis. Simply click on a point on the chart or list to activate the marker.

## Contents of 85070D high-temperature dielectric probe kit

<b>High-temperature dielectric probe</b>	3.5 mm (m) connector type
<b>Dielectric probe software</b>	Windows <sup>®</sup> 95, 98, 2000, Me or Windows NT <sup>®</sup> 4.0 compatible
<b>Flexible cable</b>	Connects probe to network analyzer test port; 1 meter long with SMA (f) to SMA (f) connectors.
<b>High-temperature cable (Option 002)</b>	1 meter long semi-rigid high-temperature ( $-40\text{ }^{\circ}\text{C}$ to $+200\text{ }^{\circ}\text{C}$ ) cable with SMA (f) to SMA (f) connectors.
<b>Adapters</b>	Adapts network analyzer test port to flexible cable, when necessary; includes one 3.5 mm (m) to 7 mm adapter for 7 mm test ports and one 3.5 mm (m) to Type-N (m) adapter for Type-N (f) test ports.
<b>50 <math>\Omega</math> termination</b>	Used for open/short/load calibrations; 3.5 mm (m) connector type.
<b>Shorting block and clamp</b>	Fits over probe face for a repeatable short circuit.
<b>Mounting bracket</b>	Keeps probe in a fixed position to minimize cable movement for more repeatable measurements; bracket fits a 1/2-inch diameter support rod.
<b>Probe stand (Option 001)</b>	Probe stand consists of a 24-inch high, 1/2-inch diameter metal support rod with a 13 x 7-inch porcelain base.
<b>Liquid vials (2) with stoppers and adapter</b>	For measurements of liquids; 15 ml volume.

# Performance characteristics

Specifications describe the warranted performance over the temperature range 0 to 55 °C. Supplemental characteristics are intended to provide information useful in applying the instrument, by giving typical but non-warranted performance parameters. These are denoted as “typical,” “nominal,” or “approximate.”

## Frequency range

Probe: 200 MHz to 20 GHz (nominal)

Maximum limited by MUT properties:  $< \frac{110}{\sqrt{\epsilon_r^*}} \text{ GHz}$

## Temperature

Range: -40 °C to +200 °C

Rate: < 10° C per minute

## Accuracy (typical)

Dielectric constant,  $\epsilon_r'$ :  $\pm 5\%$

Loss tangent,  $\tan \delta$ ,  $\epsilon_r''/\epsilon_r'$ :  $\pm 0.05$

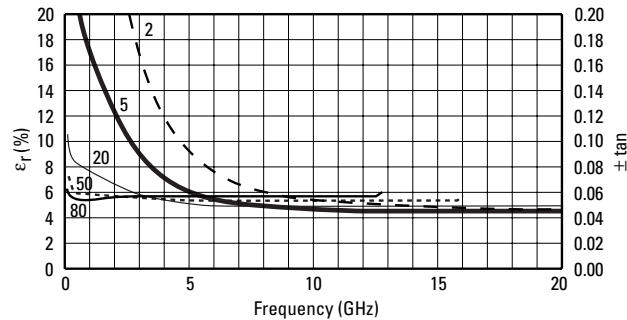

Typical accuracy<sup>1</sup> vs. frequency for  $\epsilon_r^* = 2, 5, 20, 50, 80$

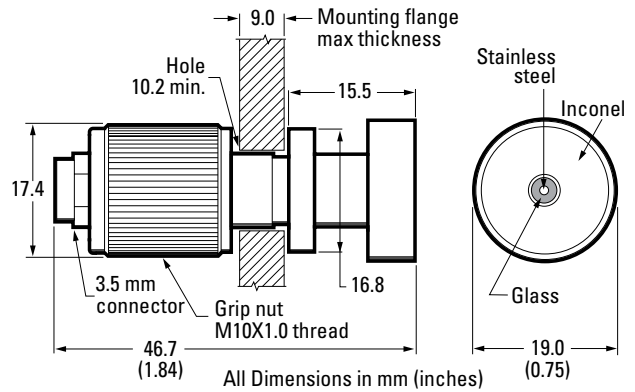

## Repeatability and resolution (typical)

Two to four times better than accuracy.

## Material under test assumptions

Material is “infinite” in size, non-magnetic ( $\mu_r^* = 1$ ), isotropic (uniform orientation), and homogeneous (uniform composition)<sup>2</sup>. Solids have a single, smooth, flat<sup>3</sup> surface with gap-free contact at the probe face.

## Sample requirements

Diameter: > 20 mm

Thickness:  $> \frac{20}{\sqrt{\epsilon_r^*}} \text{ mm}$

Granule size<sup>4</sup>: < 0.3 mm

Maximum recommended  $\epsilon_r'$ : < 100

Minimum recommended  $\tan \delta$ <sup>5</sup>: > 0.05

1. Practical frequency range, accuracy and resolution depend on properties of the MUT. Graphs indicate typical accuracy at 23 ± 3 °C, not including effects of probe contact and cable flexure.
2. If the material is not homogeneous, the result is an average value weighted by the intensity of the E-field which is highest at the center conductor of the probe tip.
3. Sample must be as flat as the probe face which is lapped to ±100 μ inches.
4. Measurement repeatability for granular materials is dependent on density variation.
5. Not recommended for low loss ( $\tan \delta < 0.5$ ) materials with  $\epsilon_r' > 5$ .

# Software menu items

## File

Save or recall measurement setups or previous measurement results. Print copies of the measurement results in a tabular or graphical format.

## Edit

Copy the measurement results to the clipboard. Either graph or the tabular listing can be copied. This allows your measurement results to be pasted into other applications.

## View

Select the section you want to view. Selections include the toolbar, status bar, table of the measurement data and chart of the measurement data.

## Calibration

Select the frequency range, number of points, linear or log sweep. Guided calibration sequence; choice of calibration materials or user-specified; refresh calibration for single standard; recalibration versus temperature.

## Measure

Trigger a measurement.

## Chart

Select the format to be displayed on the chart. Choices include  $\epsilon_r'$ ,  $\epsilon_r''$ ,  $\tan \delta$  and Cole-Cole. Set Graticule scale factors or "autoscale". Select from linear, semi-log or log-log representations.

## Table

Choose between a tabular formatting of real and imaginary or real and  $\tan \delta$ .

## Display

Display current measurement data; save/display up to 3 memory traces; compare data to reference trace with trace math. Turn the marker on or off.

## Preferences

Select your preference of fonts, colors and annotations used to plot and list the measurement data.

## Help

On-line help including the product manual.

## ToolBar

Provides single click access to the most important menu items.

## Ordering information

**85070D** High-temperature dielectric probe kit: Kit includes probe, compatible software, cable, adapters, termination, shorting block, probe bracket, remote trigger and vials. Not included, but required is a PC, and network analyzer.

**Option 001** Adds probe stand (highly recommended)

**Option 002** Adds high temperature cable

**Option 070** Upgrade from any older version of 85070 software.

### Additional available parts

8710-2036 High temperature dielectric probe

1810-0118 50 ohm SMA male termination

85070-60003 Shorting block and clamp

### Free trial demo

Evaluate a demo version of 85070D Dielectric Measurement Software for up to four weeks.

Visit Agilent Technologies website at

**[www.agilent.com/find/materials](http://www.agilent.com/find/materials)**

to download this demo program to your PC.

## Compatible network analyzers

### PNA Series network analyzers:

2 port, 4 receivers	
E8356A	300 kHz to 3 GHz
E8357A	300 kHz to 6 GHz
E8358A	300 kHz to 9 GHz
E8364A	45 MHz to 50 GHz
2 port, 3 receivers	
E8801A	300 kHz to 3 GHz
E8802A	300 kHz to 6 GHz
E8803A	300 kHz to 6 GHz
3 port, 4 receivers	
N3381A	300 kHz to 3 GHz
N3382A	300 kHz to 6 GHz
N3383A	300 kHz to 9 GHz

### Other network analyzers:

8752C	300 kHz to 6 GHz
8753D/E/ET/ES	30 kHz to 6 GHz
8719D/ET/ES	50 MHz to 13.5 GHz
8720D/ET/ES	50 MHz to 20 GHz
8722D/ET/ES	50 MHz to 40 GHz
8712C/ET/ES	300 kHz to 1.3 GHz
8714C/ET/ES	300 kHz to 3 GHz
8510C	45 MHz to 110 GHz

## PC requirements\*

- Windows® 95, 98, 2000, Me or Windows NT® 4.0
- GPIB interface card with a compatible driver (Agilent SICL or National Instruments 488.2M)
- CD drive

\* Note, the 85070D can be installed and run on a PNA Series network analyzer, eliminating the need for both a PC and a GPIB card. To install the 85070D on a PNA analyzer a PC with a CD drive is required to copy the 85070D installation files from the supplied CD to 3.5-inch disks.

 **Agilent Email Updates**

[www.agilent.com/find/emailupdates](http://www.agilent.com/find/emailupdates)

Get the latest information on the products and applications you select.

 **Agilent Direct**

[www.agilent.com/find/agilentdirect](http://www.agilent.com/find/agilentdirect)

Quickly choose and use your test equipment solutions with confidence.

**Agilent  
Open** 

[www.agilent.com/find/open](http://www.agilent.com/find/open)

Agilent Open simplifies the process of connecting and programming test systems to help engineers design, validate and manufacture electronic products. Agilent offers open connectivity for a broad range of system-ready instruments, open industry software, PC-standard I/O and global support, which are combined to more easily integrate test system development.

**www.agilent.com****Agilent Technologies' Test and Measurement Support, Services, and Assistance**

Agilent Technologies aims to maximize the value you receive, while minimizing your risk and problems. We strive to ensure that you get the test and measurement capabilities you paid for and obtain the support you need. Our extensive support resources and services can help you choose the right Agilent products for your applications and apply them successfully. Every instrument and system we sell has a global warranty. Two concepts underlie Agilent's overall support policy: "Our Promise" and "Your Advantage."

**Our Promise**

Our Promise means your Agilent test and measurement equipment will meet its advertised performance and functionality. When you are choosing new equipment, we will help you with product information, including realistic performance specifications and practical recommendations from experienced test engineers. When you receive your new Agilent equipment, we can help verify that it works properly and help with initial product operation.

**Your Advantage**

Your Advantage means that Agilent offers a wide range of additional expert test and measurement services, which you can purchase according to your unique technical and business needs. Solve problems efficiently and gain a competitive edge by contracting with us for calibration, extra-cost upgrades, out-of-warranty repairs, and onsite education and training, as well as design, system integration, project management, and other professional engineering services. Experienced Agilent engineers and technicians worldwide can help you maximize your productivity, optimize the return on investment of your Agilent instruments and systems, and obtain dependable measurement accuracy for the life of those products.

**United States:**

(tel) 800 829 4444

(fax) 800 829 4433

**Canada:**

(tel) 877 894 4414

(fax) 800 746 4866

**China:**

(tel) 800 810 0189

(fax) 800 820 2816

**Europe:**

(tel) 31 20 547 2111

**Japan:**

(tel) (81) 426 56 7832

(fax) (81) 426 56 7840

**Korea:**

(tel) (080) 769 0800

(fax) (080) 769 0900

**Latin America:**

(tel) (305) 269 7500

**Taiwan:**

(tel) 0800 047 866

(fax) 0800 286 331

**Other Asia Pacific****Countries:**

(tel) (65) 6375 8100

(fax) (65) 6755 0042

Email: [tm\\_ap@agilent.com](mailto:tm_ap@agilent.com)

Contacts revised: 09/26/05

**For more information on Agilent Technologies' products, applications or services, please contact your local Agilent office. The complete list is available at:**

**[www.agilent.com/find/contactus](http://www.agilent.com/find/contactus)**

Product specifications and descriptions in this document subject to change without notice.

© Agilent Technologies, Inc. 2002, 2006

Printed in USA, July 13, 2006

5968-5330E

Windows® and Windows NT® are U.S. registered trademarks of Microsoft corporation.