

Agilent 11691D/11692D Directional Couplers 2 to 18 GHz

Product Overview

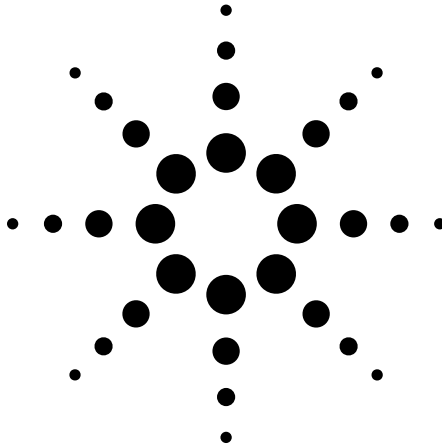

Broadband 20 dB directional couplers

Models 11691D and 11692D high directivity couplers are precision instruments designed for broadband swept reflectometer applications in the 2 to 18 GHz frequency range. With their wide frequency coverage, one of these couplers can replace several couplers without performance degradation, thus adding convenience and economy to swept reflection and transmission coaxial microwave measurements by reducing setup and calibration time. In addition, the broad frequency coverage of the 11691D directional coupler makes it ideal for leveling applications of broadband sources. Its high directivity makes it possible to achieve excellent source matches not achievable with directional detectors.

Specifications

Simultaneous reflection and transmission measurement

These couplers are ideal in reflectometry measurements. The reflection and transmission characteristics of a device can be measured conveniently from 2 to 18 GHz. Figure 1 shows a test configuration in which an 11692D dual coupler and an 11691D single coupler are used to separate and isolate the incident, reflected, and transmitted signals in a swept-frequency measurement of reflection and transmission. These signals are detected and their ratio displayed on a CRT. The 11691D single coupler compensates in the transmitted signal for the coupling variations "seen" by the reference detector.

The compensated ratio (E_{tran}/E_{ref}), being virtually flat, permits high-resolution transmission measurements. These couplers are ideal companions for the 8755 frequency response test set, a 0.1 to 18 GHz detection and display system.

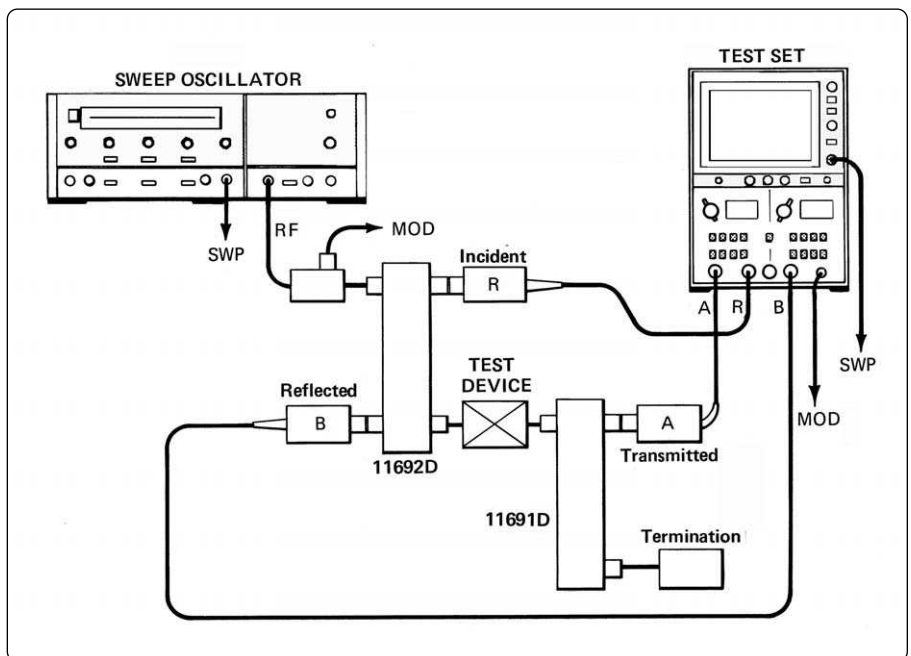

Figure 1. Setup for simultaneous swept measurement of insertion loss (A/R) and return loss (B/R), using 11691D and 11692D couplers.

	11691D	11692D
Frequency range	2 to 18 GHz	2 to 18 GHz
Minimum directivity	2 to 8 GHz: 30 dB	2 to 18 GHz: 30 dB
	8 to 18 GHz: 26 dB ¹	8 to 18 GHz: 26 dB ¹
Maximum primary line SWR	2 to 12.4 GHz: 1.3	2 to 12.4 GHz: 1.3
	12.4 to 18 GHz: 1.40	12.4 to 18 GHz: 1.40
Maximum auxiliary port(s) SWR	1.3	1.3
Nominal coupling (dB)	20	20
Maximum coupling variation with frequency (dB)	±1 dB	±1 dB ²
Tracking auxiliary arms	*	±0.7 dB ^{3*}
Maximum primary line residual loss	< 2 dB	< 1.5 dB
Primary line power	50 W average	50 W average
Handling capability	250 W peak	250 W peak
Net weight	1.93 kg (4 lb, 4 oz)	2.72 kg (6 lb, 0 oz)
Dimensions	404.8 mm (15-15/16 in) L	404.8 mm (15-15/16 in) L
	133.4 mm (5-1/4 in) H	133.4 mm (5-1/4 in) H
	42.9 mm (1-11/16 in)W	42.9 mm (1-11/16 in)W

11691D connector

Option	Primary line Input/output	Auxiliary arms
Standard	APC-7/APC-7	N(f)

11692D connector options

Option	Primary line Input/output	Auxiliary arms Incident/reflection
11692D-005	N(f)/APC-7	N(f)/N(f)
11692D-001	N(f)/N(f)	N(f)/N(f)
11692D-002	N(f)/N(m)	N(f)/N(f)
11692D-003	N(f)/APC-7	APC-7/APC-7
11692D-004	APC-7/APC-7	APC-7/APC-7

Connectors

The APC-7 and type-N connectors are stainless steel designed for durability. The type-N connectors conform to MIL-C-39012 or MIL-C-71.

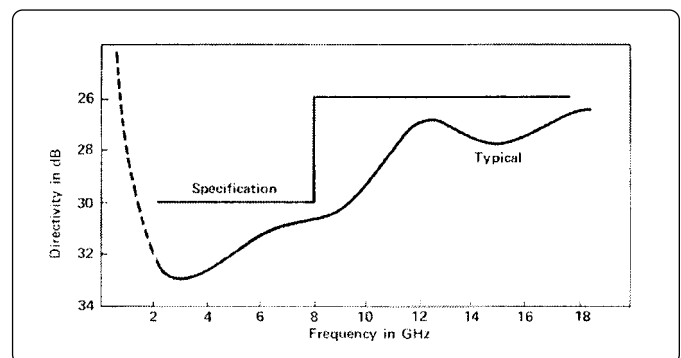

Figure 2. Directivity specifications.

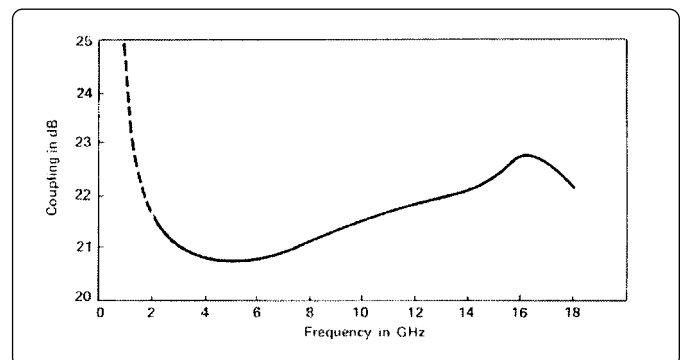

Figure 3. Typical coupling curve.

1. 24 dB with type-N connector on the INPUT PORT (11691D) or TEST PORT (11692D).
 2. Incident to test port.
 3. With the test port shorted and not including source match ripple.
 * Typical tracking between 11691D and 11692D is ±0.07 dB.



Agilent Email Updates

www.agilent.com/find/emailupdates

Get the latest information on the products and applications you select.



Agilent Direct

www.agilent.com/find/agilentdirect

Quickly choose and use your test equipment solutions with confidence.



Agilent Open

www.agilent.com/find/open

Agilent Open simplifies the process of connecting and programming test systems to help engineers design, validate and manufacture electronic products. Agilent offers open connectivity for a broad range of system-ready instruments, open industry software, PC-standard I/O and global support, which are combined to more easily integrate test system development.



is the US registered trademark of the LXI Consortium.

Remove all doubt

Our repair and calibration services will get your equipment back to you, performing like new, when promised. You will get full value out of your Agilent equipment throughout its lifetime. Your equipment will be serviced by Agilent-trained technicians using the latest factory calibration procedures, automated repair diagnostics and genuine parts. You will always have the utmost confidence in your measurements.

Agilent offers a wide range of additional expert test and measurement services for your equipment, including initial start-up assistance onsite education and training, as well as design, system integration, and project management.

For more information on repair and calibration services, go to

www.agilent.com/find/removealldoubt

www.agilent.com

For more information on Agilent Technologies' products, applications or services, please contact your local Agilent office. The complete list is available at:

www.agilent.com/find/contactus

Phone or Fax

United States:

(tel) 800 829 4444

(fax) 800 829 4433

Canada:

(tel) 877 894 4414

(fax) 800 746 4866

China:

(tel) 800 810 0189

(fax) 800 820 2816

Europe:

(tel) 31 20 547 2111

Japan:

(tel) (81) 426 56 7832

(fax) (81) 426 56 7840

Korea:

(tel) (080) 769 0800

(fax) (080)769 0900

Latin America:

(tel) (305) 269 7500

Taiwan:

(tel) 0800 047 866

(fax) 0800 286 331

Other Asia Pacific Countries:

(tel) (65) 6375 8100

(fax) (65) 6755 0042

Email: tm_ap@agilent.com

Contacts revised: 05/21/05

Product specifications and descriptions in this document subject to change without notice.

© Agilent Technologies, Inc. 2001, 2002, 2006

Printed in USA, October 10, 2006

5952-1145



Agilent Technologies