

Agilent HMMC-5025 2-50 GHz Distributed Amplifier

1GG6-8000
Data Sheet

Features

- Frequency Range:
2-50 GHz
- Small Signal Gain:
8.5 dB
- P_{-1 dB} @ 40 GHz: 12 dBm
- Noise Figure:
5 dB @ 2-35 GHz
7 dB @ 35-50 GHz
- Return Loss:
In/Out: <- 10 dB
- 30 dB Gain Control

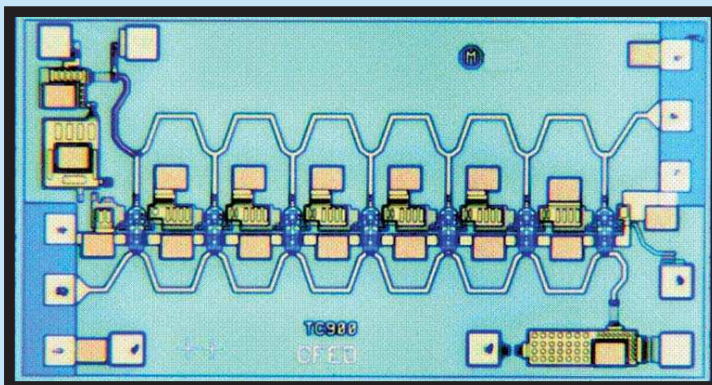

Chip Size: 1720 × 920 μm (67.7 × 36.2 mils)
 Chip Size Tolerance: ±10 μm (±0.4 mils)
 Chip Thickness: 127 ±15 μm (5.0 ±0.6 mils)
 Pad Dimensions: 80 × 80 μm (3.2 × 3.2 mils)

Description

The HMMC-5025 was designed as a generic wide band distributed amplifier, covering the frequency span 2-50 GHz. It consists of seven stages. Each stage is made up of two cascoded FETs with gate peripheries of 48 μm per FET. Both input and output ports were designed to provide 50 Ohm terminations. Bonding pads are provided in the layout to allow amplifier operation at frequencies lower than 2 GHz by means of external circuit components.

The amplifier is biased with a single positive drain supply (V_{DD}) and a single negative gate supply (V_{G1}). A second gate connection is provided for external gain control applications.

Absolute Maximum Ratings¹

Symbol	Parameters/Conditions	Min.	Max.	Units
V _{DD}	Positive Drain Voltage		7.0	volts
I _{DD}	Total Drain Current		170	mA
V _{G1}	First Gate Voltage	-3.5	0	volts
V _{G2}	Second Gate Voltage	-3.0	+3.0	volts
P _{DC Power}	DC Power Dissipation		1.2	watts
P _{in}	CW Input Power		20	dBm
T _{ch}	Operating Channel Temperature		150	°C
T _{case}	Operating Case Temperature	-55		°C
T _{stg}	Storage Temperature	-65	165	°C
T _{max}	Maximum Assembly Temperature (for 60 seconds maximum)		300	°C

¹ Operation in excess of any one of these conditions may result in permanent damage to this device.
 T_A = 25°C except for T_{ch}, T_{stg}, and T_{max}.



Agilent Technologies

DC Specifications/Physical Properties¹

Symbol	Parameters/Conditions	Min.	Typ.	Max.	Units
I_{DSS}	Saturated Drain Current ($V_{DD} = 5.0$ V, $V_{G1} = 0.0$ V, $V_{G2} =$ open circuit)	130	150	170	mA
V_P	First Gate Pinch-Off Voltage ($V_{DD} = 5.0$ V, $I_{DD} = 15$ mA, $V_{G2} =$ open circuit)	-1.7		-0.5	Volts
V_{G2}	Second Gate Self-Bias Voltage ($V_{DD} = 5.0$ V, $I_{DD} = 75$ mA)		2		Volts
$I_{DSOFF}(V_{G1})$	First Gate Pinch-Off Current ($V_{DD} = 5.0$ V, $V_{G1} = -3.5$ V, $V_{G2} =$ open circuit)		6	10	mA
$I_{DSOFF}(V_{G2})$	Second Gate Pinch-Off Current ($V_{DD} = 5.0$ V, $I_{DD} = 75$ mA, $V_{G2} = -2.5$ V)		10		mA
θ_{ch-bs}	Thermal Resistance ($T_{backside} = 25^\circ\text{C}$)		63		$^\circ\text{C}/\text{Watt}$

¹ Measured in wafer form with $T_{chuck} = 25^\circ\text{C}$. (Except θ_{ch-bs})

RF Specifications¹

($V_{DD} = 5.0$ V, $I_{DD}(Q) = 75$ mA, $Z_{in} = Z_o = 50 \Omega$)

Symbol	Parameters/Conditions	2.0-50.0 GHz			Units
		Min.	Typ.	Max.	
BW	Guaranteed Bandwidth ²	2		50	GHz
Gain	Small Signal Gain	7.0	8.5		dB
Δ Gain	Small Signal Gain Flatness		± 0.75	± 1.5	dB
RL_{in}	Input Return Loss	10	15		dB
RL_{out}	Output Return Loss	10	15		dB
Isolation	Reverse Isolation	20	30		dB
$P_{-1\text{ dB}}$	Output Power at 1 dB Gain Compression @ 40 GHz		12		dBm
P_{sat}	Saturated Output Power @ 40 GHz		16		dBm
H_2	Second Harmonic ($2 < f_o < 26$) ($P_o(f_o) = 10$ dBm)		-35		dBc
H_3	Third Harmonic ($2 < f_o < 26$) ($P_o(f_o) = 10$ dBm)		-25		dBc
NF	Noise Figure (2-35 GHz)		5.0		dB
NF	Noise Figure (35-50 GHz)		7.0		dB

¹ Small-signal data measured in wafer form with $T_{chuck} = 25^\circ\text{C}$. Harmonic data measured on individual device mounted in a microcircuit package @ $T_A = 25^\circ\text{C}$.

² Performance may be extended to lower frequencies through the use of appropriate off-chip circuitry.

Applications

The HMMC-5025 traveling wave amplifier is designed for use as a general purpose wideband power stage in communication systems, and microwave instrumentation, and optical systems. It is ideally suited for broadband applications requiring a flat gain response and excellent port matches over a 2 to 50 GHz frequency range. Dynamic gain control and low-frequency extension capabilities are designed into these devices.

It is characteristic of traveling wave amplifiers that S_{22} tends to 0 dB and greater out of band. This is the design trade-off for the broadband performance of TWAs. As a consequence, TWAs are not necessarily unconditionally stable out of band. This means that if a TWA is followed by a reflective low-pass filter, oscillations can occur. This phenomenon is exacerbated by low temperature where the gain is higher. More data will follow on individual devices.

Biasing and Operation

The recommended bias conditions for best performance for the HMMC-5025 are $V_{DD} = 5.0$ V, $I_{DD} = 75$ mA. To achieve these drain current levels, V_{G1} is typically biased between -0.2 V and -0.6 V. No other bias supplies or connections to the device are required for 2 to 50 GHz operation. The gate voltage (V_{G1}) should be applied prior to the drain voltage (V_{DD}) during power up and removed after the drain voltage during power down.

The HMMC-5025 is a DC coupled amplifier. External coupling capacitors are needed on RF_{IN} and RF_{OUT} ports. The drain bias pad is connected to RF and must be decoupled to the lowest operating frequency.

The auxiliary gate and drain contacts are provided when performance below 1 GHz is required. Connect external capacitors to ground to maintain

input and output VSWR at low frequencies (see Additional References). Do not apply bias to these pads.

The second gate (V_{G2}) can be used to obtain 30 dB (typical) dynamic gain control. For normal operation, no external bias is required on this contact.

Assembly Techniques

GaAs MMICs are ESD sensitive. ESD preventive measures must be employed in all aspects of storage, handling, and assembly.

MMIC ESD precautions, handling considerations, die attach and bonding methods are critical factors in successful GaAs MMIC performance and reliability.

Agilent application note #54, "GaAs MMIC ESD, Die Attach and Bonding Guidelines" provides basic information on these subjects.

Additional References:

AN #56, "GaAs MMIC TWA Users Guide."

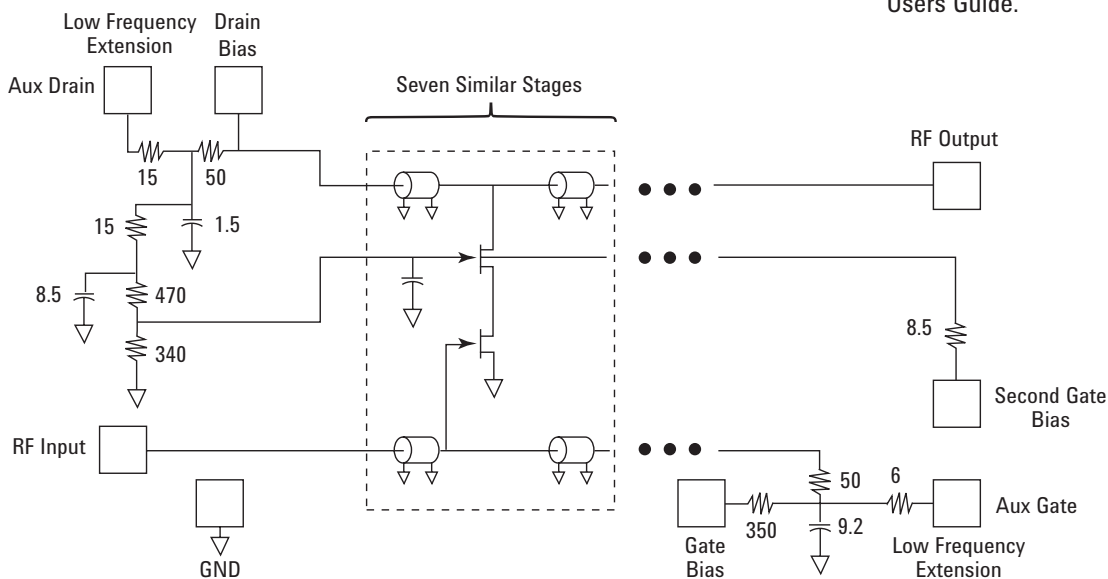

Figure 1. Schematic

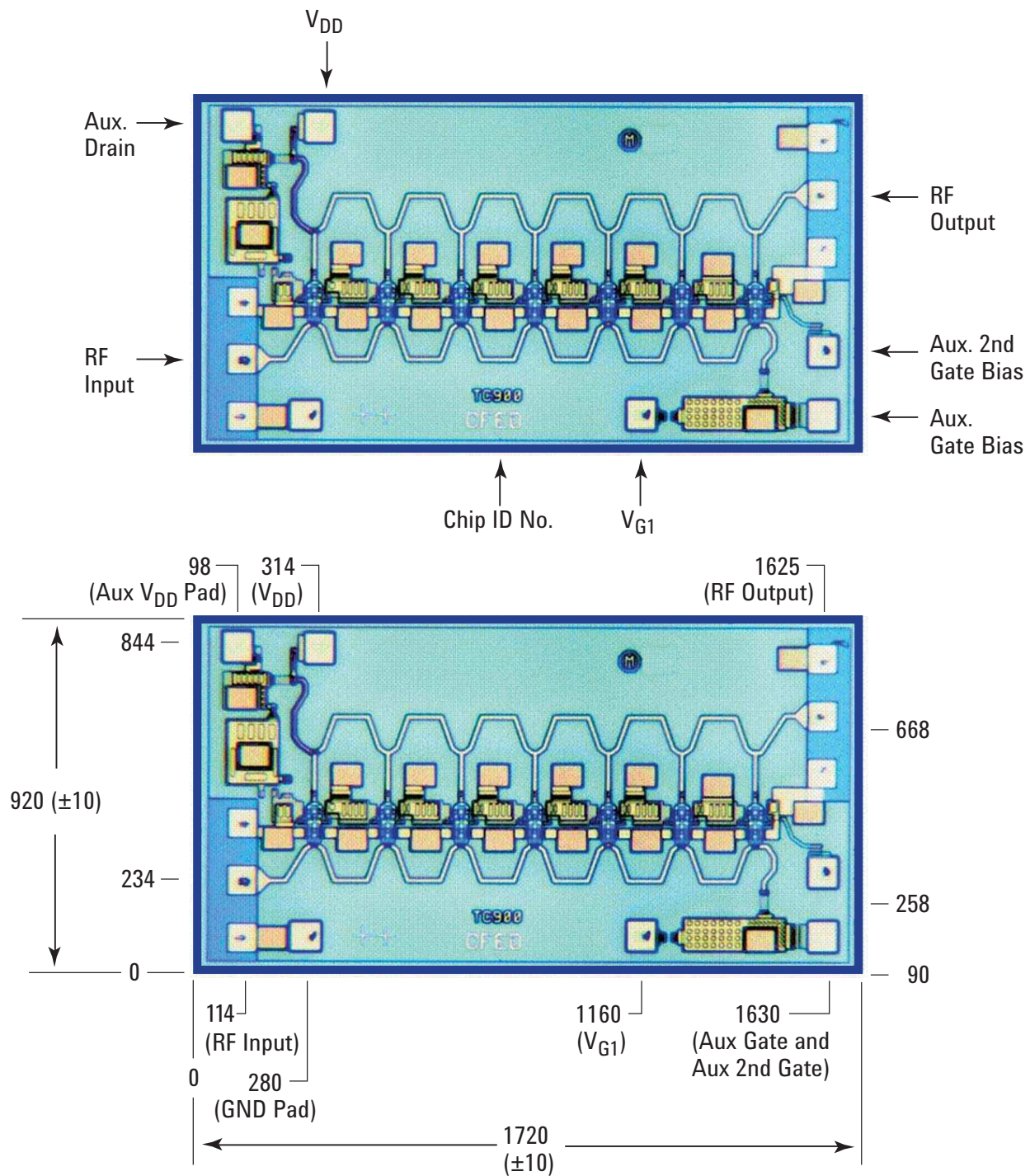

Figure 2. Bond Pad Locations

Drain bias must be decoupled from RF to lowest operating frequency. (AN #56).

4 nH inductor for operation to 2 GHz (200 mil bond wire).

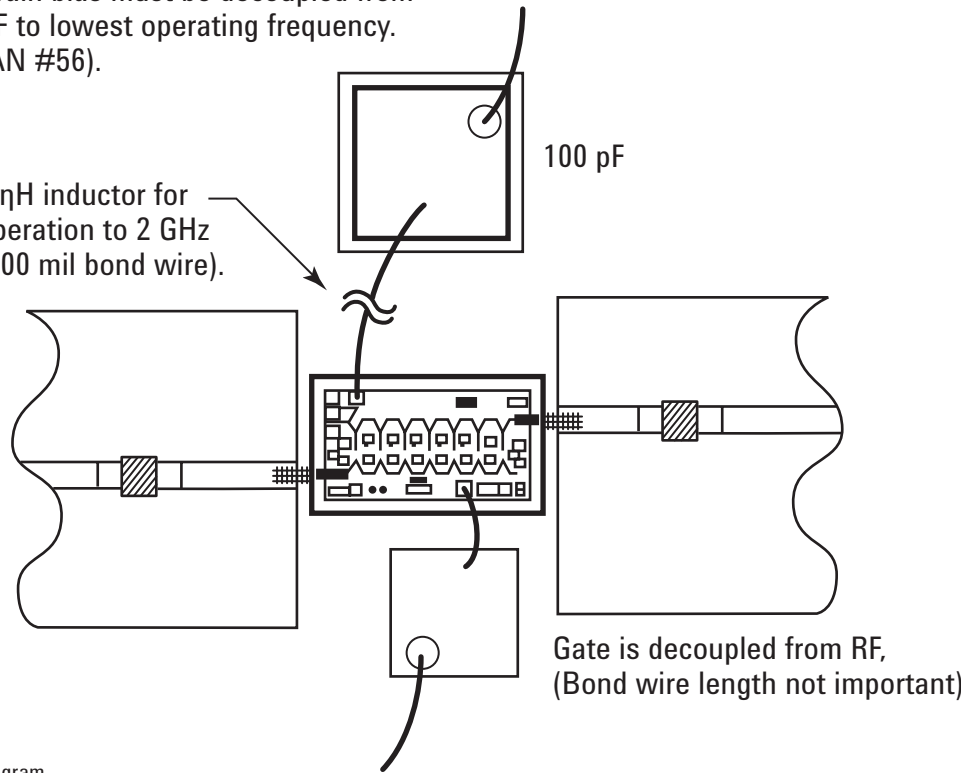

Figure 3. Assembly Diagram

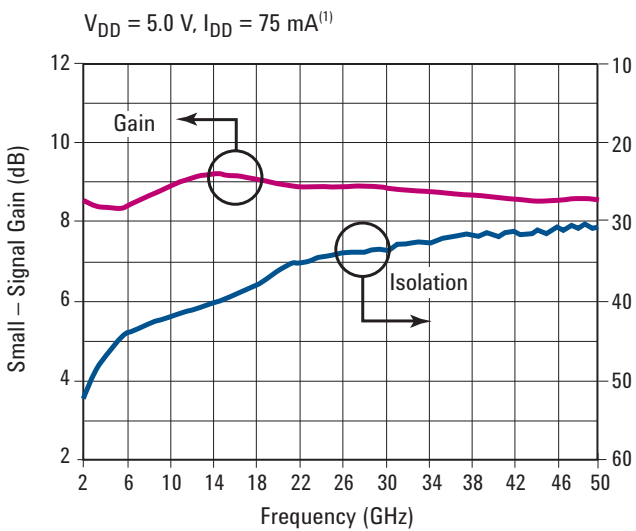

Figure 4. Typical Gain and Reverse Isolation vs. Frequency

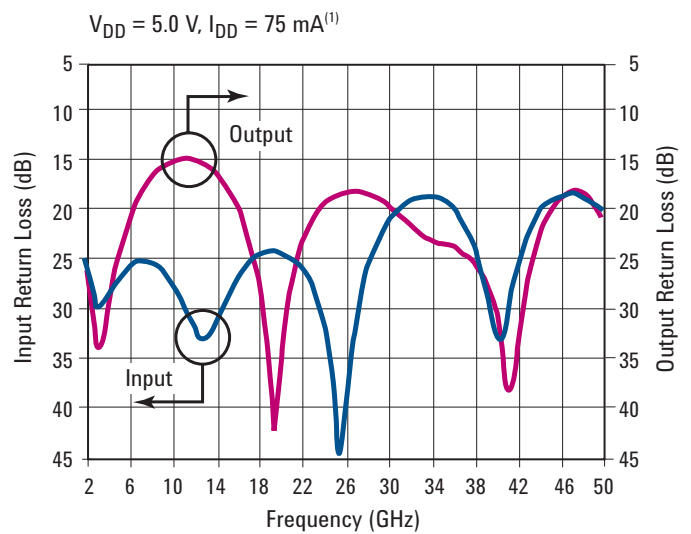

Figure 5. Typical Input and Output Return Loss vs. Frequency

¹ Data obtained from on-wafer measurements. $T_{\text{chuck}} = 25^\circ\text{C}$.

Typical S-Parameters¹

(T_{chuck} = 25°C, V_{DD} = 5.0 V, I_{DD} = 75 mA, Z_{in} = Z_o = 50 Ω)

Freq. (GHz)	S ₁₁			S ₁₂			S ₂₁			S ₂₂		
	dB	Mag	Ang	dB	Mag	Ang	dB	Mag	Ang	dB	Mag	Ang
2	-24.6	0.059	-150.2	-52.0	0.0025	-110.2	8.5	2.660	147.8	-26.1	0.049	-64.0
3	-29.7	0.033	147.5	-49.1	0.0035	-130.2	8.4	2.630	139.6	-33.8	0.020	-23.6
4	-28.9	0.036	89.0	-47.1	0.0044	-146.4	8.4	2.630	129.8	-30.1	0.031	43.9
5	-27.0	0.045	56.2	-45.5	0.0053	-161.6	8.4	2.629	119.5	-24.6	0.059	55.9
6	-25.8	0.052	32.6	-44.2	0.0061	-176.8	8.4	2.643	108.9	-20.8	0.091	52.1
7	-25.2	0.055	12.7	-43.3	0.0068	169.3	8.5	2.668	98.1	-18.4	0.121	43.8
8	-25.4	0.054	-6.3	-42.6	0.0074	155.6	8.6	2.705	86.9	-16.7	0.147	33.4
9	-26.0	0.050	-25.3	-42.1	0.0078	143.8	8.8	2.743	75.5	-15.6	0.166	22.3
10	-27.4	0.043	-46.3	-41.7	0.0083	132.1	8.9	2.787	63.7	-15.0	0.178	10.7
11	-29.4	0.034	-70.4	-41.4	0.0085	121.9	9.0	2.823	51.6	-14.8	0.182	-0.9
12	-31.7	0.026	-102.9	-40.9	0.0090	112.3	9.1	2.853	39.3	-14.9	0.179	-12.6
13	-33.0	0.022	-145.8	-40.7	0.0093	104.5	9.2	2.874	26.9	-15.4	0.169	-24.2
14	-31.4	0.027	168.6	-40.3	0.0097	95.4	9.2	2.891	14.3	-16.3	0.153	-35.7
15	-29.1	0.035	136.8	-39.7	0.0104	88.5	9.2	2.891	1.8	-17.6	0.131	-47.3
16	-27.0	0.045	113.4	-39.0	0.0112	80.5	9.2	2.884	-10.8	-19.5	0.106	-59.3
17	-25.4	0.053	95.4	-38.4	0.0120	71.9	9.2	2.870	-23.3	-22.2	0.077	-72.0
18	-24.5	0.060	77.9	-37.7	0.0131	62.9	9.1	2.853	-35.7	-26.7	0.046	-86.1
19	-24.1	0.062	62.1	-37.1	0.0140	53.8	9.1	2.836	-48.1	-35.6	0.017	-114.9
20	-24.4	0.061	48.2	-36.3	0.0153	44.3	9.0	2.819	-60.3	-35.3	0.017	107.2
21	-25.0	0.056	37.0	-35.3	0.0172	32.7	9.0	2.806	-72.6	-27.0	0.045	80.0
22	-25.6	0.052	22.6	-35.1	0.0176	19.5	8.9	2.798	-84.7	-23.2	0.069	66.2
23	-27.7	0.041	7.2	-34.7	0.0184	8.9	8.9	2.796	-97.1	-21.0	0.089	54.9
24	-30.9	0.028	-8.2	-34.4	0.0191	-2.8	8.9	2.789	-109.5	-19.4	0.107	44.2
25	-38.4	0.012	-39.5	-34.3	0.0194	-14.7	8.9	2.789	-121.9	-18.6	0.118	33.6
26	-40.1	0.010	-169.3	-33.9	0.0202	-25.3	8.9	2.789	-134.5	-18.2	0.124	24.2
27	-30.9	0.029	156.0	-33.7	0.0206	-37.0	8.9	2.794	-147.2	-18.2	0.124	15.5
28	-26.0	0.050	138.6	-33.7	0.0206	-48.5	8.9	2.795	-160.1	-18.4	0.120	7.7
29	-23.1	0.070	122.8	-33.4	0.0213	-58.3	8.9	2.787	-173.1	-18.8	0.115	2.1
30	-21.0	0.089	110.2	-33.3	0.0216	-71.3	8.9	2.780	174.0	-19.6	0.105	-3.4
31	-19.8	0.102	95.3	-32.9	0.0228	-81.1	8.9	2.772	160.9	-20.5	0.095	-7.5
32	-18.9	0.114	82.3	-32.5	0.0236	-93.6	8.8	2.768	147.8	-21.3	0.086	-9.1
33	-18.6	0.117	70.4	-32.3	0.0244	-105.4	8.8	2.762	134.5	-22.4	0.076	-6.4
34	-18.5	0.118	58.6	-32.3	0.0244	-120.3	8.8	2.752	121.2	-23.0	0.071	-4.7
35	-19.0	0.112	46.2	-31.9	0.0254	-132.8	8.8	2.747	107.8	-23.5	0.067	-3.5
36	-20.0	0.100	35.6	-31.6	0.0264	-146.2	8.8	2.741	94.4	-23.7	0.066	-2.5
37	-21.5	0.084	26.4	-31.5	0.0266	-161.5	8.7	2.735	80.7	-24.4	0.060	-4.3
38	-24.0	0.063	18.8	-31.5	0.0267	-175.1	8.7	2.728	67.0	-25.4	0.054	-8.9
39	-27.6	0.042	18.9	-31.5	0.0266	171.1	8.7	2.723	53.0	-27.1	0.044	-11.8
40	-32.9	0.023	46.7	-31.4	0.0270	157.6	8.7	2.711	39.0	-30.4	0.030	-9.1
41	-30.3	0.031	99.2	-31.2	0.0276	140.9	8.6	2.703	24.8	-38.1	0.012	18.9
42	-25.5	0.053	107.1	-31.0	0.0282	125.0	8.6	2.695	10.5	-32.6	0.023	93.1
43	-22.2	0.078	102.7	-31.4	0.0270	115.6	8.6	2.689	-4.0	-26.2	0.049	94.9
44	-20.1	0.099	94.4	-31.1	0.0280	101.4	8.6	2.679	-18.1	-22.4	0.076	86.4
45	-19.0	0.112	85.3	-31.3	0.0272	87.2	8.5	2.672	-33.4	-20.2	0.098	75.3
46	-18.6	0.117	76.5	-30.5	0.0297	72.1	8.5	2.676	-48.5	-18.8	0.115	61.6
47	-18.3	0.121	69.8	-30.6	0.0297	49.9	8.6	2.686	-64.0	-18.0	0.126	48.2
48	-18.8	0.115	62.5	-30.7	0.0293	37.8	8.6	2.689	-79.8	-18.3	0.122	28.8
49	-19.3	0.108	59.9	-30.5	0.0300	20.0	8.6	2.691	-96.1	-19.5	0.106	6.1
50	-20.3	0.096	58.9	-30.3	0.0307	2.7	8.6	2.677	-293.0	-21.7	0.082	-22.7

¹ Data obtained from on-wafer measurements.

Additional Performance Characteristics

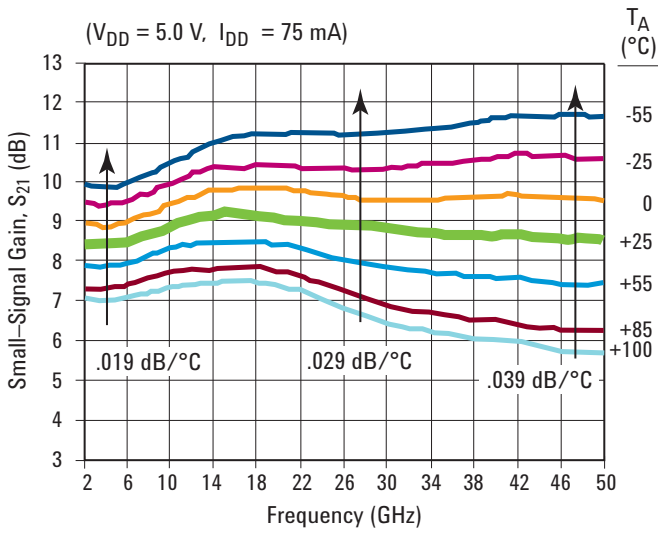

Figure 6. Typical Small-Signal Gain vs. Temperature

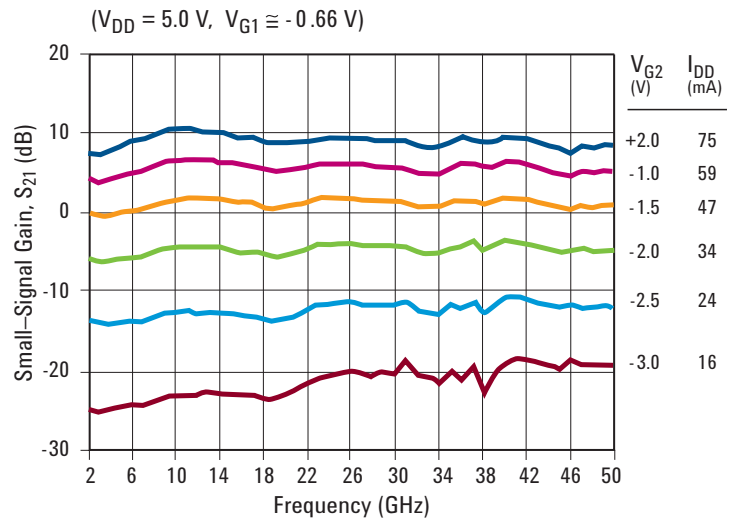

Figure 7. Typical Gain vs. Second Gate Control Voltage

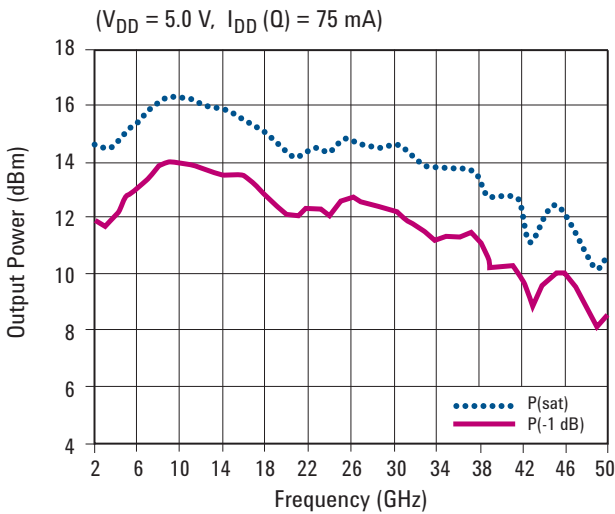

Figure 8. Typical 1 dB Gain Compression and Saturated Output Power vs. Frequency

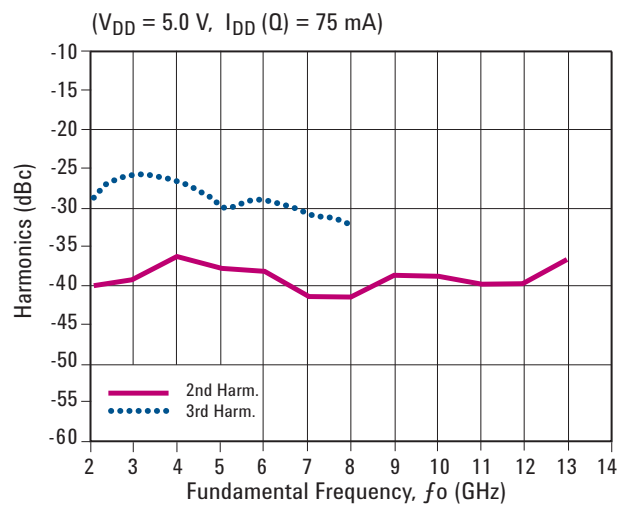

Figure 9. Typical Second and Third Harmonics vs. Fundamental Frequency at $P_{out} = 10$ dBm

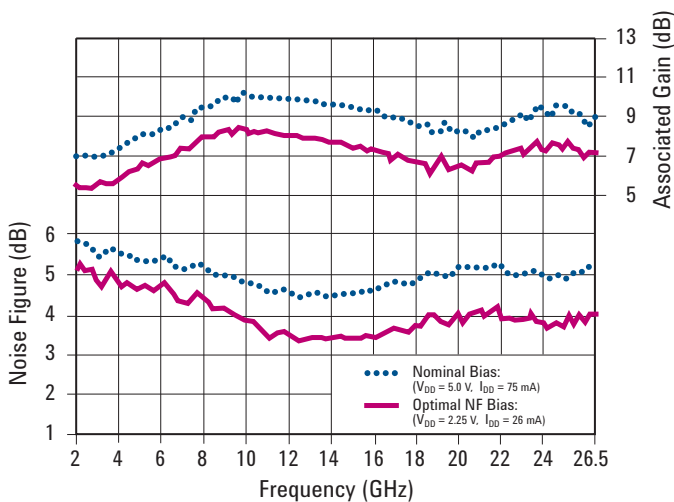

Figure 10. Typical Noise Figure Performance vs. Frequency.

Notes:

All data measured on individual devices mounted in a 50 GHz test package $T_A = 25^\circ\text{C}$ (except where noted).

This data sheet contains a variety of *typical* and guaranteed performance data. The information supplied should not be interpreted as a complete list of circuit specifications. Customers considering the use of this, or other TCA GaAs ICs, for their design should obtain the current production specifications from Agilent TCA Marketing. In this data sheet the term *typical* refers to the 50th percentile performance. For additional information contact Agilent TCA Marketing at 707-577-4482.



Agilent Email Updates

www.agilent.com/find/emailupdates

Get the latest information on the products and applications you select.



Agilent Direct

www.agilent.com/find/quick

Quickly choose and use your test equipment solutions with confidence.



www.agilent.com/find/open

Agilent Open simplifies the process of connecting and programming test systems to help engineers design, validate and manufacture electronic products. Agilent offers open connectivity for a broad range of system-ready instruments, open industry software, PC-standard I/O and global support, which are combined to more easily integrate test system development.

LXI is the U.S. registered trademark of the LXI Consortium.

www.agilent.com

For more information on Agilent Technologies' products, applications or services, please contact your local Agilent office. The complete list is available at:

www.agilent.com/find/contactus

Phone or Fax

United States:

(tel) 800 829 4444
(fax) 800 829 4433

Canada:

(tel) 877 894 4414
(fax) 800 746 4866

China:

(tel) 800 810 0189
(fax) 800 820 2816

Europe:

(tel) 31 20 547 2111

Japan:

(tel) (81) 426 56 7832
(fax) (81) 426 56 7840

Korea:

(tel) (080) 769 0800
(fax) (080) 769 0900

Latin America:

(tel) (305) 269 7500

Taiwan:

(tel) 0800 047 866
(fax) 0800 286 331

Other Asia Pacific Countries:

(tel) (65) 6375 8100
(fax) (65) 6755 0042
Email: tm_ap@agilent.com

Revised: 11/08/06

Product specifications and descriptions in this document subject to change without notice.

© Agilent Technologies, Inc. 2007

Printed in USA, March 23, 2007

5989-6207EN



Agilent Technologies