



Agilent HMMC-5021 (2-22 GHz), HMMC-5022 (2-22 GHz), and HMMC-5026 (2-26.5 GHz) GaAs MMIC Traveling Wave Amplifier

1GG7-8000, 1GG7-8006, 1GG7-8007
Data Sheet

Description

The HMMC-5021/22/26 is a broadband GaAs MMIC traveling wave amplifier designed for high gain and moderate output power over the full 2 to 26.5 GHz frequency range. Seven MES-FET cascode stages provide a flat gain response, making the HMMC-5021/22/26 an ideal wideband gain block. Optical lithography is used to produce gate lengths of $\approx 0.4 \mu\text{m}$. The HMMC-5021/22/26 incorporates advanced MBE technology, Ti-Pt-Au gate metallization, silicon nitride passivation, and polyimide for scratch protection.

Features

- Wide-frequency range: 2-26.5 GHz
- High gain: 9.5 dB
- Gain flatness: ± 0.75 dB
- Return loss:
Input: -14 dB, Output: -13 dB
- Low-frequency operation capability:
< 2 GHz
- Gain control: 35 dB dynamic range
- Moderate power:
20 GHz:
 $P_{-1\text{ dB}}$: 18 dBm
 P_{sat} : 20 dBm
 26.5 GHz:
 $P_{-1\text{ dB}}$: 15 dBm
 P_{sat} : 17 dBm

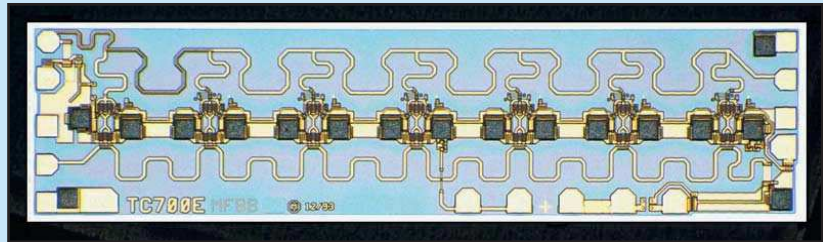

Chip Size: 2980 × 770 μm (117.3 × 30.3 mils)
 Chip Size Tolerance: $\pm 10 \mu\text{m}$ (± 0.4 mils)
 Chip Thickness: 127 \pm 15 μm (5.0 \pm 0.6 mils)
 Pad Dimensions: 75 × 75 μm (2.95 × 2.95 mils), or larger

Absolute Maximum Ratings¹

Symbol	Parameters/Conditions	Min.	Max.	Units
V_{DD}	Positive Drain Voltage		8.0	volts
I_{DD}	Total Drain Current		250	mA
V_{G1}	First Gate Voltage	-5	0	volts
I_{G1}	First Gate Current	-9	+5	mA
V_{G2}^2	Second Gate Voltage	-2.5	+3.5	volts
I_{G2}	Second Gate Current	-7		mA
P_{DC}	DC Power Dissipation		2.0	watts
P_{in}	CW Input Power		23	dBm
T_{ch}	Operating Channel Temp.		+150	$^{\circ}\text{C}$
T_{case}	Operating Case Temp.	-55		$^{\circ}\text{C}$
T_{stg}	Storage Temperature	-65	+165	$^{\circ}\text{C}$
T_{max}	Max. Assembly Temp. (for 60 seconds maximum)		300	$^{\circ}\text{C}$

¹ Operation in excess of any one of these conditions may result in permanent damage to this device.
 $T_{\text{A}} = 25^{\circ}\text{C}$ except for T_{ch} , T_{stg} , and T_{max} .

² Minimum voltage on V_{G2} must not violate the following: $V_{\text{G2}}(\text{min}) > V_{\text{DD}} - 9$ volts.



DC Specifications/Physical Properties¹ (Applies to all part numbers)

Symbol	Parameters/Conditions	Min.	Typ.	Max.	Units
I_{DSS}	Saturated Drain Current ($V_{DD} = 7.0$ V, $V_{G1} = 0.0$ V, $V_{G2} =$ open circuit)	115	180	250	mA
V_p	First Gate Pinch-Off Voltage ($V_{DD} = 7.0$ V, $I_{DD} = 16$ mA, $V_{G2} =$ open circuit)	-3.5	-1.5	-0.5	volts
V_{G2}	Second Gate Self-Bias Voltage ($V_{DD} = 7.0$ V, $V_{G1} = 0.0$ V)		2.1		volts
I_{DSOFF} (V_{G1})	First Gate Pinch-Off Current ($V_{DD} = 7.0$ V, $V_{G1} = -3.5$ V, $V_{G2} =$ open circuit)		4		mA
I_{DSOFF} (V_{G2})	Second Gate Pinch-Off Current ($V_{DD} = 5.0$ V, $V_{G1} = 0.0$ V, $V_{G2} = -3.5$ V)		8		mA
θ_{ch-bs}	Thermal Resistance ($T_{backside} = 25^\circ\text{C}$)		36		$^\circ\text{C}/\text{W}$

¹ Measured in wafer form with $T_{chuck} = 25^\circ\text{C}$. (Except θ_{ch-bs}).

RF Specifications

($V_{DD} = 7.0$ V, $I_{DD}(Q) = 150$ mA, $Z_{in} = Z_o = 50 \Omega$)¹

Symbol	Parameters/Conditions	2.0-22.0 GHz				2.0-26.5 GHz				Units		
		Typ.	HMMC-5022		Typ.	HMMC-5026		Units				
			Min.	Max.		Min.	Max.		Min.		Max.	
BW	Guaranteed Bandwidth ²		2	22	2	22	2	24	26.5	2	26.5	GHz
S_{21}	Small Signal Gain	10			8	12	9.5	7	12	8	12	dB
ΔS_{21}	Small Signal Gain Flatness	± 0.5				± 1	± 0.75		± 1.5		± 1	dB
$RL_{in(min)}$	Minimum Input Return Loss	16			15		14	12			12	dB
$RL_{out(min)}$	Minimum Output Return Loss	13			13		13	10			12	dB
Isolation	Minimum Reverse Isolation	32			23		30	23			25	dB
$P_{-1\text{ dB}}$	Output Power at 1 dB Gain Compression	18			15		15	12			12	dBm
P_{sat}	Saturated Output Power	20			17		17	14	18		14	dBm
$H_{2(max)}$	Max. Second Harm. ($2 < f_o < 20$), [$P_o(f_o) = 17$ dBm or $P_{-1\text{ dB}}$, whichever is less]	-25			-20		-25				-20	dBc
$H_{3(max)}$	Max. Third Harm. ($2 < f_o < 20$), [$P_o(f_o) = 17$ dBm or $P_{-1\text{ dB}}$, whichever is less]	-34			-20		-34				-20	dBc
NF	Noise Figure	8					10					dB

¹ Small-signal data measured in wafer form with $T_{chuck} = 25^\circ\text{C}$. Large-signal data measured on individual devices mounted in an Agilent 83040 Series Modular Microcircuit Package @ $T_A = 25^\circ\text{C}$.

² Performance may be extended to lower frequencies through the use of appropriate off-chip circuitry. Upper -3 dB corner frequency ~ 29.5 GHz.

Applications

The HMMC-5021/22/26 series of traveling wave amplifiers are designed for use as general purpose wideband gain blocks in communication systems and microwave instrumentation. They are ideally suited for broadband applications requiring a flat gain response and excellent port matches over a 2 to 26.5 GHz frequency range. Dynamic gain control and low-frequency extension capabilities are designed into these devices.

It is characteristic of traveling wave amplifiers that S_{22} tends to 0 dB and greater out of band. This is the design trade-off for the broadband performance of TWAs. As a consequence, TWAs are not necessarily unconditionally stable out of band. This means that if a TWA is followed by a reflective low-pass filter, oscillations can occur. This phenomenon is exacerbated by low temperature where the gain is higher. More data will follow on individual devices.

Biasing and Operation

These amplifiers are biased with a single positive drain supply (V_{DD}) and a single negative gate supply (V_{G1}). The recommended bias conditions for the HMMC-5021/22/26 are $V_{DD} = 7.0$ V, $I_{DD} = 150$ mA for best overall performance. To achieve this drain current level, V_{G1} is typically biased between -0.2 V and -0.5 V. No other bias supplies or connections to the device are required for 2 to 26.5 GHz operation. See Figure 3 for assembly information.

The auxiliary gate and drain contacts are used only for low-frequency performance extension below ≈ 1.0 GHz. When used, these contacts must be AC coupled only. (Do not attempt to apply bias to these pads.)

The second gate (V_{G2}) can be used to obtain 35 dB (typical) dynamic gain control.

For normal operation, no external bias is required on this contact and its self-bias voltage is $\approx +2.1$ V. Applying an external bias between its open-circuit voltage and -2.5 volts will adjust the gain while maintaining a good input/output port match.

Assembly Techniques

Solder die-attach using a fluxless AuSu solder preform is the recommended assembly method. Gold thermosonic wedge bonding with 0.7 mil diameter Au wire is recommended for all bonds. Tool force should be 22 ± 1 gram, stage temperature should be $150 \pm 2^\circ\text{C}$, and ultrasonic power and duration should be 64 ± 1 dB and 76 ± 8 msec, respectively. The bonding pad and chip backside metallization is gold.

GaAs MMICs are ESD sensitive. ESD preventive measures must be employed in all aspects of storage, handling, and assembly.

MMIC ESD precautions, handling considerations, die attach and bonding methods are critical factors in successful GaAs MMIC performance and reliability.

Agilent application note #54, "GaAs MMIC ESD, Die Attach and Bonding Guidelines" provides basic information on these subjects.

Additional References:

AN# 31, "2–26.5 GHz Variable Gain Amplifier Using and GaAs MMIC Components," AN# 34, "TWA Environmental Data," AN# 41, "S-Parameters Performance as a Function of Bonding Configuration," and AN# 56, "GaAs MMIC TWA Users Guide."

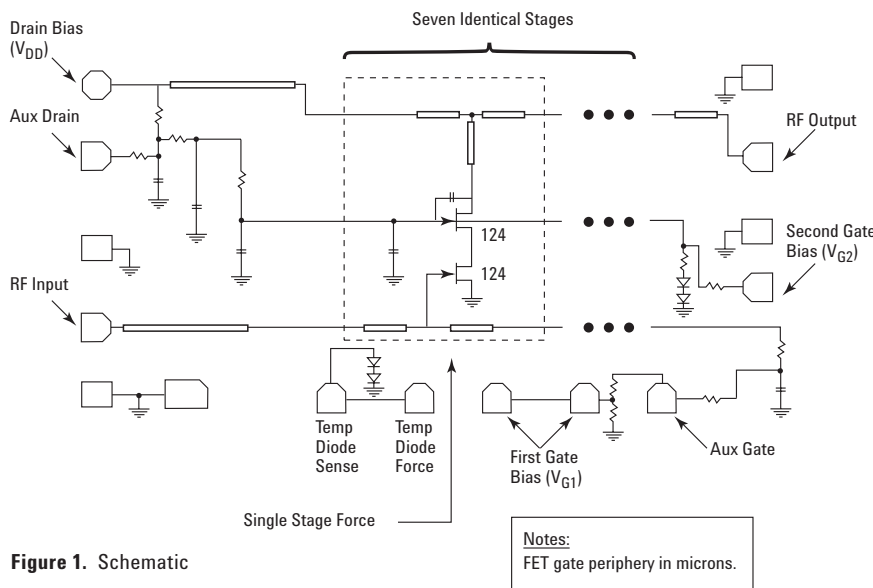

Figure 1. Schematic

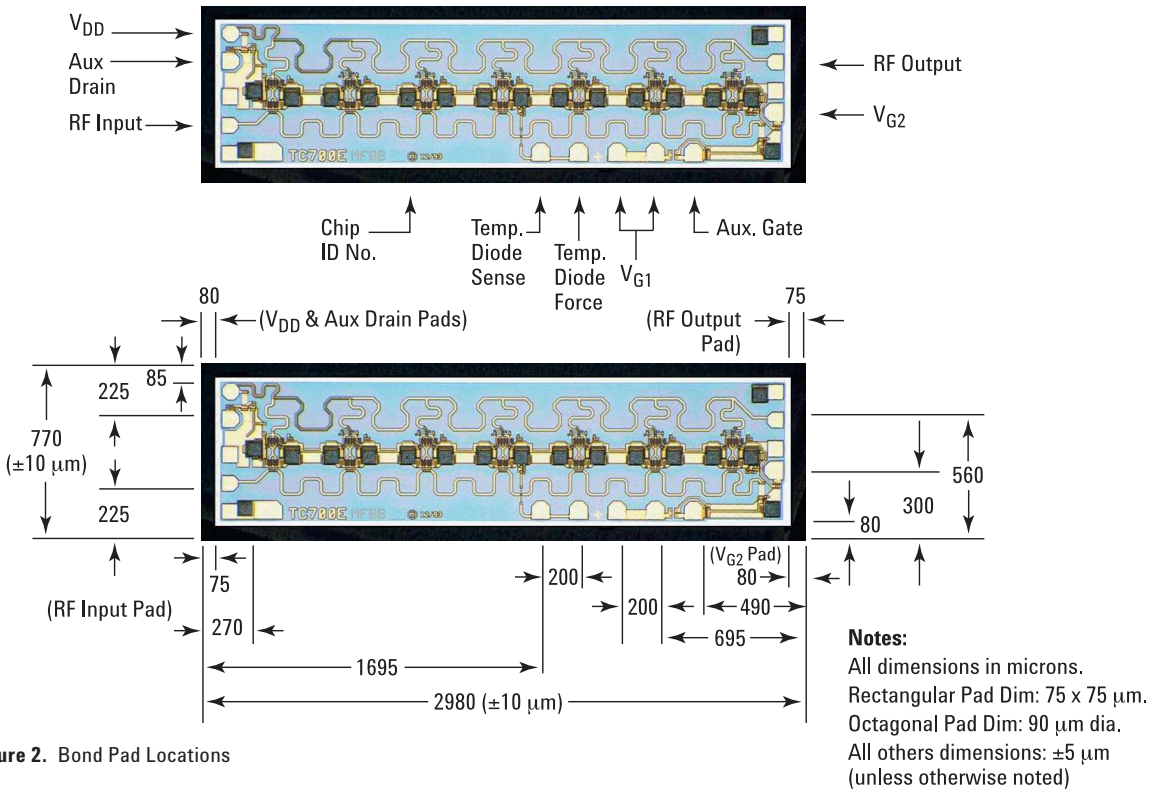

Figure 2. Bond Pad Locations

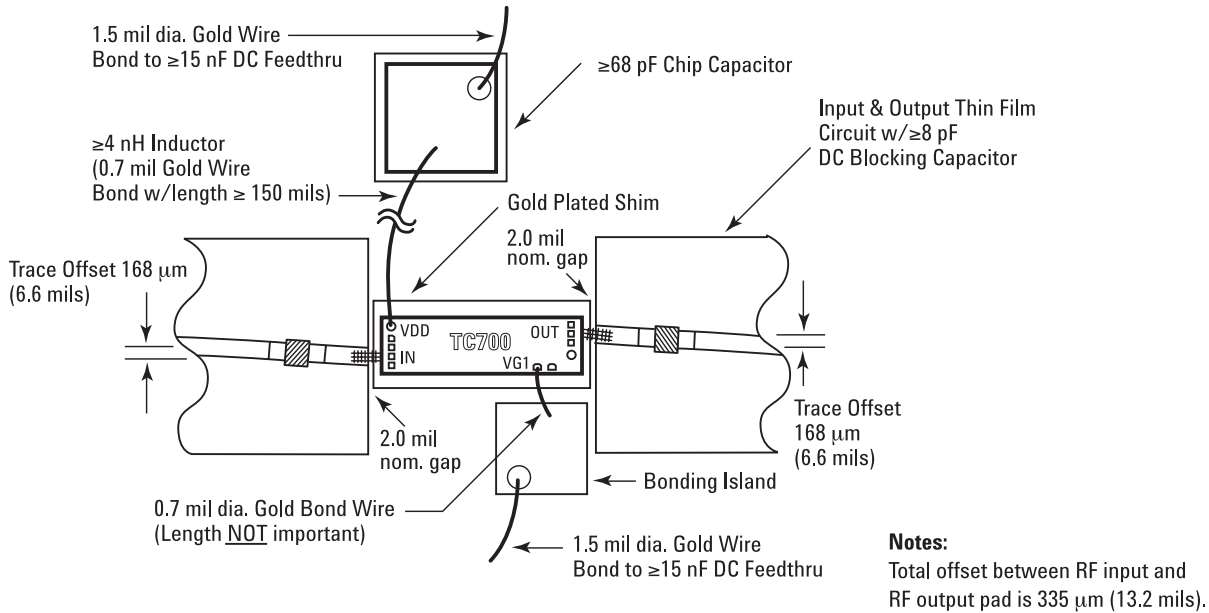

Figure 3. Assembly Diagram (For 2.0–26.5 GHz Operation)

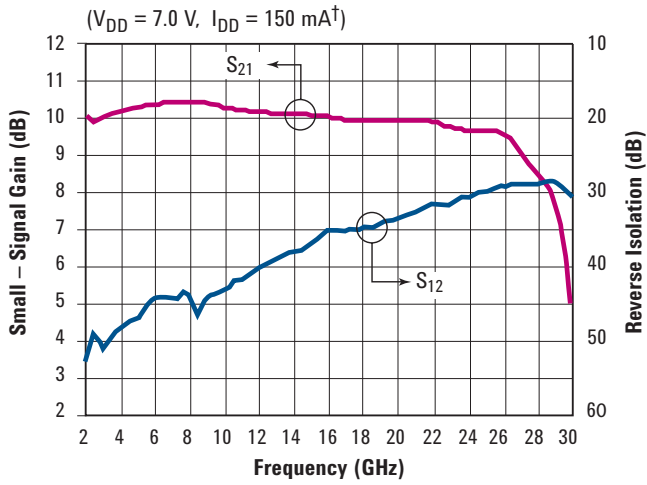

Figure 4. Typical Gain and Reverse Isolation vs. Frequency

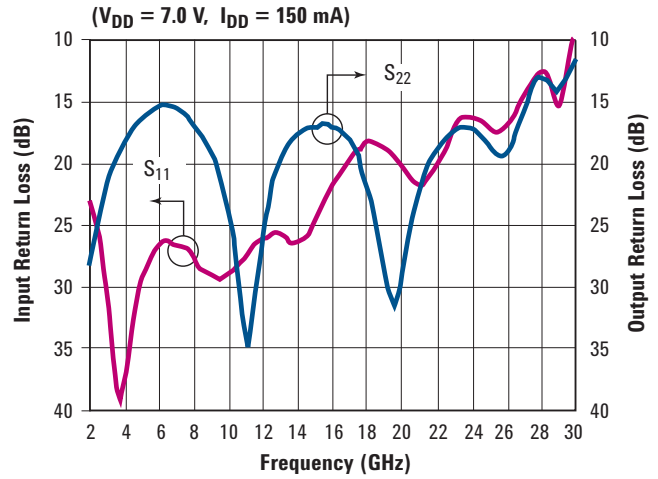

Figure 5. Typical Input and Out Return Loss vs. Frequency

Typical S-Parameters¹

(T_{chuck} = 25°C, V_{DD} = 7.0 V, I_{DD} = 150 mA, Z_{in} = Z_{out} = 50 Ω)

Freq. (GHz)	S ₁₁			S ₁₂			S ₂₁			S ₂₂		
	dB	Mag	Ang	dB	Mag	Ang	dB	Mag	Ang	dB	Mag	Ang
2.0	-22.6	0.074	-174.1	-53.1	0.0022	167.3	-10.1	3.183	123.6	-28.9	0.036	77.3
3.0	-30.6	0.030	130.4	-51.0	0.0028	120.1	-10.0	3.173	102.1	-21.6	0.083	64.1
4.0	-37.8	0.013	-19.8	-48.0	0.0040	95.0	-10.2	3.225	78.2	-18.2	0.124	45.4
5.0	-29.4	0.034	-79.9	-46.8	0.0046	67.1	-10.3	3.275	53.5	-16.3	0.153	23.4
6.0	-26.6	0.047	-113.8	-44.4	0.0060	36.0	-10.4	3.303	28.1	-15.4	0.170	2.5
7.0	-26.6	0.047	-137.0	-44.1	0.0062	1.0	-10.4	3.330	2.3	-15.7	0.165	-19.5
8.0	-27.7	0.041	-152.6	-43.4	0.0067	-27.5	-10.5	3.331	-23.8	-17.0	0.141	-40.7
9.0	-29.0	0.035	-149.8	-44.3	0.0061	-31.8	-10.4	3.312	-50.2	-19.2	0.110	-59.7
10.0	-29.0	0.036	-140.8	-43.0	0.0071	-53.6	-10.3	3.282	-76.4	-24.3	0.061	-76.8
11.0	-27.3	0.043	-138.1	-41.6	0.0083	-74.8	-10.2	3.253	-102.5	-35.1	0.018	-32.6
12.0	-26.2	0.049	-141.9	-40.0	0.0100	-96.9	-10.2	3.227	-128.8	-24.6	0.059	21.0
13.0	-25.8	0.052	-148.5	-38.9	0.0113	-120.9	-10.2	3.218	-155.4	-19.7	0.103	2.8
14.0	-26.4	0.048	-143.0	-38.1	0.0125	-145.6	-10.1	3.204	177.8	-17.6	0.132	-21.2
15.0	-24.6	0.059	-131.7	-36.6	0.0148	-169.9	-10.1	3.197	150.4	-17.0	0.141	-44.8
16.0	-21.6	0.083	-133.7	-35.3	0.0172	160.9	-10.0	3.177	122.5	-17.1	0.140	-67.4
17.0	-19.4	0.107	-143.5	-35.0	0.0177	130.6	-10.0	3.149	94.4	-18.5	0.119	-91.8
18.0	-18.3	0.121	-158.7	-34.7	0.0184	105.0	-9.9	3.138	65.9	-21.8	0.081	-116.0
19.0	-18.7	0.116	-172.6	-33.9	0.0201	80.2	-9.9	3.140	36.8	-28.9	0.036	-121.7
20.0	-20.3	0.097	-179.5	-33.3	0.0217	50.7	-10.0	3.151	6.6	-28.5	0.038	-57.0
21.0	-21.8	0.082	-168.3	-32.7	0.0233	22.5	-10.0	3.150	-24.9	-21.7	0.082	-59.1
22.0	-19.9	0.101	-155.3	-31.7	0.0259	-8.4	-9.9	3.126	-57.5	-18.6	0.117	-81.5
23.0	-17.3	0.137	-158.8	-31.4	0.0268	-39.5	-9.8	3.076	-91.0	-17.3	0.137	-103.3
24.0	-16.3	0.153	-169.9	-30.7	0.0291	-71.5	-9.7	3.045	-125.5	-17.3	0.137	-123.8
25.0	-17.1	0.139	-175.4	-30.0	0.0317	-106.2	-9.7	3.045	-162.2	-18.5	0.118	-135.3
26.0	-17.0	0.141	-165.0	-29.2	0.0345	-145.5	-9.6	3.027	157.2	-19.4	0.107	-122.5
26.5	-15.7	0.163	-161.1	-29.0	0.0356	-166.7	-9.5	2.970	135.4	-17.6	0.132	-114.2
27.0	-14.3	0.192	-162.7	-28.9	0.0357	171.7	-9.2	2.876	112.9	-15.3	0.173	-116.0
28.0	-13.2	0.220	-175.7	-28.8	0.0362	126.3	-8.5	2.648	65.8	-12.6	0.233	-138.1
29.0	-14.1	0.197	-176.9	-28.6	0.0371	73.0	-7.7	2.433	10.3	-15.4	0.170	-144.7
30.0	-11.5	0.266	-171.6	-30.8	0.0287	4.8	-4.6	1.689	-61.1	-8.7	0.369	-123.6

¹ Data obtained from on-wafer measurements.

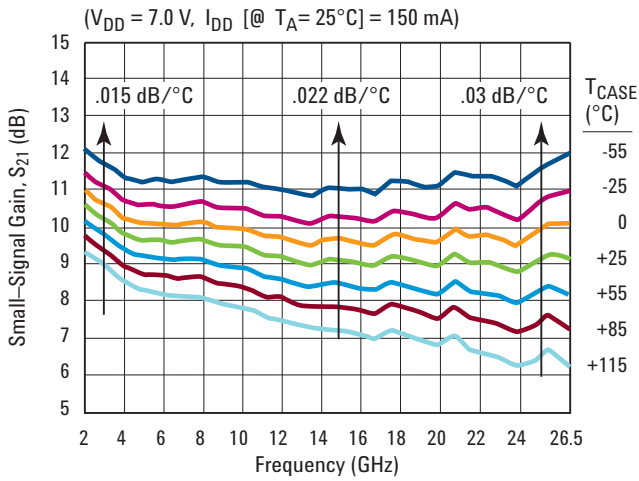

Figure 6. Typical Small-Signal Gain vs. Temperature

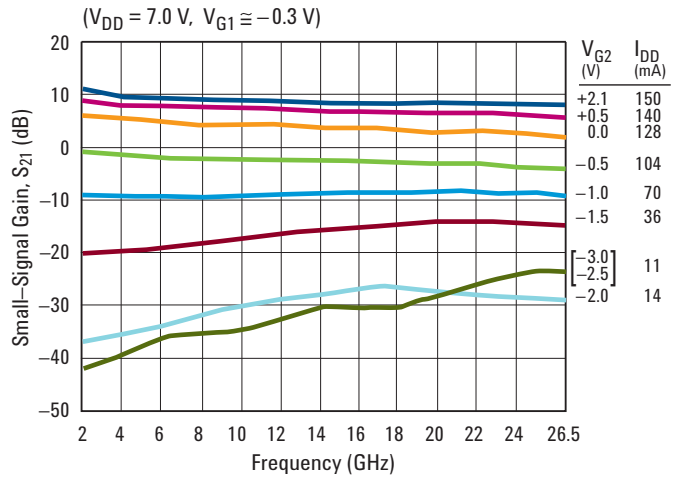

Figure 7. Typical Gain vs. Second Gate Control Voltage

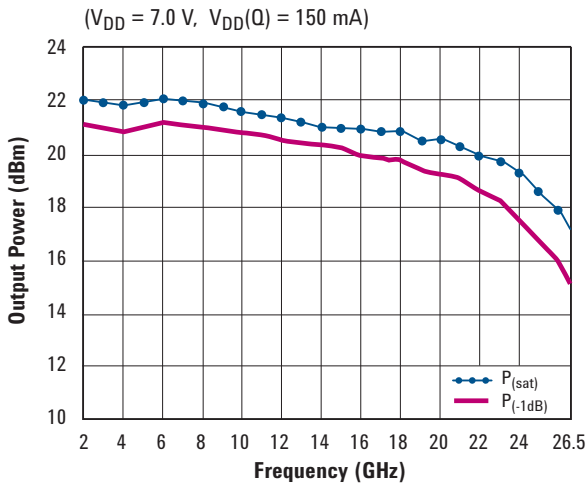

Figure 8. Typical 1 dB Gain Compression and Saturated Output Power

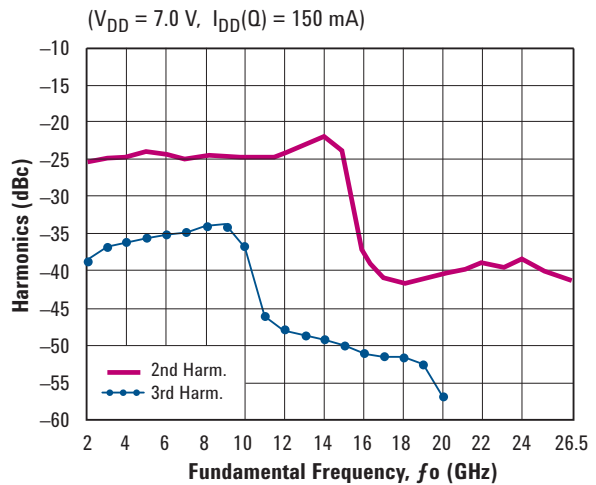

Figure 9. Typical Second and Third Harmonics vs. Fundamental Frequency at P_{out} = +17 dBm

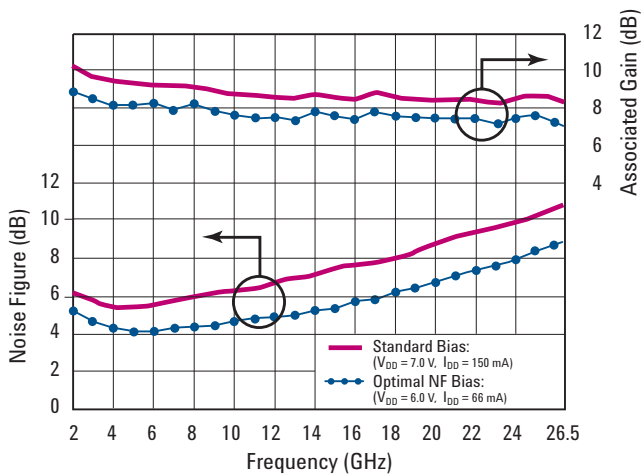

Figure 10. Typical Noise Figure Performance

Notes:

All data measured on individual devices mounted in an Agilent 83040 Series Modular Microcircuit Package @ T_A = 25°C (except where noted).

This data sheet contains a variety of typical and guaranteed performance data. The information supplied should not be interpreted as a complete list of circuit specifications. Customers considering the use of this, or other TCA GaAs ICs, for their design should obtain the current production specifications from Agilent TCA Marketing. In this data sheet the term typical refers to the 50th percentile performance. For additional information contact Agilent TCA Marketing at 707-577-4482.



Agilent Email Updates

www.agilent.com/find/emailupdates

Get the latest information on the products and applications you select.



Agilent Direct

www.agilent.com/find/quick

Quickly choose and use your test equipment solutions with confidence.



www.agilent.com/find/open

Agilent Open simplifies the process of connecting and programming test systems to help engineers design, validate and manufacture electronic products. Agilent offers open connectivity for a broad range of system-ready instruments, open industry software, PC-standard I/O and global support, which are combined to more easily integrate test system development.

LXI is the U.S. registered trademark of the LXI Consortium.

www.agilent.com

For more information on Agilent Technologies' products, applications or services, please contact your local Agilent office. The complete list is available at:

www.agilent.com/find/contactus

Phone or Fax

United States:

(tel) 800 829 4444

(fax) 800 829 4433

Canada:

(tel) 877 894 4414

(fax) 800 746 4866

China:

(tel) 800 810 0189

(fax) 800 820 2816

Europe:

(tel) 31 20 547 2111

Japan:

(tel) (81) 426 56 7832

(fax) (81) 426 56 7840

Korea:

(tel) (080) 769 0800

(fax) (080) 769 0900

Latin America:

(tel) (305) 269 7500

Taiwan:

(tel) 0800 047 866

(fax) 0800 286 331

Other Asia Pacific Countries:

(tel) (65) 6375 8100

(fax) (65) 6755 0042

Email: tm_ap@agilent.com

Revised: 11/08/06

Product specifications and descriptions in this document subject to change without notice.

© Agilent Technologies, Inc. 2007

Printed in USA, April 1, 2007

5989-6205EN



Agilent Technologies