

Agilent N4915A-005 Serial Bus Switch

Data Sheet

Version 1.1

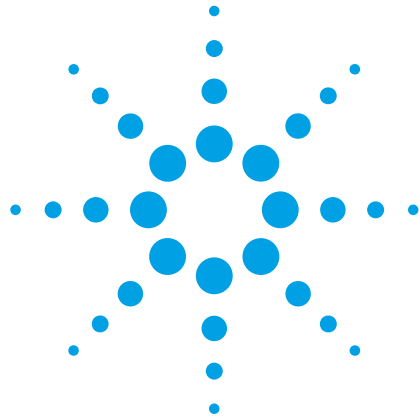

6.5 GBit/s 2 to 1 switch for high speed differential signals

- Low effect on signal integrity allows for usage in physical layer test setups
- Fast switching time (6ns typical)
- Manual and triggered operation
- Supported by Agilent N5990A test automation software
- No external power supply required

Overview

The N4915A-005 serial bus switch is designed for high speed serial bus applications, such as for example Serial-ATA and PCI Express. It can quickly switch between one source and two sink devices or one sink and two sources while having a minimal effect on signal integrity.

Serial Bus Interface

The switch is designed for switching a differential signal as typically used in high speed serial bus applications. Therefore the switch comes with two channels that switch simultaneously.

Figure 1 illustrates a typical setup with two transmitters that are switched between one receiver. Analogously two receivers can be switched between one transmitting device.

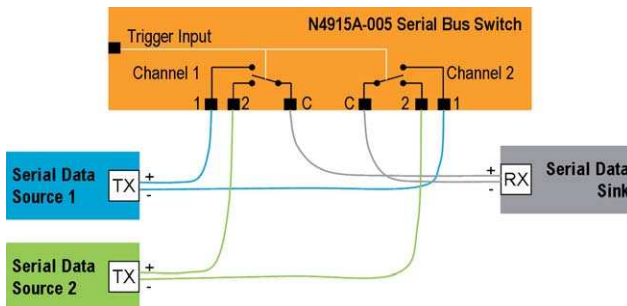

Figure 1: Typical switch setup with two transmitters

For both channels the common connector (labeled “C”) will be switched between connector “1” and “2”. The switch position display will indicate the current switch state by either illuminating a red (connector 1) or a green (connector 2) LED.



Figure 2: N4915A-005 connector view

Power Supply

The switch doesn’t require any power supply, it operates solely on USB power via its back side mini USB connector. It interfaces to any standard USB host, as provided by many Agilent instruments or by any standard PC. It doesn’t require any host software or driver installation.

The switch doesn’t have a dedicated power indicator. As soon as one of the switch position and one of the trigger mode LEDs are illuminated the switch is powered and in normal operation.

Table 1: N4915A-005 electrical characteristics

Parameter	Value	Note
Max. usable data rate	6.5 GBit/s	
Signal inputs/outputs	AC coupled	100 nF at each connector
Max. signal amplitude per channel	1V @ 70 kHz to 12 GHz 2V @ 100 MHz to 12 GHz	
Max. signal amplitude two channels differential	2V @ 70 kHz to 12 GHz 4V @ 100 MHz to 12 GHz	
Signal attenuation	1.5 dB (15%) typical	at 6 GBit/s
Transition times (20%-80%)	40 ps typical	when used with J-BERT N4903A
Switching time	6 ns typical	
Total jitter (p-p)	20 ps typical	¹⁾
Skew between channels	2 ps typical	
Connectors	SMA, 3.5 mm female	
Power supply	USB	

1) Total jitter was measured with J-BERT N4903A and 86100C DCA-J with precision time-base using the following settings: BER 10^{-12} , data rate 3 GBit/s, pattern $2^{15}-1$ PRBS

Operation Modes

The switch is controlled by four buttons on the front panel. Its current operation mode and switch position are illustrated by front panel LEDs.

Both trigger modes make use of the trigger input. The trigger mode buttons allow the user to switch between a level static trigger mode and an edge trigger mode. In edge trigger mode the manual pre-set buttons are also active. As an edge trigger toggles between the two switch positions the pre-set function allows the switch to initialize at a desired state. For a manual only operation the edge/man trigger mode will be used and the trigger input will remain open.

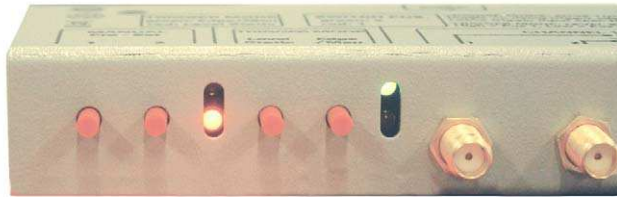

Figure 3: N4915A-005 front view with status LEDs

Trigger Input

The trigger input is designed to be interoperable with Agilent Bit Error Ratio Testers such as the J-BERT N4903A as well as Agilent Pulse Pattern Generators such as the 81134A. For usage with J-BERT's trigger output choose the edge trigger mode. When connecting to the output of a Pulse Pattern Generator the level static mode can be used.

Table 2: N4915A-005 trigger input electrical parameters

Parameter	Value
Trigger input max. levels	$\pm 3V$
Trigger threshold	10 mV
Max. trigger rate	10 MHz
Trigger input connector	SMA, 3.5 mm female

Usage in Test Automation and Serial-ATA Receiver Compliance Test

Because of its external trigger modes the switch can be controlled by other test equipment. Test equipment with integrated sequencing capabilities, such as the J-BERT N4903A can control the switch position as part of a pattern sequence. Furthermore, setups with multiple channels, such as the 81134A Pulse Pattern Generator or the ParBERT 81250 systems can dedicate a data channel to control the switch.

Some test applications require the user to change cables between tools, for example in Serial-ATA receiver compliance testing, different tools are needed for turning on the test mode and for performing the actual test. Without a serial bus switch this requires a change of cables as part of the test procedure.

Changing cables is certainly undesired in test automation as it consumes additional time and labor. In order to avoid connectivity errors and preserve mechanically sensitive test fixtures, setup changes should also be avoided.

Therefore in Serial-ATA the N5990A test automation software has capabilities to remotely control two switch devices to avoid manual steps.

Besides test automation in Serial-ATA the switches also overcome the device disconnect issue: After the test mode is turned on on a Serial-ATA product, it doesn't necessarily allow the user to manually change the connectors. Being disconnected causes some devices to return to the out-of-band mode. Such products can still be tested when using the serial bus switch. Because of the fast switching time Serial-ATA products won't detect a signal loss while being switched between test tools.

Ordering Information

6.5 GBit/s 2 to 1 serial bus switch N4915A-005

Related Agilent Literature

Agilent N4915A-005 Serial Bus Switch Application in SATA Receiver Test Application Note

Agilent J-BERT N4903A High-Performance Serial BERT with Complete Jitter Tolerance Testing Data Sheet

BERT Family Brochure Brochure

Agilent ParBERT 81250 Parallel Bit Error Ratio Tester Product Overview

Agilent Pulse Pattern and Data Generators Brochure

Agilent 81133A and 81134A 3.35 GHz Pulse Pattern Generators Data Sheet

Agilent N5990A Test Automation Software Platform Data Sheet

For more information, please visit us at



Product specifications and descriptions in this document are subject to change without any notice.

For the latest version of this document, please visit our website at www.agilent.com/find/sata_rx_test and go to the KEY Library information area or insert the publication number (5989-7328EN) into the search engine.



Agilent Email Updates

www.agilent.com/find/emailupdates

Get the latest information on the products and applications you select.



Agilent Direct

www.agilent.com/find/agilentdirect

Quickly choose and use your test equipment solutions with confidence.

Pub.No.

5989-7532EN

5989-2899EN

5988-9514EN

5968-9188E

5980-0489E

5988-5549EN

5989-5483EN

Remove all doubt

Our repair and calibration services will get your equipment back to you, performing like new, when promised. You will get full value out of your Agilent equipment throughout its lifetime. Your equipment will be serviced by Agilent-trained technicians using the latest factory calibration procedures, automated repair diagnostics and genuine parts. You will always have the utmost confidence in your measurements. Agilent offers a wide range of additional expert test and measurement services for your equipment, including initial start-up assistance onsite education and training, as well as design, system integration, and project management.

For more information on repair and calibration services, go to:

www.agilent.com/find/removealldoubt



www.agilent.com/find/open

Agilent Open simplifies the process of connecting and programming test systems to help engineers design, validate and manufacture electronic products. Agilent offers open connectivity for a broad range of system-ready instruments, open industry software, PC-standard I/O and global support, which are combined to more easily integrate test system development.

For more information on Agilent Technologies' products, applications or services, please contact your local Agilent office. The complete list is available at:

www.agilent.com/find/contactus

Phone or Fax

United States:
(tel) 800 829 4444
(fax) 800 829 4433

Canada:
(tel) 877 894 4414
(fax) 800 746 4866

China:
(tel) 800 810 0189
(fax) 800 820 2816

Europe:
(tel) 31 20 547 2111

Japan:
(tel) (81) 426 56 7832
(fax) (81) 426 56 7840

Korea:
(tel) (080) 769 0800
(fax) (080)769 0900

Latin America:
(tel) (305) 269 7500

Taiwan:
(tel) 0800 047 866
(fax) 0800 286 331

Other Asia Pacific Countries:
(tel) (65) 6375 8100
(fax) (65) 6755 0042
Email: tm_ap@agilent.com
Revised: 09/14/06

© Agilent Technologies, Inc. 2007
Printed in USA, October 30th 2007

5989-7328EN



Agilent Technologies