

# Agilent HMMC-3122 DC-12 GHz Packaged High Efficiency Divide-by-2 Prescaler

1GC1-8209-TR1-7" diameter reel/500 each  
1GC1-8209-BLK-bubble strip/10 each

Data Sheet

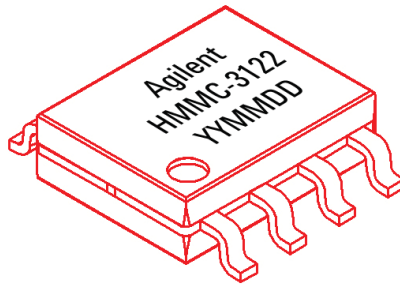

Package Type: 8-lead SOIC Plastic  
Package Dimensions: 4.9 x 3.9 mm typ.  
Package Thickness: 1.55 mm typ.  
Lead Pitch: 1.25 mm nom.  
Lead Width: 0.42 mm nom.

## Features

- **Wide Frequency Range:**  
0.2-12 GHz
- **High Input Power Sensitivity:**  
On-chip pre- and post-amps  
-15 to +10 dBm (1-8 GHz)  
-10 to +8 dBm (8-10 GHz)  
-5 to +2 dBm (10-12 GHz)
- **P<sub>out</sub>: 0 dBm (0.5 V<sub>p-p</sub>)**
- **Low Phase Noise:**  
-153 dBc/Hz @ 100 kHz Offset
- **(+) or (-) Single Supply Bias Operation**
- **Wide Bias Supply Range:**  
4.5 to 6.5 volt operating range
- **Differential I/O with on-chip 50 Ω matching**

## Description

The HMMC-3122 is a packaged GaAs HBT MMIC pre-scaler which offers dc to 12 GHz frequency translation for use in communications and EW systems incorporating high-frequency PLL oscillator circuits and signal-path down conversion applications. The prescaler provides a large input power sensitivity window and low phase noise.

## Absolute Maximum Ratings<sup>1</sup>

(@ T<sub>A</sub> = 25°C, unless otherwise indicated)

Symbol	Parameters/Conditions	Min.	Max.	Units
V <sub>CC</sub>	Bias supply voltage		+7	volts
V <sub>EE</sub>	Bias supply voltage	-7		volts
V <sub>CC</sub> - V <sub>EE</sub>	Bias supply delta	0	+7	volts
V <sub>Logic</sub>	Logic threshold voltage	V <sub>CC</sub> -1.5	V <sub>CC</sub> -1.2	volts
P <sub>in(CW)</sub>	CW RF input power		+10	dBm
V <sub>RFIn</sub>	DC input voltage (@ RF <sub>in</sub> or $\overline{\text{RF}}_{\text{in}}$ ports)		V <sub>CC</sub> ±0.5	volts
T <sub>BS</sub> <sup>2</sup>	Backside operating temperature	-40	+85	°C
T <sub>st</sub>	Storage temperature	-65	+165	°C
T <sub>max</sub>	Maximum assembly temperature (60 s max.)		310	°C

### Notes

1. Operation in excess of any parameter limit (except T<sub>BS</sub>) may cause permanent damage to the device.
2. MTTF > 1 x 10<sup>6</sup> hours @ T<sub>BS</sub> ≤ 85°C. Operation in excess of maximum operating temperature (T<sub>BS</sub>) will degrade MTTF.



Agilent Technologies

## DC Specifications/Physical Properties

( $T_A = 25^\circ\text{C}$ ,  $V_{CC} - V_{EE} = 5.0$  volts, unless otherwise listed)

Symbol	Parameters/Conditions	Min.	Typ.	Max.	Units
$V_{CC} - V_{EE}$	Operating bias supply difference <sup>1</sup>	4.5	5.0	6.5	volts
$ I_{CC} $ or $ I_{EE} $	Bias supply current	34	40	46	mA
$V_{RFIn(q)}$ $V_{RFout(q)}$	Quiescent dc voltage appearing at all RF ports		$V_{CC}$		volts
$V_{Logic}$	Nominal ECL Logic Level ( $V_{Logic}$ contact self-bias voltage, generated on-chip)	$V_{CC} - 1.45$	$V_{CC} - 1.32$	$V_{CC} - 1.25$	volts

### Notes

1. Prescaler will operate over full specified supply voltage range,  $V_{CC}$  or  $V_{EE}$  not to exceed limits specified in Absolute Maximum Ratings section.

## RF Specifications

( $T_A = 25^\circ\text{C}$ ,  $Z_0 = 50 \Omega$ ,  $V_{CC} - V_{EE} = 5.0$  volts)

Symbol	Parameters/Conditions	Min.	Typ.	Max.	Units
$f_{in(max)}$	Maximum input frequency of operation	12	14		GHz
$f_{in(min)}$	Minimum input frequency of operation <sup>1</sup> ( $P_{in} = -10$ dBm)		0.2	0.5	GHz
$f_{Self-Osc.}$	Output Self-Oscillation Frequency <sup>2</sup>		3.4		GHz
$P_{in}$	@ dc, (Square-wave input)	-15	> -25	+10	dBm
	@ $f_{in} = 500$ MHz, (Sine-wave input)	-15	> -20	+10	dBm
	$f_{in} = 1$ to 8 GHz	-15	> -20	+10	dBm
	$f_{in} = 8$ to 10 GHz	-10	> -15	+5	dBm
	$f_{in} = 10$ to 12 GHz	-5	> -10	+1	dBm
RL	Small-Signal Input/Output Return Loss (@ $f_{in} < 10$ GHz)		15		dB
$S_{12}$	Small-Signal Reverse Isolation (@ $f_{in} < 10$ GHz)		30		dB
$\Phi_N$	SSB Phase noise (@ $P_{in} = 0$ dBm, 100 kHz offset from a $f_{out} = 1.2$ GHz Carrier)		-153		dBc/Hz
Jitter	Input signal time variation @ zero-crossing ( $f_{in} = 10$ GHz, $P_{in} = -10$ dBm)		1		ps
$T_r$ or $T_f$	Output transition time (10% to 90% rise/fall time)		70		ps

### Notes

1. For sine-wave input signal. Prescaler will operate down to dc for square-wave input signal. Minimum divide frequency limited by input slew-rate.

2. Prescaler may exhibit this output signal under bias in the absence of an RF input signal. This condition may be eliminated by use of the Input dc offset technique described on page 4.

## RF Specifications (Continued)

( $T_A = 25^\circ\text{C}$ ,  $Z_0 = 50 \Omega$ ,  $V_{CC} - V_{EE} = 5.0$  volts)

Symbol	Parameters/Conditions	Min.	Typ.	Max.	Units
$P_{out}^3$	@ $f_{out} < 1$ GHz	-2	0		dBm
	@ $f_{out} = 2.5$ GHz	-3.5	-1.5		dBm
	@ $f_{out} = 3.0$ GHz	-4.5	-2.5		dBm
$ V_{out(p-p)} ^4$	@ $f_{out} < 1$ GHz		0.5		volts
	@ $f_{out} = 2.5$ GHz		0.42		volts
	@ $f_{out} = 3.0$ GHz		0.37		volts
$P_{Spitback}$	$f_{out}$ power level appearing at $RF_{in}$ or $\overline{RF}_{in}$ (@ $f_{in} = 10$ GHz, unused $RF_{out}$ or $\overline{RF}_{out}$ <b>unterminated</b> )		-50		dBm
	$f_{out}$ power level appearing at $RF_{in}$ or $\overline{RF}_{in}$ (@ $f_{in} = 10$ GHz, both $RF_{out}$ & $\overline{RF}_{out}$ <b>terminated</b> )		-55		dBm
$P_{feedthru}$	Power level of $f_{in}$ appearing at $RF_{out}$ or $\overline{RF}_{out}$ (@ $f_{in} = 12$ GHz, $P_{in} = 0$ dBm, referred to $P_{in}(f_{in})$ )		-30		dBc
$H_2$	Second harmonic distortion output level (@ $f_{out} = 3.0$ GHz, referred to $P_{out}(f_{out})$ )		-25		dBc

### Notes

- Fundamental of output square wave's Fourier Series.
- Square wave amplitude calculated from  $P_{out}$ .

## Applications

The HMMC-3122 is designed for use in high frequency communications, microwave instrumentation, and EW radar systems where low phase-noise PLL control circuitry or broad-band frequency translation is required.

## Operation

The device is designed to operate when driven with either a single-ended or differential sinusoidal input signal over a 200 MHz to 12 GHz bandwidth. Below 200 MHz the prescaler input is "slew-rate" limited, requiring fast rising and falling edge speeds to properly divide. The device will operate at frequencies down to dc when driven with a square-wave.

age (connected to the  $V_{CC}$  contact on the device), and the unique design of the device itself, the component may be biased from either a single positive or single negative supply bias. The backside of the package is not dc connected to any dc bias point on the device.

For positive supply operation,  $V_{CC}$  pins are nominally biased at any voltage in the +4.5 to +6.5 volt range with pin 8 ( $V_{EE}$ ) grounded. For negative bias operation  $V_{CC}$  pins are typically grounded and a negative voltage between -4.5 to -6.5 volts is applied to pin 8 ( $V_{EE}$ ).

## AC-Coupling and DC-Blocking

All RF ports are dc connected on-chip to the  $V_{CC}$  contact through on-chip 50  $\Omega$  resistors. Under any bias conditions where  $V_{CC}$  is not dc grounded the RF ports should be ac coupled via series capacitors mounted on the PC board at each RF port. Only under bias conditions where  $V_{CC}$  is dc grounded (as is typical for negative bias supply operation) may the RF ports be direct coupled to adjacent circuitry or in some cases, such as level shifting to subsequent stages. In the latter case the package heat sink may be "floated" and bias applied as the difference between  $V_{CC}$  and  $V_{EE}$ .

Due to the presence of an off-chip RF-bypass capacitor inside the pack-

## Input DC Offset

If an RF signal with sufficient signal to noise ratio is present at the RF input lead, the prescaler will operate and provide a divided output equal the input frequency divided by the divide modulus. Under certain “ideal” conditions where the input is well matched at the right input frequency, the component may “self-oscillate”, especially under small signal input powers or with only noise present at the input. This “self-oscillation” will produce an undesired output signal also known as a false trigger. To prevent false triggers or self-oscillation conditions, apply a 20 to 100 mV dc offset voltage between the RF<sub>in</sub> and RF<sub>in</sub> ports. This prevents noise or spurious low level signals from triggering the divider.

Adding a 10 kΩ resistor between the unused RF input to a contact point at the V<sub>EE</sub> potential will result in an offset of ≈ 25 mV between the RF inputs. Note however, that the input sensitivity will be reduced slightly due to the presence of this offset.

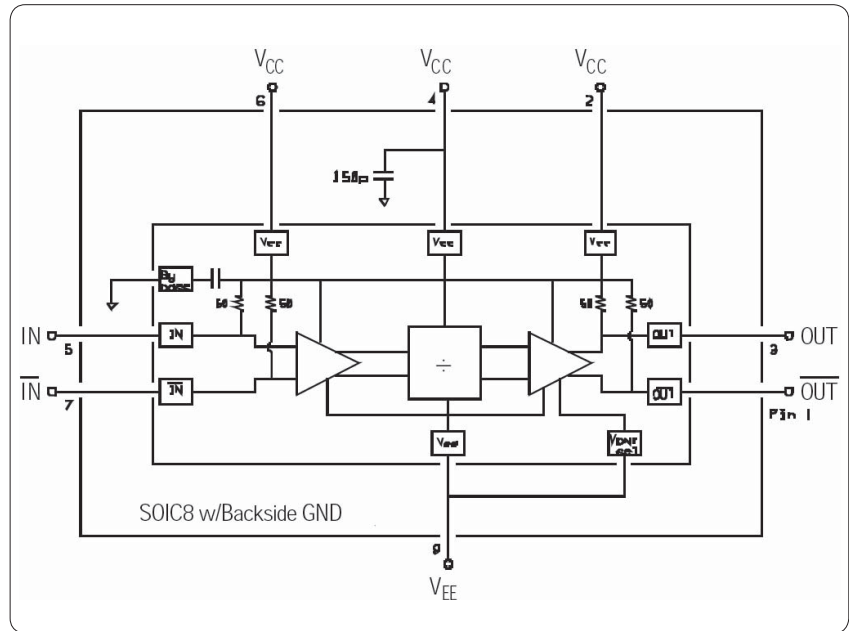

Figure 1. Simplified Schematic

## Assembly Notes

Independent of the bias applied to the package, the backside of the package should always be connected to both a good RF ground plane and a good thermal heat sinking region on the PC board to optimize performance. For single-ended output operation the unused RF output lead should be terminated into 50 Ω to a contact point at the V<sub>CC</sub> potential or to RF ground through a dc blocking capacitor.

A minimum RF and thermal PC board contact area equal to or greater than 2.67 × 1.65 mm (0.105" × 0.065") with eight 0.020" diameter plated-wall thermal vias is recommended.

MMIC ESD precautions, handling considerations, die attach and bonding methods are critical factors in successful GaAs MMIC performance and reliability.

Agilent application note #54, “GaAs MMIC ESD, Die Attach and Bonding Guidelines” provides basic information on these subjects.

Moisture Sensitivity Classification: Class 1, per JESD22-A112-A.

## Additional References:

PN #18, “HBT Prescaler Evaluation Board.”

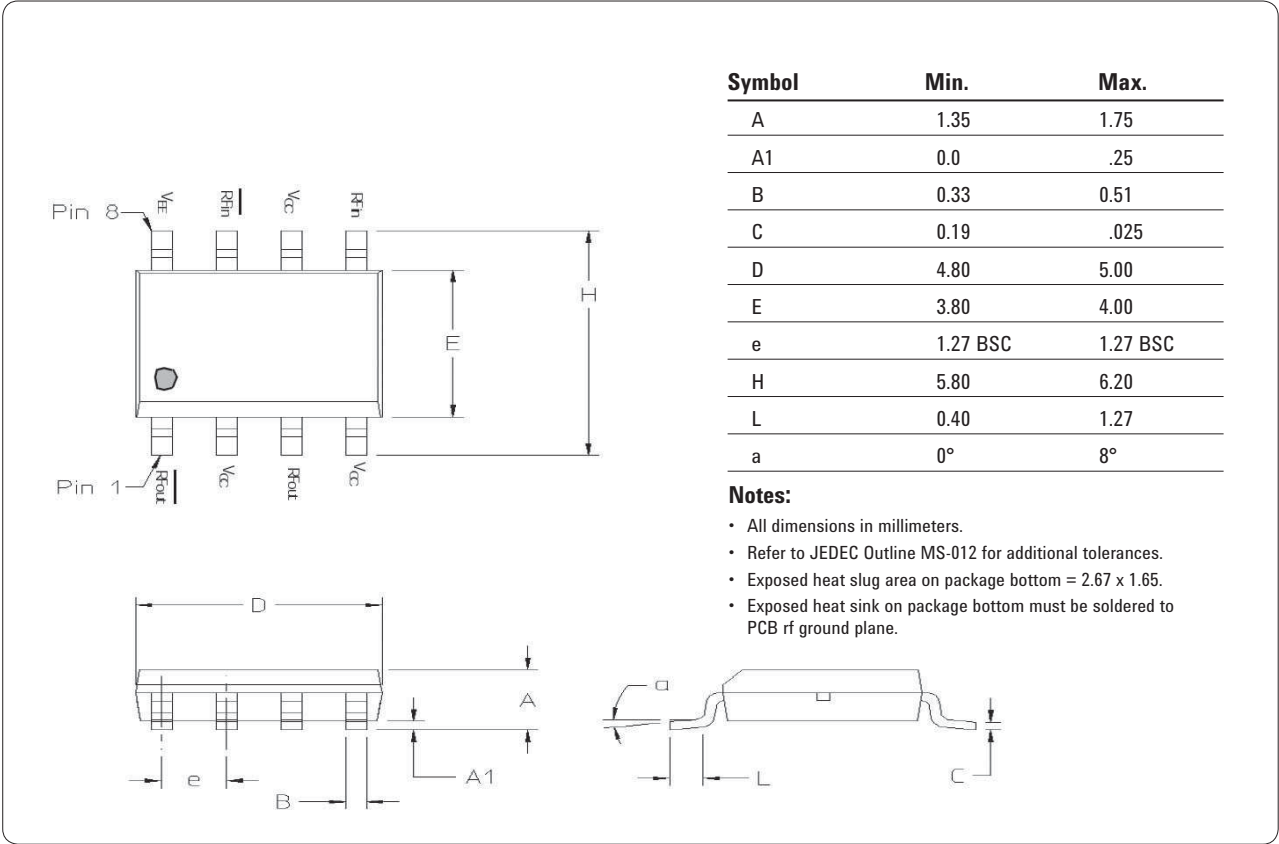

Figure 2. Package and dimensions

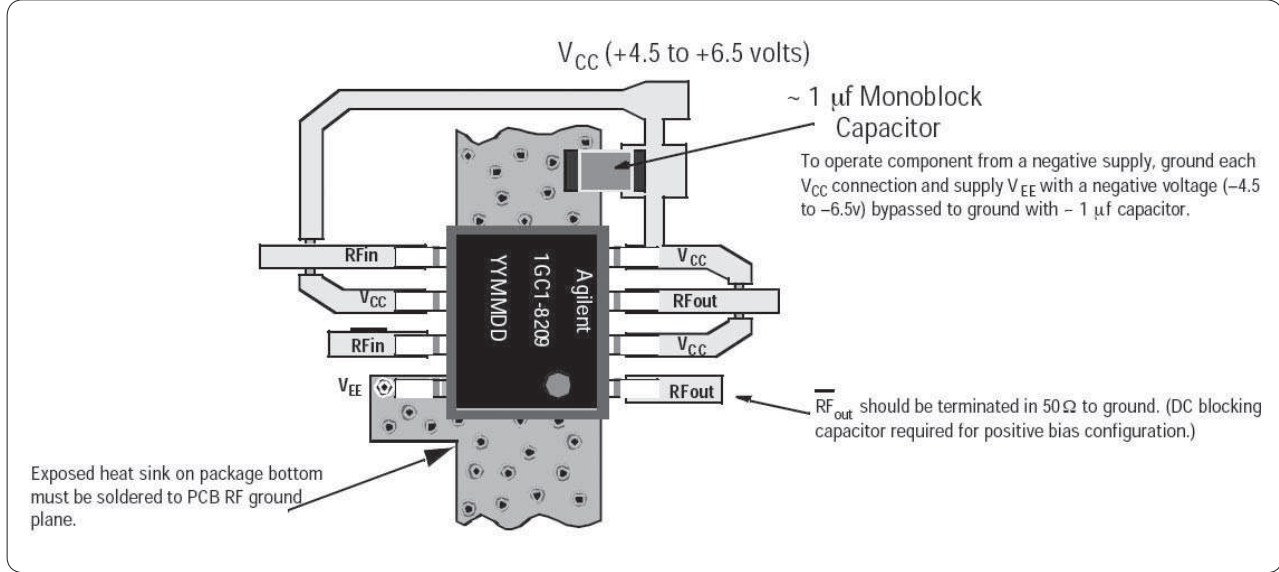

Figure 3. Assembly diagram (Single-supply, positive-bias configuration shown)

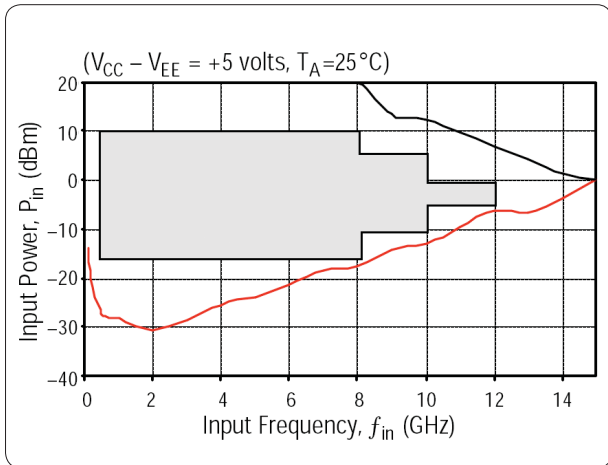

Figure 4. Typical input sensitivity window

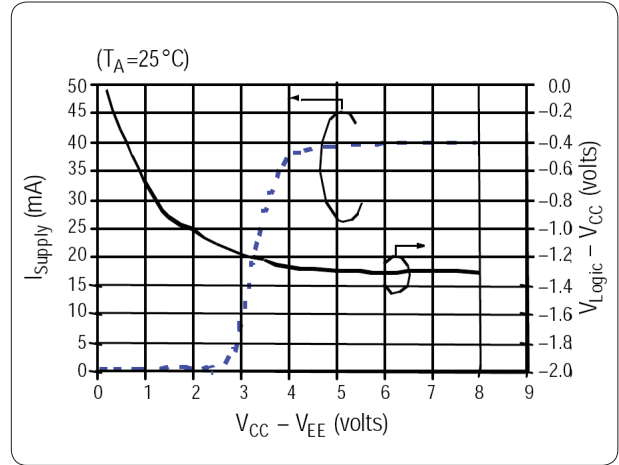

Figure 5. Typical supply current &  $V_{\text{Logic}}$  vs. supply voltage

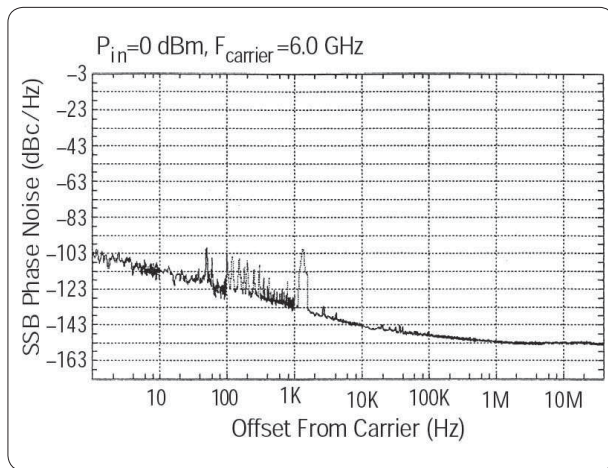

Figure 6. Typical phase noise performance

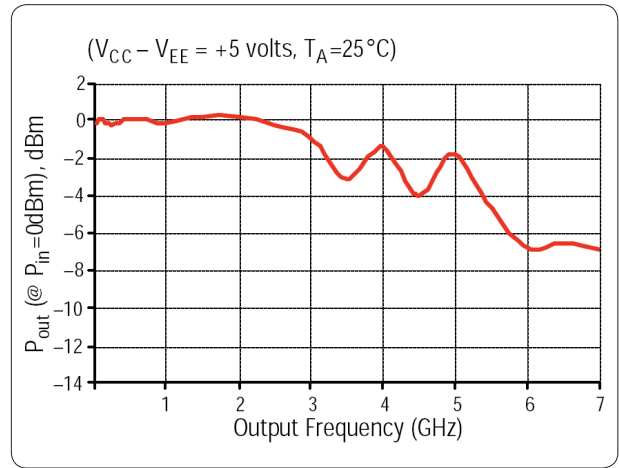

Figure 7. Typical output power vs. output frequency,  $f_{out}$  (GHz)

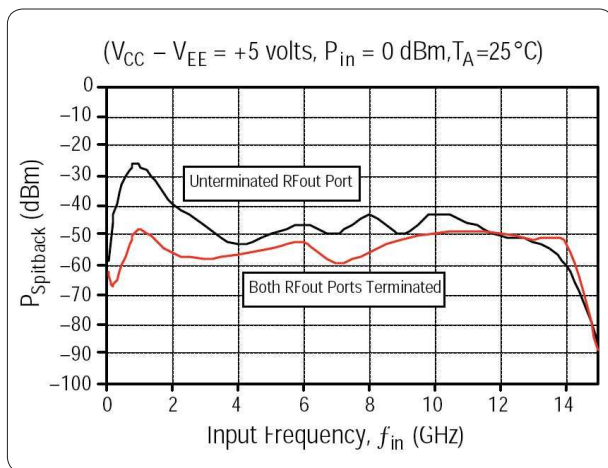
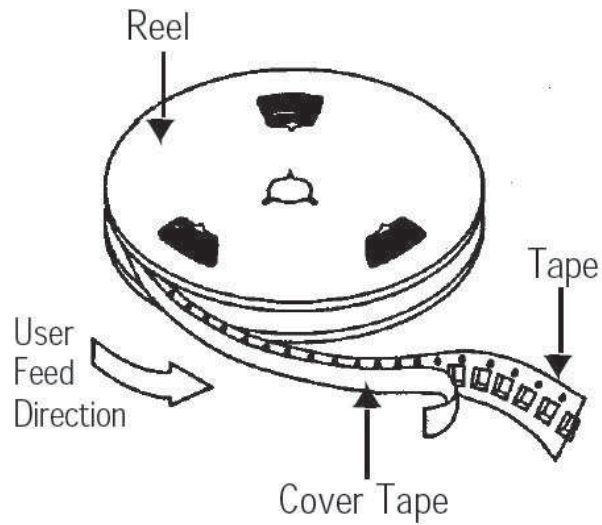
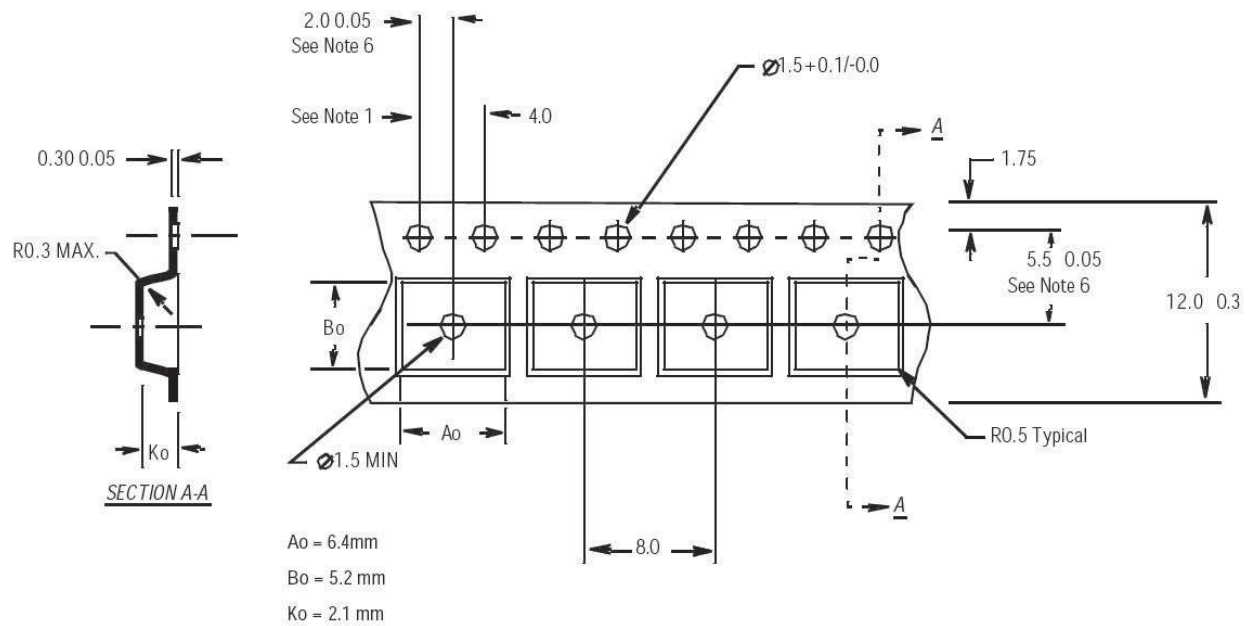

Figure 8. Typical "Spitback" power  $P(f_{out})$  appearing at RF input port

## Device Orientation



## Tape Dimensions and Product Orientation





### Agilent Email Updates

[www.agilent.com/find/emailupdates](http://www.agilent.com/find/emailupdates)  
Get the latest information on the products and applications you select.



### Agilent Direct

[www.agilent.com/find/agilentdirect](http://www.agilent.com/find/agilentdirect)  
Quickly choose and use your test equipment solutions with confidence.



### Agilent Open

[www.agilent.com/find/open](http://www.agilent.com/find/open)  
Agilent Open simplifies the process of connecting and programming test systems to help engineers design, validate and manufacture electronic products. Agilent offers open connectivity for a broad range of system-ready instruments, open industry software, PC-standard I/O and global support, which are combined to more easily integrate test system development.



### LXI

[www.lxistandard.org](http://www.lxistandard.org)  
LXI is the LAN-based successor to GPIB, providing faster, more efficient connectivity. Agilent is a founding member of the LXI consortium.

This data sheet contains a variety of typical and guaranteed performance data. The information supplied should not be interpreted as a complete list of circuit specifications. Customers considering the use of this, or other Agilent GaAs ICs, for their design should obtain the current production specifications from Agilent. In this data sheet the term typical refers to the 50th percentile performance. For additional information contact Agilent

[MMIC\\_Helpline@agilent.com](mailto:MMIC_Helpline@agilent.com).

## www.agilent.com

For more information on Agilent Technologies' products, applications or services, please contact your local Agilent office. The complete list is available at:

[www.agilent.com/find/contactus](http://www.agilent.com/find/contactus)

#### Americas

Canada	(877) 894-4414
Latin America	305 269 7500
United States	(800) 829-4444

#### Asia Pacific

Australia	1 800 629 485
China	800 810 0189
Hong Kong	800 938 693
India	1 800 112 929
Japan	81 426 56 7832
Korea	080 769 0800
Malaysia	1 800 888 848
Singapore	1 800 375 8100
Taiwan	0800 047 866
Thailand	1 800 226 008

#### Europe

Austria	0820 87 44 11
Belgium	32 (0) 2 404 93 40
Denmark	45 70 13 15 15
Finland	358 (0) 10 855 2100
France	0825 010 700
Germany	01805 24 6333*
	*0.14€/minute
Ireland	1890 924 204
Italy	39 02 92 60 8484
Netherlands	31 (0) 20 547 2111
Spain	34 (91) 631 3300
Sweden	0200-88 22 55
Switzerland (French)	41 (21) 8113811(Opt 2)
Switzerland (German)	0800 80 53 53 (Opt 1)
United Kingdom	44 (0) 118 9276201

Other European Countries:

[www.agilent.com/find/contactus](http://www.agilent.com/find/contactus)

Revised: May 7, 2007

Product specifications and descriptions in this document subject to change without notice.

© Agilent Technologies, Inc. 2007  
Printed in USA, November 26, 2007  
5989-7352EN

