

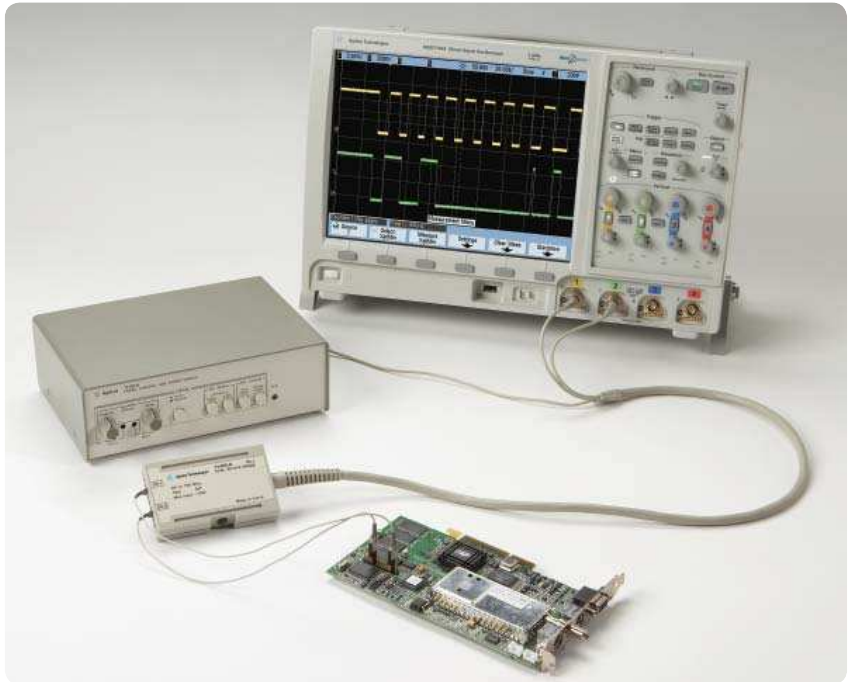

Agilent 1145A Two-Channel, 750-MHz, Small-Geometry Active Probe for Surface-Mount Devices

Data Sheet



SMD package and other support

- Signal-ground pairs with 100-mil spacing
- 50-mil SOIC and QUAD packages
- 25-mil square pin socket on basic tip mates with most industry standard IC package adapters
- 25-mil JEDEC, 0.5-mm EIAJ, 0.65-mm EIAJ packages

Instrument compatibility

- Powered directly by Agilent Technologies 54520A, 54522A, 54540A, and 54542A oscilloscopes
- Compatible with oscilloscope's 50 ohm BNC input. Use the Agilent 1142A external power supply with any other instrument with 50 Ω inputs.

Features

- 2 channels per assembly
- dc to 750-MHz probe bandwidth
- 1-M Ω input resistance
- 1.6-pF input capacitance
- 10X attenuation



Agilent Technologies

Surface-mount packages on PC boards have become the norm rather than the exception. In the future, nearly 100 percent of both sides of a typical PC board will use SMDs. As a result, bulky probes may become useless as package sizes get smaller and smaller.

The 2-channel Agilent 1145A provides easy and reliable connection to SMDs on PC boards and backplanes, while delivering active probe performance down to the tip. Its unique design also presents a powerful combination of industry-standard compatibility and superior reliability. The probe's basic contact is a standard 25-mil square pin socket that houses only passive circuitry. The active circuitry is contained in a plastic pod 13 inches from the tip. This design ensures a small, lightweight, and rugged tip.

The electrical performance of the 1145A is unmatched by any off-the-shelf probe designed for SMD probing. The probe combines high bandwidth, high input resistance, and low input capacitance. This combination is superior to that of passive divider probes that have higher input capacitance because it provides minimal circuit loading at high and low frequencies (see the Impedance vs. Frequency graph). As signal speeds increase, passive divider probes don't deliver the performance needed. This lower performance can result in waveshapes that do not represent the actual signal. The 1145A used with an 54542A scope, for example, introduces the equivalent of only $\frac{1}{2}$ of a typical CMOS gate load (approximately 3.0 pF per gate) to a CMOS circuit. Other SMD probes used with comparable scopes can introduce $1\frac{1}{2}$ or more gate loads to the circuit under test.



SMT grabbers provide solid connection to leads with down to 50-mil spacings

A versatile set of accessories lets you probe most any SMD package. The standard socket also makes the 1145A compatible with probing adapters from other vendors for fault-free probing of SMDs including 5-mil JEDEC, 0.5-mm EIAJ, 0.65-mm EIAJ packages.

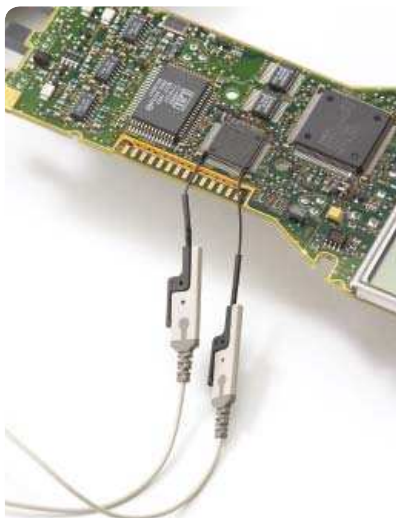

Flexible SMT leads can be soldered to any convenient signal access point

Specifications

Bandwidth ¹	≥ 750 MHz
RiseTime ^{1,2}	≤ 470 ps
Attenuation ³	10:1 ± 3%
Input resistance	1 MΩ ± 2%
Maximum input voltage	± 40 V (dc + peak ac)

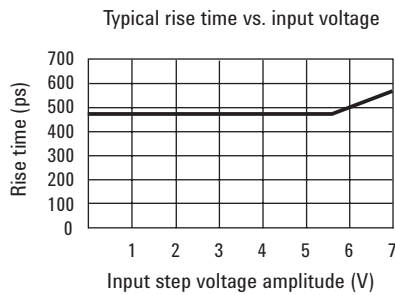
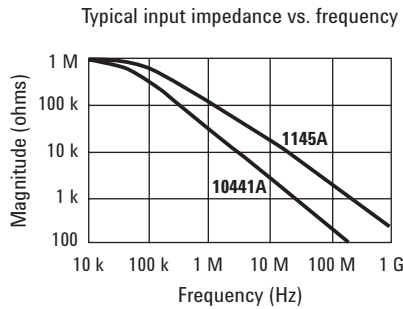

Characteristics

Input capacitance	1.6 pF (typical)
Overshoot and ringing ⁴	± 10 % for the first 6 ns, ± 4% from 6 ns to 20 ns, ± 1.5% thereafter
Output voltage offset	< ± 10 mV
Input dynamic range	± 6.0 V
Output load requirement	50 Ω

General characteristics

Environmental conditions

Temperature	
Operating	0 °C to +55 °C (32 °F to +131 °F)
Nonoperating	-40 °C to +70 °C (-40 °F to +158 °F)
Humidity	
Operating	Up to 95% relative humidity (non-condensing) at +40 °C (+104 °F)
Nonoperating	Up to 90% relative humidity at +65 °C (+149 °F)
Altitude	
Operating	Up to 4,600 meters (15,000 ft)
Nonoperating	Up to 15,300 meters (50,000 ft)
Vibration	Random vibration 5 to 500 Hz, 10 minutes per axis, 0.3 grms. Random vibration 5 to 500 Hz, 10 minutes per axis, 2.41 grms. Resonant search 5 to 500 Hz swept sine, 1 octave/min. sweep rate, (0.75 g), 5 min. resonant dwell at 4 resonances per axis.
Power requirements	±6 V dc ± 2% (at approximately 180 mA each supply)
Weight	
Net	Approximately 8 oz
Shipping	Approximately 1 kg (2.2 lb)
Dimensions	Refer to the 1145A drawing

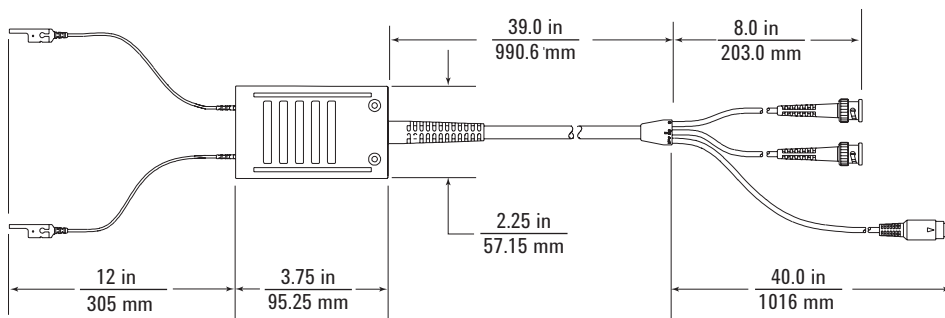

1145A dimensions

1. Above 35 °C, bandwidth and rise time degrade approximately ½%/°C.
2. Rise time figure calculated from $tr = 0.35/\text{Bandwidth}$.
3. When connected to an instrument input of 50 Ω, ±0.5%.
4. Oscilloscope characteristics excluded.

Ordering information

1145A	Active probe Accessory kit that contains 4 probing pins, 5 SMT grabbers, 2 ground extenders, 2 ground leads with pin-sockets, and 2 red and 2 black solderable SMT leads. User and Service Guide, one-year warranty
-------	--

Available accessories

16517-8210	Kit with 4 probing pins
5090-4356	SMT grabber kit with 20 grabbers
16517-82105	Ground extender kit with 20 extenders
16517-82106	Ground lead with pin-socket kit with 20 leads
16517-82104	SMT lead kit with 4 red and 4 black leads

Also available

1142A	Probe control and power supply module. Includes: power cord, one-year warranty Note: Offset and coupling control is not usable with 1145A
01145-68701	Cal kit. Includes: 50 Ω feedthrough termination, SMA adapter



Agilent Technologies Oscilloscopes

Multiple form factors from 20 MHz to > 90 GHz | Industry leading specs | Powerful applications

 **Agilent Email Updates**

www.agilent.com/find/emailupdates
Get the latest information on the products and applications you select.

 **Agilent Direct**

www.agilent.com/find/agilentdirect
Quickly choose and use your test equipment solutions with confidence.

Agilent
Open 

www.agilent.com/find/open
Agilent Open simplifies the process of connecting and programming test systems to help engineers design, validate and manufacture electronic products. Agilent offers open connectivity for a broad range of system-ready instruments, open industry software, PC-standard I/O and global support, which are combined to more easily integrate test system development.

LXI

www.lxistandard.org
LXI is the LAN-based successor to GPIB, providing faster, more efficient connectivity. Agilent is a founding member of the LXI consortium.

Remove all doubt

Our repair and calibration services will get your equipment back to you, performing like new, when promised. You will get full value out of your Agilent equipment throughout its lifetime. Your equipment will be serviced by Agilent-trained technicians using the latest factory calibration procedures, automated repair diagnostics and genuine parts. You will always have the utmost confidence in your measurements. For information regarding self maintenance of this product, please contact your Agilent office.

Agilent offers a wide range of additional expert test and measurement services for your equipment, including initial start-up assistance, onsite education and training, as well as design, system integration, and project management.

For more information on repair and calibration services, go to:

www.agilent.com/find/removealldoubt

Product specifications and descriptions in this document subject to change without notice.

For more information on Agilent Technologies' products, applications or services, please contact your local Agilent office. The complete list is available at:

www.agilent.com/find/contactus

Americas

Canada	(877) 894-4414
Latin America	305 269 7500
United States	(800) 829-4444

Asia Pacific

Australia	1 800 629 485
China	800 810 0189
Hong Kong	800 938 693
India	1 800 112 929
Japan	0120 (421) 345
Korea	080 769 0800
Malaysia	1 800 888 848
Singapore	1 800 375 8100
Taiwan	0800 047 866
Thailand	1 800 226 008

Europe & Middle East

Austria	01 36027 71571
Belgium	32 (0) 2 404 93 40
Denmark	45 70 13 15 15
Finland	358 (0) 10 855 2100
France	0825 010 700*
	*0.125 €/minute
Germany	07031 464 6333
Ireland	1890 924 204
Israel	972-3-9288-504/544
Italy	39 02 92 60 8484
Netherlands	31 (0) 20 547 2111
Spain	34 (91) 631 3300
Sweden	0200-88 22 55
Switzerland	0800 80 53 53
United Kingdom	44 (0) 118 9276201

Other European Countries:

www.agilent.com/find/contactus

Revised: October 6, 2008

© Agilent Technologies, Inc. 2008
Printed in USA, December 19, 2008
5968-3853E



Agilent Technologies