



HEWLETT  
PACKARD

pA Meter/  
DC Voltage Source

4140B



Technical Data, July 1980

# The Total Solution for Low Current Measurements



# Hewlett-Packard offers Advanced Technology

## Introduction

HP's 4140B pA Meter/DC Voltage Source provides a stable picoampere meter with maximum resolution of  $10^{-15}$ A and two programmable dc voltage sources. This, along with the programmable hold and step delay function, enables you to make synchronized measurements on a device or material.

Reliable, efficient pA current measurements needed in R&D labs, production, and QA can now be made with just one instrument, the 4140B. Measurements on electronic components, insulation materials, and especially semiconductor devices are fast, convenient and accomplished with ease.

## Stable Current Measurements

The 4140B makes very stable, high resolution current measurements to  $\pm 1.000 \times 10^{-12}$ A ( $1 \times 10^{-15}$ A maximum resolution) that were previously very difficult to make. The Zero offset cancels up to  $100 \times 10^{-15}$ A leakage current of test leads or fixtures in the Current (I, I-V) modes, and up to 100 pF stray capacitance in the C-V mode. The zero capability, along with low noise test leads (16053A) and electrostatic/light shielded test fixture (16055A), lets you measure low pA currents with confidence.

## Synchronized pA Measurements

Two internal programmable dc voltage sources provide staircase, ramp, and stable dc level outputs. The start, stop, and step voltages can be set from  $-100$  V to  $+100$  V with 10 mV resolution and the hold/step delay times can be set depending on the characteristics of the device or material being tested. These features, together with the pA measurement section, provide an automatically synchronized measurement.

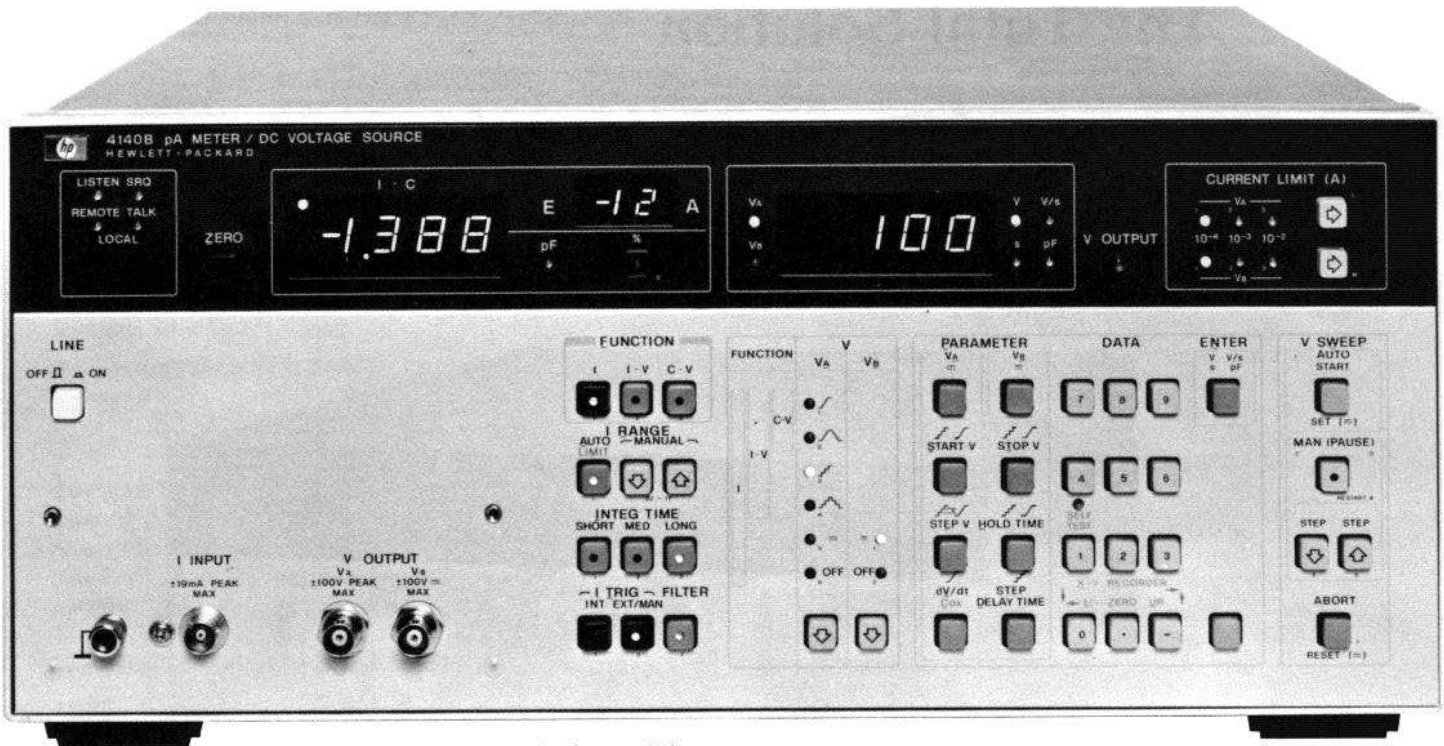

## HP-IB\* Operation

Systems integration is easily accomplished with the HP-IB interface, allowing remote programming of all front panel controls. Measurement data can be taken into the controller, processed, and then displayed in a variety of formats. This is especially effective in the manufacturing process where rapid feedback is essential.

\*HP-IB (Hewlett-Packard Interface Bus) is Hewlett-Packard's implementation of IEEE 488-1975, ANSI Standard #MC1.1.

## Selectable Function/Integration Times/Line Filter

The synchronized measurement capability allows current-voltage (I-V) and capacitance-voltage (C-V) measurements in addition to the normal pA current (I) measurements. Ranging is automatic or manual (up/down).

A significant feature is the selectable integration time (short, medium, or long). This allows a trade-off of speed vs. accuracy in current measurements.

The filter function enables accurate 1 pA measurements even when noise is 1000 times greater than the DC current being measured.

## Self Test/Analog Output

The automatic self test functionally verifies proper operation of the digital and analog circuitry.

The Analog Output supplies X-Y recorder outputs necessary for plotting I-V and C-V data. This includes measurement data, pen control, and upper and lower limit voltages.

# in Picoampere Current Measurements

## Source Current Limit

To protect the material or device under test, the 4140B has a programmable current limit capability on both internal dc sources. Current limits of  $10^{-4}$ ,  $10^{-3}$ ,  $10^{-2}$ A are selected either manually or under HP-IB control.

## Voltage Sweep Functions

Flexible voltage sweep control capability allows operator to optimize any current voltage measurement. Controls are AUTO/START, MAN (PAUSE) for changing step voltage/sweep direction during a measurement, STEP (1.1), and ABORT.



## Quasi-Static C-V Measurements

A capacitance measurement utilizing a ramp voltage (quasi-static or dc C-V measurement) is employed as one method of evaluating semiconductors. In the 4140B, capacitance is calculated from the measured current  $I$  that is synchronized with a ramp voltage  $dV/dt$  ( $C = I/dV/dt$ ). Capacitance change can also be displayed as a percent of  $C_{OX}$  (the capacitance of the oxide layer).

## Parameter Selection / Data Entry

Parameter selection and data entry is accomplished either manually from the front panel or via the HP-IB. Select the parameter (START V, STOP V, HOLD TIME...), enter the appropriate data (voltage, time, or ramp rate) and press the ENTER key. Each data entry is stored in memory. The measurement is then made automatically by pushing the START key.

## Key Features

PARAMETER MEASURED		I, I-V & C-V Can also be used as a programmable source/function generator (DC, ramp & staircase).
pA METER	DISPLAY	3 1/2 digit
	MEASUREMENT RANGE	$0.001 \times 10^{-12}A - 1.999 \times 10^{-2}A$
	BASIC ACCURACY	0.5%
	MEASUREMENT TIME	Approx. 4ms - 2.56s
	CALCULATED CAPACITANCE RANGE	0.1pF - 1999 pF
VOLTAGE SOURCE	OUTPUT MODE	V <sub>A</sub> :  V <sub>B</sub> : 
	OUTPUT RANGE	$\pm 100V$ in 10mV step Ramp Rate: 0.001 V/s - 1.000 V/s
	SWEEP MODE	AUTO/Manual (Pause)



**Model 16055A Test Fixture**

The 16055A is specially designed for low current measurements and provides both light and electrostatic shielding. The 16055A is a standard 4140B accessory.

# The Unique Features of the 4140B Offer

## ...In Evaluating Electronic Components

When automation is required, the 4140B can play a vital role in the evaluation of many kinds of electronic components on the production line. It offers picoampere current measurements that can be synchronized with internal source voltages ( $\pm 10$  mV to  $\pm 100$  V) for fast, accurate, and efficient component inspection.

### Typical Applications:

- Go/No go inspection in leakage current/insulation resistance measurements
- Temperature/humidity characteristics of leakage current

### Types of Devices:

- Capacitors (ceramic, film, paper, misc,...)
- Mechanical devices (switches, relays, connectors,...)
- Printed circuit boards
- Cables
- Transformers

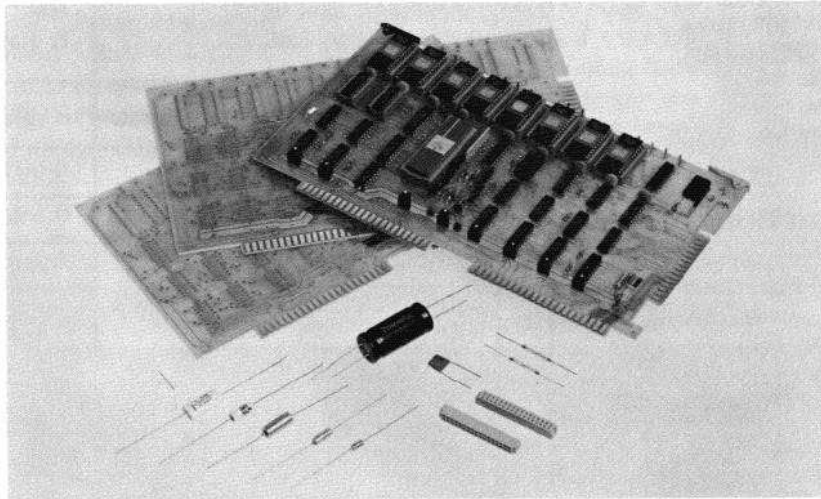

## ...In Semiconductor Process Evaluation

An automatic evaluation system for the semiconductor process is now possible with the 4140B. Static characteristics of diodes or FET's can be measured and plotted with 0.001 pA resolution. The threshold level can be obtained through data manipulation using the HP-IB interface. This is made possible by the high speed data output (at 4 ms maximum rate) to the HP-IB Bus.

By adding the 4275A Multi-Frequency LCR Meter, a complete evaluation of the semiconductor process can be made to 10 MHz. This includes high frequency C-V measurements, doping profiles and the analysis of minority carrier lifetimes.

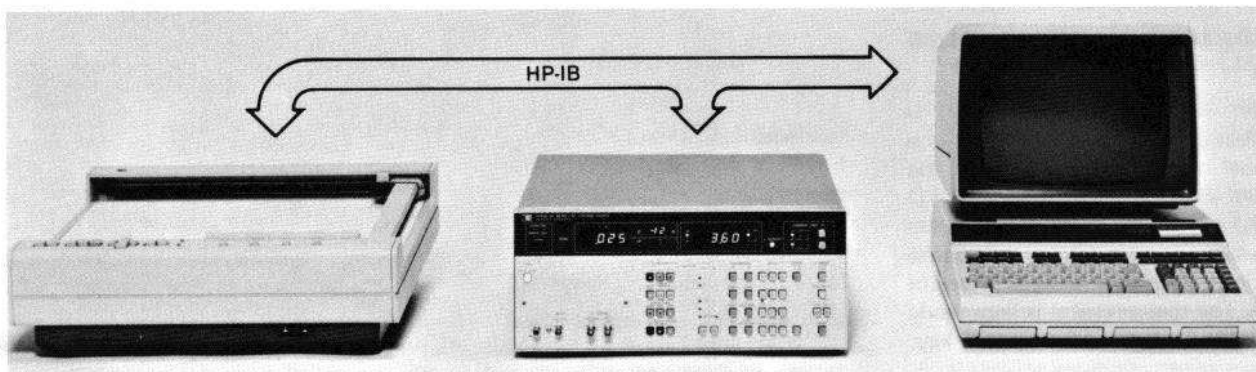
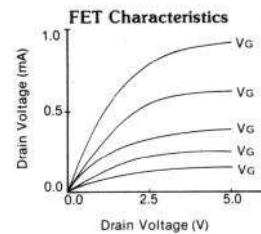

# Improved Reliability and Efficiency...

## ...In Evaluating Semiconductor Devices

The 4140B pA Meter/DC Voltage Source offers outstanding flexibility in the measurement of semiconductor devices. The capability of making current (I), current-voltage (I-V) and capacitance-voltage (C-V) measurements using the internal dc sources is standard in the 4140B. These measurements are made possible by internal ramp voltages, current ranges from  $\pm 1.000$  pA to  $\pm 10$  mA full scale with 0.5% basic accuracy and an auto/manual voltage sweep mode.

These features enable the user to obtain faster, more accurate results in semiconductor device testing and to increase his yield by prompt, flexible process evaluation.

### Typical Applications:

- Quasi-static C-V characteristics
- Threshold voltage and static characteristics of FET's
- DC parameters of IC's
- Light/dark current of optical devices
- Electron beam secondary electron measurement

### Types of Devices:

- Optical devices (photo transistor, photo isolator...)
- IC's (logic, memory, linear...)
- Diodes, FET's
- MIS construction, P/N junction

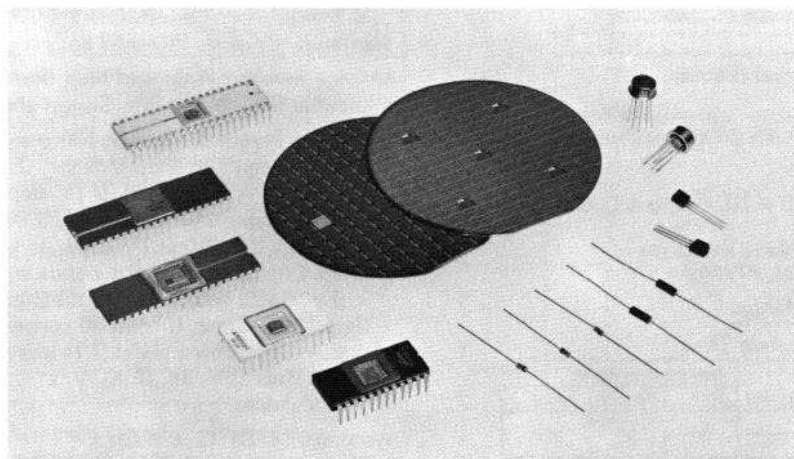

## ...In the Evaluation of Insulation Materials

Resistance values of approximately 0.5 ohms to  $10^{17}$  ohms can be calculated from the applied voltage and measured current values. The hold and step delay timer functions allow the user to easily determine the one minute resistance value of a material. The analysis of polarization/absorption phenomena of insulating materials can also be accomplished with the 4140B.

These measurements can make a major contribution to the reliability evaluation of many kinds of insulation materials.

### Typical Applications:

- Change of insulation resistance vs. temperature and humidity
- Analysis of Absorption/Polarization phenomena

### Types of Materials:

- Film (plastics, mylar, paper...)
- Liquid (insulation, varnish...)
- Solids (glass, ceramic, rubber...)
- Conductive rubber

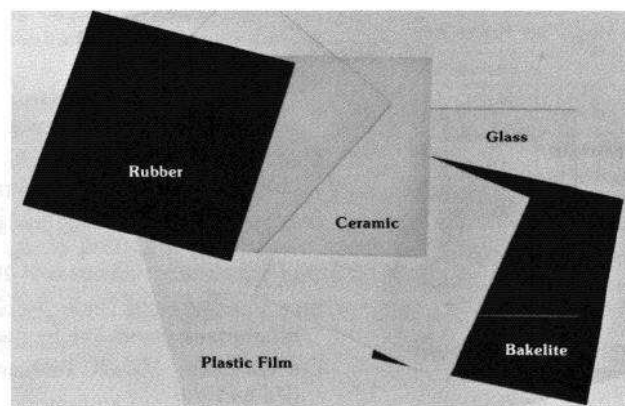

# Specifications

## 4140B Characteristics and Specifications

Measurement Functions: I, I-V and C-V

I (Current): Operates as independent picoammeter and programmable voltage sources

I-V (Current-Voltage): I-V characteristic measurements using the programmable staircase or linear ramp voltage source

C-V (Capacitance-Voltage): Quasi-static C-V characteristic measurement using the linear ramp source

Voltage Sources: Two separate sources (V<sub>A</sub> and V<sub>B</sub>)

V<sub>A</sub>: ±100 volt programmable source/function generator

V<sub>B</sub>: ±100 volt programmable DC voltage source

Measurement Function/Source Selection:

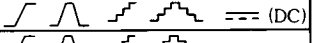
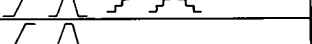
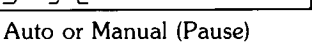
Function	V <sub>A</sub>	V <sub>B</sub>
I		--- (DC)
I-V		--- (DC)
C-V		---

Voltage Sweep: Auto or Manual (Pause)

### Current Measurements

Displays: Current, 3½ digits with 2 Digit Annunciator  
Voltage, 3½ digits

Measurement Range: ±1.000 x 10<sup>-12</sup>A to 1.000 x 10<sup>-2</sup>A  
full scale in 11 ranges

Overrange Capability: 100% on all ranges

Range Selection: Auto and Manual

Measurement Accuracy/Integration Time:

Range	Accuracy* ± (% of rdg. + counts)	Integration Time** (ms)		
		Short	Medium	Long
10 <sup>-2</sup> – 10 <sup>-9</sup>	0.5 + 2	20	80	320
10 <sup>-10</sup>	2 + 2			
10 <sup>-11</sup>	5 + 3	80	320	1280
10 <sup>-12</sup>	5 + 8	160	640	2560

\*Accuracy for long integration time with line filter on 23°C ±5°C, humidity ≤ 70%. For short and medium integration times, see Reference Data section.

\*\*Integration times specified at 50 Hz. For 60 Hz operation, multiply time by 5/6.

Voltage Burden: ≤ 10μV at full scale

Internal emf: ≤ 100 μV

Maximum Input (Peak Value):

Between Hi and Lo, ±2V on 10<sup>-2</sup> – 10<sup>-3</sup>A ranges

±30V on 10<sup>-4</sup> – 10<sup>-5</sup>A ranges

±120V on 10<sup>-6</sup> – 10<sup>-12</sup>A ranges

Between Lo and Guard, ±200V

Zero Offset: Cancels leakage current of test leads or test fixtures

Offset Range: 0 – ±100 x 10<sup>-15</sup>A

Trigger: INT, EXT and HOLD/MAN

Input Terminal: Triaxial

### Capacitance-Voltage (C-V) Measurement

**Note:** Capacitance is a calculated value derived from the following equation: C(F) = measured current value (A)/ramp rate (V/s)

Measurement Ranges: 0.0pF – 199.9pF and 200.0pF – 1999pF F.S. in two ranges

Ranging: Auto

% C: Capacitance change of device under test is displayed as a percent of the set value of the oxide capacitance (Cox = 100%)

% C Range: 0.0% – 199.9%

Cox Setting Ranges (2 ranges): 0.1pF – 199.9pF and 200pF – 1999pF

Capacitance Calculation Accuracy: Accuracy is dependent on accuracy of both the current measurement and ramp voltage. (See chart in reference data.)

Zero Offset: Cancels stray capacitances of test fixtures and test leads.

Offset Range: 0 – 100pF

High Speed I Data Output: Available with HP-IB interface. Outputs current measurement data at 4ms intervals (maximum rate). Refer to reference data for typical accuracies.

### DC Voltage Sources

Output Modes, V<sub>A</sub>:   
V<sub>B</sub>: ---

Voltage Ranges (V<sub>A</sub> and V<sub>B</sub>): 0 – ±10.00V and 0 ±100.0V in two ranges, auto range only.

Maximum Current: 10 mA, both sources.

Voltage Sweep: Auto and Man (Pause), up/down step in manual (Pause) mode. Sweep abort is standard

Operating Parameter Setting Ranges:

Start Voltage and Stop Voltage, 0 – ±10.00V, 0.01V steps; 0 – ±100.0V, 0.1V steps

Step Voltage, 0 – ±10.00V, 0.01V steps  
0 – ±100.0V, 0.1V steps

Hold Time, 0 – 199.9 seconds in 0.1s increments  
0 – 1999 seconds in 1.0s increments

Step Delay Time, 0 – 10.00 seconds in 0.01s increments  
0 – 100.0 seconds in 0.1s increments

Ramp Rate (dV/dt), 0.001V/s – 1.000V/s in 0.001V/s increments

Accuracy (at 23°C ±5°C):

Output Voltage, ±10V, ±(0.07% + 11mV)  
±100V, ±(0.09% + 110mV)

Ramp Rate\*,

±(0.2% + 10 μV/s) –  $\frac{0.00001 \times \text{Start Voltage (V)}}{\text{Hold Time} + 2\text{s}}$  ;

±(0.2% + 80 μV/s) –  $\frac{0.00001 \times \text{Start Voltage (V)}}{\text{Hold Time} + 2\text{s}}$  if

absolute value of start or stop voltage is > 10V.

\*Specified only when:

1. Temperature change is ≤ 3.6°C/hour
2. Time after start of ramp is ≥ 2 seconds

Ramp Linearity (%):

±(0.1 +  $\frac{0.0003 \text{ V/s}}{\text{Ramp Rate (V/s)}}$ ) –  $\frac{0.001 \times \text{Start Voltage (V)}}{\text{Ramp Rate (V/s)} \times (\text{Hold Time} + 2\text{s})}$  ;

±(0.2 +  $\frac{0.003 \text{ V/s}}{\text{Ramp Rate (V/s)}}$ ) –  $\frac{0.001 \times \text{Start Voltage (V)}}{\text{Ramp Rate (V/s)} \times (\text{Hold Time} + 2\text{s})}$  if  
absolute value of start or stop voltage is > 10V

Typical Values:

≤ 0.5%, 0 – ±10V

< 5% if absolute value of start or stop voltage is > 10V

Start/Stop Voltage (ramp only): ±20mV, (±200mV if absolute value of start or stop voltage is ≥ 10V)

Display of Output Voltage (ramp only): ±(0.05% of rdg. + 16mV), ±(0.09% of rdg. + 160mV) if absolute value of start or stop voltage is ≥ 10V

Step Voltage/Hold Time: Accuracy is dependent on accuracy of power line frequency (50 Hz or 60 Hz)

Current Limit: 100μA, 1mA and 10mA, ±10% (V<sub>A</sub> and V<sub>B</sub>)

Output Terminals: BNC; L-GND

# Reference Data

## Current Measurement<sup>1</sup>

### Current Measurement Accuracy\*

Range	Integration Time	
	Short	Medium
$10^{-2}$ - $10^{-9}$	0.5 + 4	0.5 + 3
$10^{-10}$	2 + 4	2 + 3
$10^{-11}$	5 + 8	5 + 4
$10^{-12}$	5 + 13	5 + 10

\*  $\pm$  (% of rdg. + counts), 23°C  $\pm$  5°C

### Current Ranging Times:

20 ms to 3.76 sec when ranging up. (3.76 sec is full ranging time from  $10^{-12}$  amp range to  $10^{-2}$  amp range.)

340 ms to 7.76 sec when ranging down. (7.76 sec is full ranging time from  $10^{-2}$  amp range to  $10^{-12}$  amp range.)

### Warmup Time: $\geq$ 1 hour

### Typical Response Times, 0-90% of Final Value:

Measurement Range (A)	Response Times		Measurement Range (A)	Response Times	
	*C = 2pF	C = 2nF		C = 2pF	C = 2nF
$10^{-2}$ thru $10^{-5}$	$\leq$ 1 ms	$\leq$ 1 ms	$10^{-10}$ and $10^{-11}$	$\leq$ 50 ms	$\leq$ 200 ms
$10^{-6}$ and $10^{-7}$	$\leq$ 3 ms	$\leq$ 3 ms	$10^{-12}$	$\leq$ 600 ms	$\leq$ 600 ms
$10^{-8}$ and $10^{-9}$	$\leq$ 15 ms	$\leq$ 15 ms			

\* C is the capacitance value of the test lead and/or fixture. 60 ms (50 Hz) or 50 ms (60 Hz) must be added when in FILTER ON mode.

### Common Mode Rejection Ratio: $\geq$ 120 dB ( $\leq$ 2 counts)

### Measurement Accuracy of High Speed I Data Output:

Range (A)	Accuracy (% rdg. + counts)
$10^{-2}$ thru $10^{-8}$	$\pm$ (0.5 + 6)
$10^{-9}$	$\pm$ (0.5 + 10)
$10^{-10}$	$\pm$ (2 + 10)
$10^{-11}$ and $10^{-12}$	$\pm$ (5 + 100)

### Capacitance Calculation Accuracy (% rdg. + counts):

Voltage Range (V)	Capacitance Range (pF)	Ramp Rate: dV/dt (V/s)		
		0.001 - 0.01	0.01 - 0.1	0.1 - 1
$\pm 10^*$	100.0	$\pm$ (6.2 + $\frac{0.08}{dV/dt}$ )	$\pm$ (5.3 + $\frac{0.3}{dV/dt}$ )	$\pm$ (2.2 + $\frac{2}{dV/dt}$ )
	1000	$\pm$ (6.2 + $\frac{0.03}{dV/dt}$ )	$\pm$ (2.3 + $\frac{0.2}{dV/dt}$ )	$\pm$ (0.7 + $\frac{2}{dV/dt}$ )
$\pm 100^{**}$	100.0	$\pm$ (13.2 + $\frac{0.08}{dV/dt}$ )	$\pm$ (6.0 + $\frac{0.3}{dV/dt}$ )	$\pm$ (2.3 + $\frac{2}{dV/dt}$ )
	1000	$\pm$ (13.2 + $\frac{0.03}{dV/dt}$ )	$\pm$ (3.0 + $\frac{0.2}{dV/dt}$ )	$\pm$ (0.8 + $\frac{2}{dV/dt}$ )

\* Start and stop voltages - 10V to +10V

\*\* Absolute value of start or stop voltages  $\geq$  10V

Note: Leakage current through resistance of DUT and test leads causes additional error.

### I-V and/or C-V Trigger Cycle (minimum values):

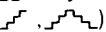
25ms ( $V_A$  Mode: )

50ms ( $V_A$  Mode: )

### Trigger (Minimum Triggering Interval)

Trigger	I Function	****High Speed I Data Output
INT	Approx. 200 ms	Approx. 10 ms*
EXT**	$\geq$ Integration Time	> 4 ms
MAN***	+ 3 ms	-

\* 50 Hz line frequency. For 60 Hz operation, multiply by 5/6.

\*\* External trigger from "1" state to "0" state > 1  $\mu$ s duration.

\*\*\* Triggered by front panel Ext/Man key.

\*\*\*\* Available only with HP-IB Interface

## DC Voltage Source

Output Resistance:  $\leq$  1 $\Omega$

Output Impedance:  $\leq$  1 $\Omega$  at 10 Hz,  $\leq$  100 $\Omega$  at 100 Hz

Programming Speed: For (  ): Approx. 2.5 ms (1V/ms slew rate)

Ranging: Approx. 30 ms

### CURRENT MEASUREMENT WITH STAIRCASE VOLTAGE (I and I-V FUNCTIONS)

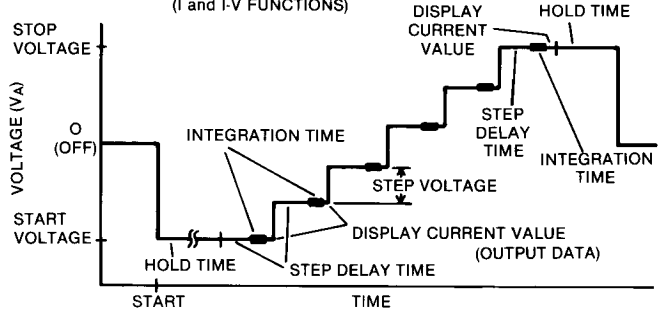

### CURRENT MEASUREMENT WITH RAMP VOLTAGE (I, I-V AND C-V FUNCTIONS)

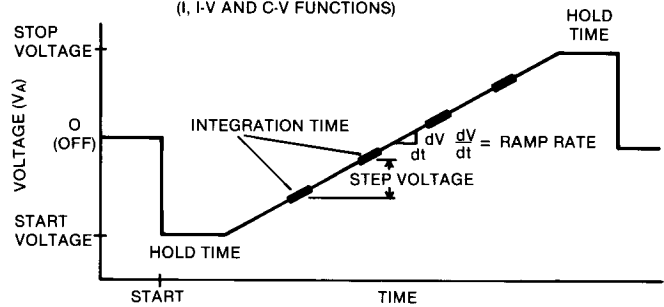

## Analog Output (I, C and $V_A$ )

### Output Voltages:

Output	Data Range	Output Voltage	Resolution
$V_A$	0 - $\pm$ 10V	0 - $\pm$ 1.000V	1 mV/count
	$\pm$ 10.1 - $\pm$ 100V	$\pm$ 1.01 - $\pm$ 10.00V	10 mV/count
I	Full Scale	$\pm$ 5.000V	5 mV/count
C	100 pF	0.5V	0.5 mV/count
	1000 pF	5V	5 mV/count
	100% (% Display)	5V	5 mV/count

Accuracy:  $\pm$  (0.5% + 20 mV)

Low Pass Filter: 3 position: OFF, 0.22s  $\pm$  20% and 1s  $\pm$  20% applied to both  $V_A$  and I/C data outputs

Pen Lift Output: TTL Low Level ( $\leq$  0.8V) during sweep period in I-V and C-V functions

Recorder Output Scaling: Pushbutton scaling of lower left and upper right limits of X-Y recorder

Pushbutton	$V_A$ Output	I/C Output*
L.L. (Lower Left)	Minimum voltage value of start or stop voltages	Full scale value of minus (-) output voltage Zero (0) volts for C-V measurement function
Zero	0V	0V
U.R. (Upper Right)	Maximum voltage value of start or stop voltages	Full scale value of plus (+) output voltage (e.g., +5V for I full scale value).

\* See output voltage for each function in preceding chart

<sup>1</sup> Allowable max source capacitance  $\leq$  2000 pf for current measurements.

## HP-IB Interface\*

HP-IB Interface Functions:

SH1: Source Handshake Capability

AH1: Acceptor Handshake Capability

T5: Talker Capabilities of Basic Talker, Serial Poll and Unaddress if MLA

L4: Listener Capabilities of Basic Listener and Unaddress

SR1: Service Request Capability

RL1: Remote/Local Capability

DC1: Device Clear Capability

DT1: Device Trigger Capability

Remote Controlled Functions: Measurement function, current range, integration time, I data output trigger, voltage sweep controls, current limit,  $V_A$  and  $V_B$  voltages, zero (offset), self test and parameter settings (voltages, sweep/hold/delay times)

Data Output: Measured Data (I, C and  $V_A$ )

Voltage Settings ( $V_A$  and  $V_B$ )

Parameter Settings

Set Value of Cox

Front Panel Key Status

\*IEEE 488-1975 ANSI STD #MC1.1

## General Information

**Operating Temperature:** 0°C to 40°C

**Relative Humidity:** ≤ 70% at 40°C

**Power:** 100, 120, 220V ± 10%, 240V +5% - 10%;  
48-66 Hz, 135VA maximum with any option

**Dimensions:** 426 mmW x 177 mmH x 498 mmD  
(16.5" x 7" x 19.6")

**Weight:** 14.4 kg (31.7 lbs.)

**Accessory Furnished:** 16053A Test Leads and 16055A Test Fixture

## Accessories Furnished

**16053A Test Leads:** Consists of one tri-axial cable, two each BNC-BNC cables and one connection plate with mating female panel-mount connectors (P/N 16053-61001). Cables are one meter in length. The 16053A is useful for connecting to prober or user designed test fixtures.



**16055A Test Fixture:** For general device measurements Provides electrostatic and light shielding for stable pA current measurements. Consists of test fixture, two connection plates (one for clip leads and one for T-05 10 pin sockets) to allow easy connection to devices under test. Also furnished is a kit containing one each 8, 10, and 12 pin socket, 10 each clip leads, and 10 each connection leads for TO-5 sockets.

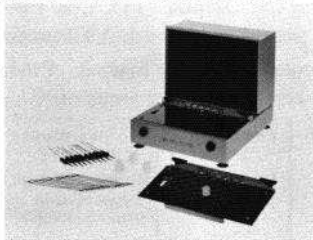

## Accessories Available

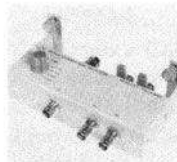

**16054A Connection Selector:** Provides a simple method to select appropriate connection of low lead for the pA meter section. Use in conjunction with the 16053A. Cannot be used with 16055A Test Fixture.



**16056A Current Divider (10:1):** For use only on the 10 mA range to extend the measurement capability to 100 mA.

## Available Accessories/Recommended Parts

Description	HP Part/Model #
HP-IB Cable 0.5m	10631D
1.0m	10631A
2.0m	10631B
3.0m	10631C
Triaxial Connectors	
Female	1250-0687
Male	1250-1413
	16053-24001
	16053-24002
BNC Connectors	
Female	1250-1279
Male	1250-0408
16055A Accessories	
Connection plate for clip leads	16055-65001
Connection plate with TO-5 socket (10 pin)	16055-65002
Clip leads (5 each)	16055-65003
Connection leads for TO-5 socket (5 each)	16055-65004
TO-5 socket (8 pins)	1200-0238
TO-5 socket (10 pins)	1200-0239
TO-5 socket (12 pins)	1200-0240
Triaxial cable (1m)	16053-61002
BNC-BNC cable (1m)	16053-61003
Connection plate for 16053A	16053-61001

## Ordering Information

4140B pA Meter/DC Voltage Source

### Options

Option 907 Front Handle Kit (P/N 5061-0090)

Option 908 Rack Flange Kit (P/N 5061-0078)

Option 090 Rack and Handle Kit (P/N 5061-0084)

Option 910 Extra Manual

### Accessories

16054A Connection Selector

16056A Current Divider (10:1)

For more information, call your local HP sales office listed in the telephone directory white pages. Ask for the Electronic Instruments Department. Or write to Hewlett-Packard: **U.S.A.:** P.O. Box 10301, Palo Alto, CA 94303-0890. **Europe:** P.O. Box 999, 1180 AZ Amstelveen, The Netherlands. **Canada:** 6877 Goreway Drive, Mississauga, L4V 1M8, Ontario. **Japan:** Yokogawa-Hewlett-Packard Ltd., 3-29-21, Takaido-Higashi, Suginami-ku, Tokyo 168. Elsewhere in the world, write to Hewlett-Packard Intercontinental, 3495 Deer Creek Road, Palo Alto, CA 94304.