

HP 4145B Semiconductor Parameter Analyzer

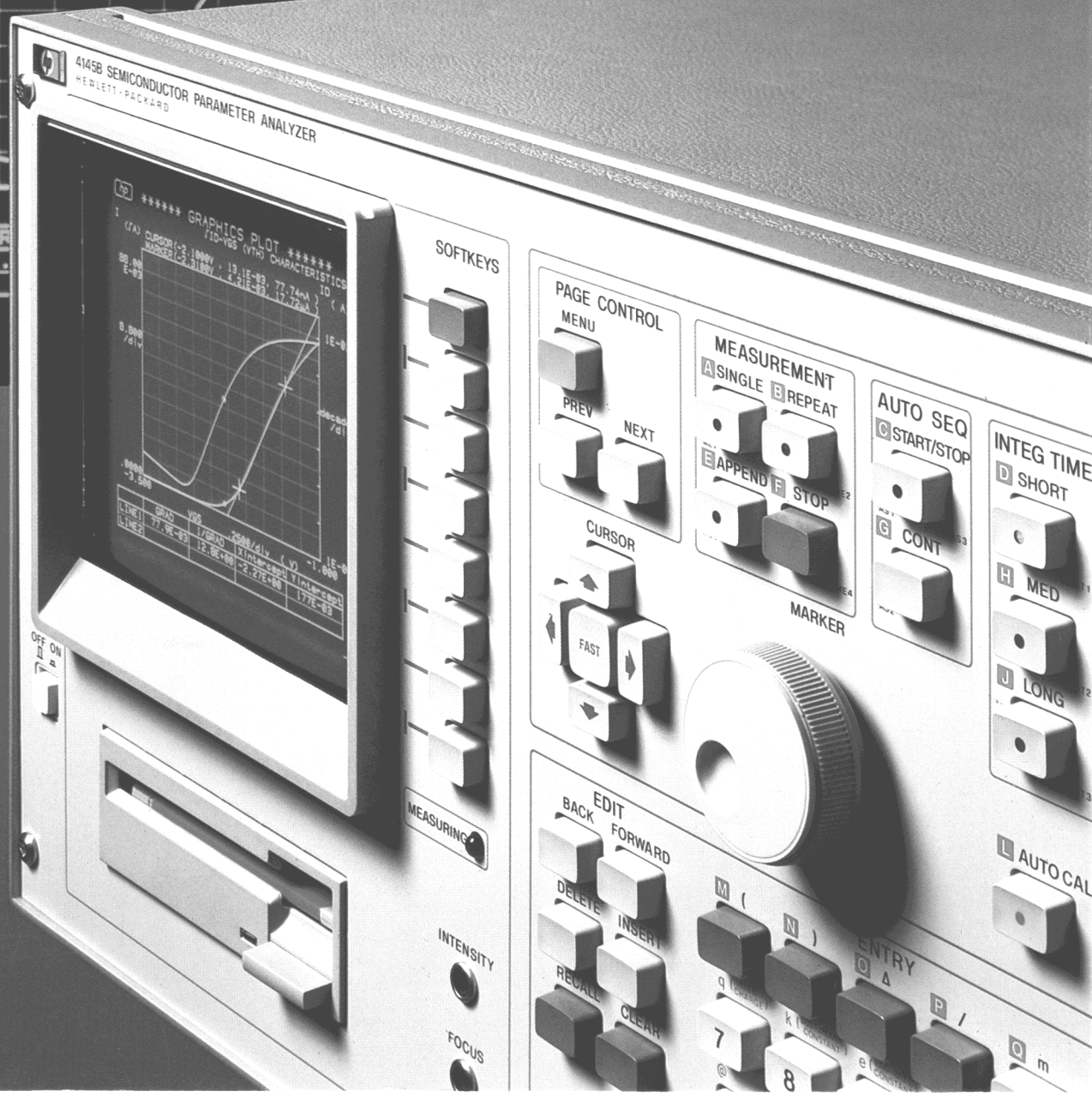

Improve Your Designs and Processes with Automatic Analysis of Semiconductor Parameters

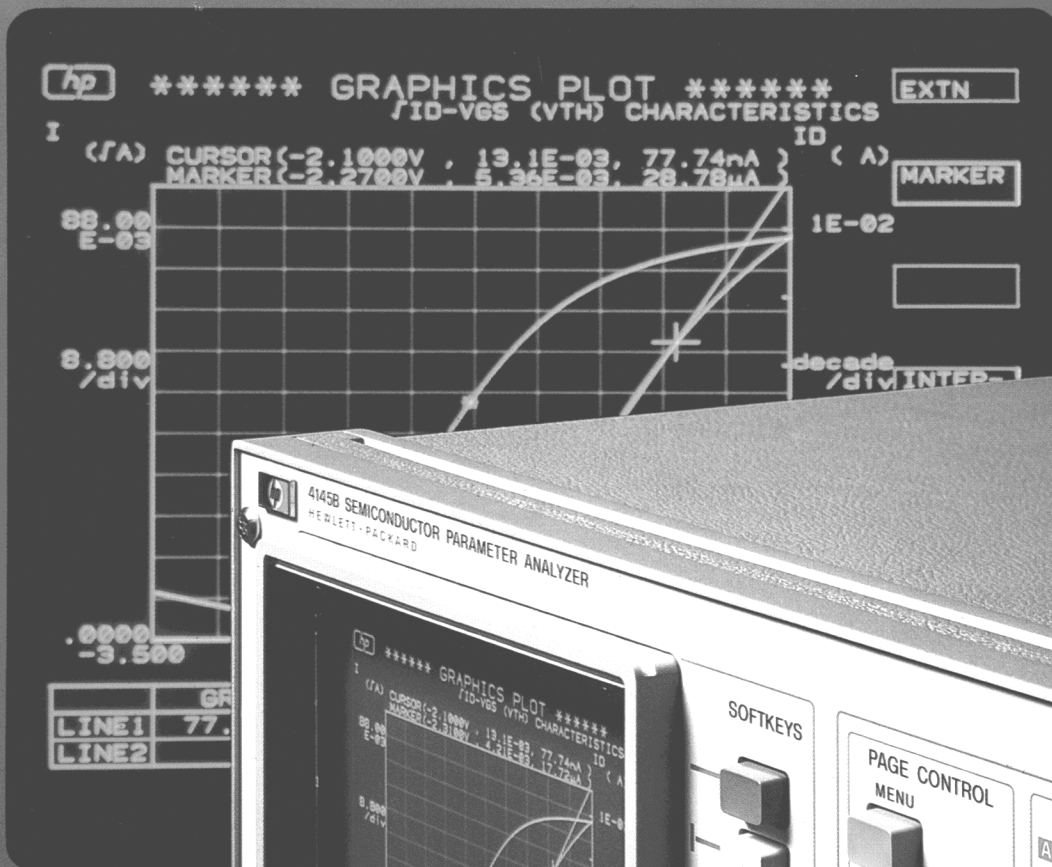



Perfect Your IC Designs in R&D

Decrease Semiconductor Development Time

- Develop Semiconductor Technology
- Evaluate New Materials
- Develop Semiconductors for Production



Assure Process Quality in Manufacturing

Improve IC Yields

- Verify the Quality of Your Process
- Design and Control New Semiconductor Processes



Analyze Components Used in Your Circuits

Quickly Evaluate Semiconductor Performance

- Make Go/No Go Tests at Incoming Inspection
- Evaluate Semiconductors in Circuit Design Lab
- Solve Semiconductor-related Production Problems

HP 4145B Semiconductor Parameter Analyzer

Set up measurements quickly and analyze results fast with SOFTKEYS and PAGE CONTROL.

Save time with this interactive CRT Display. Display formats include graphics, list, matrix, schmoo and time domain.

Analyze data stored on the internal disc with any HP 9000 Series 200/300 computer. Disc drive uses standard HP 3.5 inch discs. Store up to 240 measurement programs or 105 data files on a single microfloppy.

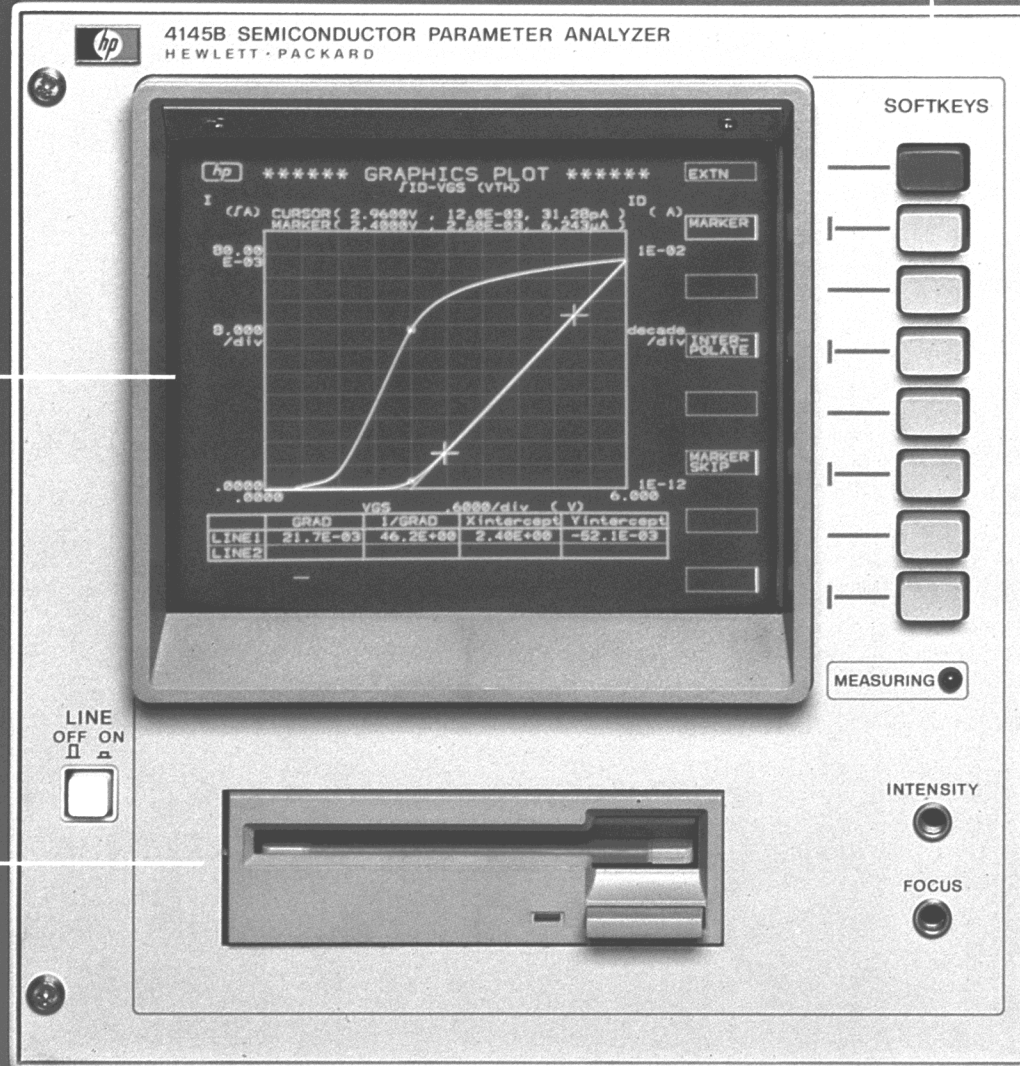

uctor

Compare multiple measurements on the display by using the APPEND key. APPEND retains up to 1140 data points. You can also execute single or repetitive measurements with up to 1024 points.

Automate your bench-top measurements easily. Use the HP 4145B's Auto Sequence Programming to control the analyzer's measurement, data storage, and plotting functions without using a computer.

Print data or plot graphics without using an HP-IB controller. Printers and plotters that have a LISTEN ONLY or LISTEN ALWAYS mode can be used.

Optimize measurement speed and measurement accuracy with selectable Integration Time and Auto Calibration.



Improve Your Device Quality

The HP 4145B performs fast, accurate analysis of semiconductor devices to increase your productivity and improve your device quality. You can stimulate and measure voltage and current sensitive devices easily with the four Source Monitor Units (SMUs). And to help you analyze data, the HP 4145B computes dc parameters like h_{FE} and g_m for you.

The HP 4145B's versatile SMU-based architecture saves you valuable time and eliminates measurement instabilities caused by changing DUT connections. Each SMU can alternately act as a voltage source/current monitor or current source/voltage monitor. You can characterize a four-terminal device completely without changing device connections - simply change the SMU's current/voltage operating mode.

Increase Productivity on the Bench or in a System

You can produce results from the start with the HP 4145B. Use the powerful front panel keys for control and analysis in stand-alone bench-top applications. Or use the HP 4145B's Auto Sequence Programming to control measurements, data storage, and plotting functions without using a computer. And, since the HP 4145B is completely programmable, you can easily incorporate it into an automatic test system to increase your test throughput.

Shorten Your Design and Analysis Times

The HP 4145B automates tedious data gathering during device characterization. When design changes are made, you can evaluate them quickly and efficiently, minimizing project delays and cost overruns.

At the touch of a button, the HP 4145B can position cursors and lines on the display, giving you direct readout of dc parameters like Early voltage and threshold voltage. You can position a marker anywhere on the curve and read out coordinates directly. Or zero in fast with "auto scale", "zoom" and "move window" commands.

HP 4145B Key Performance Features

Source Monitor Unit (SMU)

The HP 4145B provides you with four SMUs. Each SMU can be used as a voltage source/current monitor or as a current source/voltage monitor.

SMU Range:

V: ± 1 mVdc to ± 100.00 Vdc

I: ± 1 pAdc to ± 100.0 mAdc

(± 50 fA resolution in current monitor mode)

Accuracy:

V: $\pm 0.15\%$ to $\pm (0.15\% + 40$ mV)

I: $\pm 0.4\%$ to $\pm 1.8\%$

Measurement Speed

Make up to 150 measurements per second.

Voltage Monitor (V_M)

Two voltage monitors are built into the HP 4145B in addition to the SMUs.

Measuring Ranges: ± 20.000 Vdc and ± 2.0000 Vdc

Accuracy: $\pm 0.5\%$ (20V range) and $\pm 0.2\%$ (2V range)

Resolution: ± 1 mV (20V range) and ± 100 μ V (2V range)

Voltage Source (V_S)

Two voltage sources are available in addition to the SMUs.

Output Range: ± 20.000 Vdc

Accuracy: $\pm 0.5\%$

Completely Evaluate Your Semiconductor Devices

The HP 4145B excels in both TEG (Test Element Group) measurements performed on semiconductor wafers and in parameter extraction of simulation models in computer-aided design applications. You can also use the HP 4145B to characterize packaged devices with the supplied HP 16058A Test Fixture.

Applications include dc characterization of these semiconductors:

- Bipolar Transistors
- MOS structures, Junction FETs, GaAs FETs
- Semiconductor Diodes
- Photoelectric conversion devices (Photodiodes, Phototransistors)
- Light Emitting Devices (LEDs, GaAs Infrared Emitting Diodes)
- Operational Amplifiers
- Gated Diodes
- Static Electricity Induced Transistors (SITs)

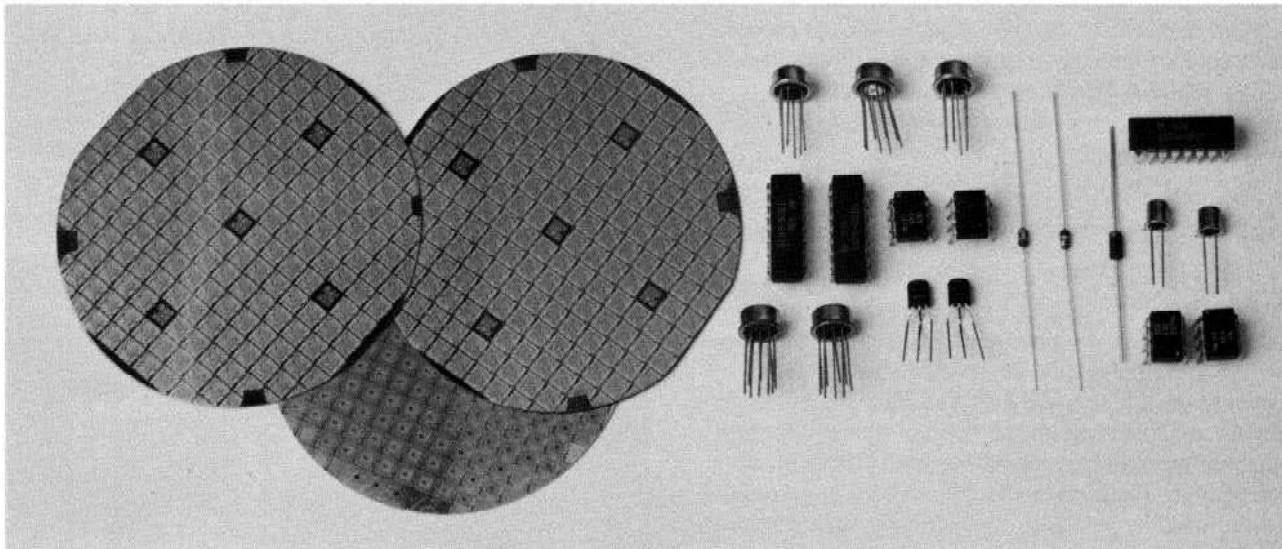

Easily Characterize Both Wafers and Packaged Devices

MOS Structure Parameter Analysis

Theoretical threshold voltage is a dc parameter of great significance. The HP 4145B reduces the time required to obtain this parameter. The example CRT display shows FET $\sqrt{I_D} - V_{GS}$ and $\log I_D - V_{GS}$ on a plot with double Y axes.

Using the $\sqrt{I_D} - V_{GS}$ plot and LINE function, you can read theoretical $V_{GS(th)}$ (X-intercept) as 2.40 volts. $I_{D(th)}$ is also read directly (marker readout) as $6.243 \mu A$. You can perform this complete measurement and graphic analysis in less than two minutes.

Use the $\log I_D - V_{GS}$ plot to obtain V_{GS} values at specific values of I_D . You can read V_{GS} values in numeric form with the HP 4145B's marker and interpolation functions.

Parameters which can be analyzed include:

- Threshold Voltage Bulk Potential Dependency
- Extrapolated Threshold Voltage
- Gain Factor (K) in Saturated/Non-Saturated Regions
- Mutual Conductance Drain and Gate Voltage Dependency

- Body Factor Effect Multiplication Factor (M)
- Punch-Through Voltage
- PN Junction Break-Down Voltage
- Channel Conductance-Gate Voltage Characteristics

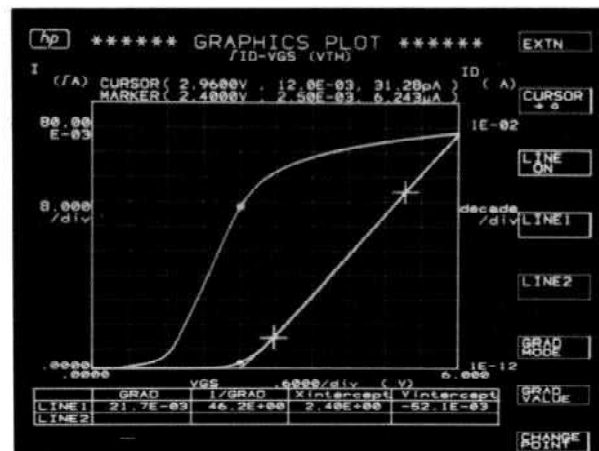

Direct Readout of Threshold Voltage Speeds MOS Analysis

Increase Your Efficiency During Research and Development of New Materials

The HP 4145B provides your research lab with capabilities that will meet dc characterization requirements for present devices, and also provides you with functions needed for development of new materials.

The HP 4145B features eight different analysis methods. You can make readings using contactline, gradient, comparison, zoom and marker methods. The calculation function has 11 arithmetic functions including LOG, EXP and Δ (differential

calculation). You can also use two user-defined functions.

New materials which can be analyzed include:

- Gallium Arsenide Devices
- Liquid Crystal Structures
- Ceramic Semiconductors
- Amorphous Silicon Devices
- Solar Cell Elements
- Solar Cell Arrays

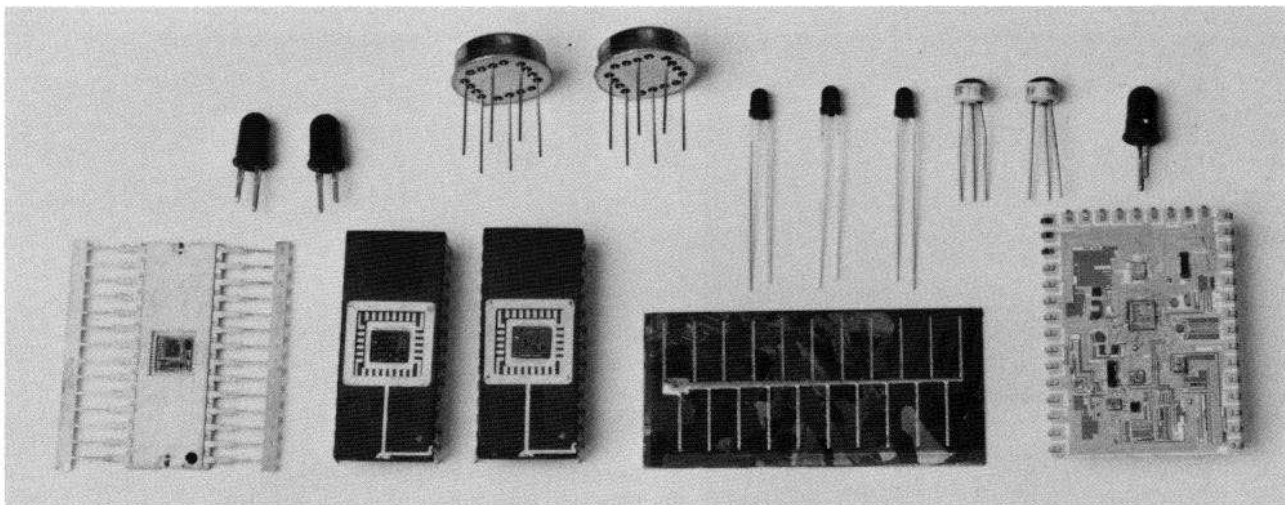

Shorten Analysis Times on Devices From Si to GaAs

Bipolar Device Parameter Analysis

The HP 4145B is a valuable tool in bipolar integrated circuit design. You can simultaneously measure $I_C - V_{BE}$ and $I_B - V_{BE}$. After each measurement, the HP 4145B automatically computes and plots h_{FE} vs. I_C on a log-log scale.

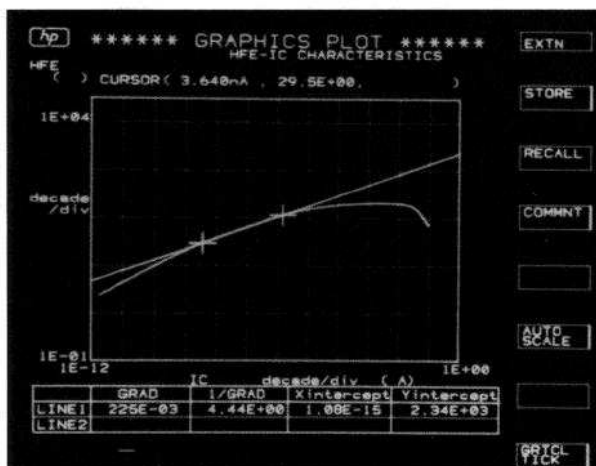

Quickly Extract Parameters for the Gummel-Poon Model

To analyze this data, you can position a straight line tangent to any point along the $h_{FE} - I_C$ curve. Once the line is positioned, you can read slope and X intercept values directly on the CRT. Next, by performing a parallel shift on the tangent line, you can obtain numeric values of knee current (I_K) and maximum value of h_{FE} (β_{FM}) directly on the CRT. These are parameters of the Gummel-Poon Model. Parameters which can be analyzed include:

- DC Current Gain (h_{FE} , h_{FB}) - Collector Current Characteristics
- Evaluation of Surface Recombination Current as Related to PN Junction Forward Bias Characteristics
- Evaluation of Current Generation as Related to PN Junction Reverse Bias Characteristics
- Breakdown Voltage (BV_{EBO} , BV_{CBO} , BV_{CEO} , BV_{CSO})
- Sheet Resistance
- Resistivity
- Collector-Emitter and Emitter-Base Saturation Voltage
- Collector Cut-Off Current (I_{CBO} , I_{EBO})

Automate Your Bench-Top Evaluation Procedures

You can program the HP 4145B to perform sequential measurements and output the results. The AUTO SEQUENCE SETUP (shown at the right) is an automated procedure for characterization of I_C , I_B - V_{BE} , h_{FE} - I_C , collector current-voltage and $V_{CE(SAT)}$ of a bipolar transistor.

The auto sequence program initiates a measurement sequence, activates the plotter/printer for hard copy results and then stores measurement data in disc memory. Hard copy output is shown below.

[hp] *** AUTO SEQUENCE SET UP ***

- | | | |
|-----------|------------------------|--|
| 1 GET P | ICBVBE | Call up program from disc |
| 2 SINGLE | | Single Sweep |
| 3 PLOT | 100, 3600, 3500, 7000 | Output CRT display contents to plotter |
| 4 SAVE D | ICBVBE | Save test results on disc |
| 5 GET P | HFE1 | |
| 6 SINGLE | | |
| 7 PLOT | 100, 100, 3500, 3500 | Allows viewing of results before output to plotter |
| 8 GET P | NPN1 | |
| 9 SINGLE | | |
| 10 PAUSE | | |
| 11 PLOT | 3600, 3600, 7000, 7000 | |
| 12 GET P | VCEsat | |
| 13 SINGLE | | |
| 14 PLOT | 3600, 100, 7000, 3500 | Advance plotter page |
| 15 PAGE | | |
| 16 WAIT | 60 | Wait time before execution of next command |
| 17 PRINT | | |

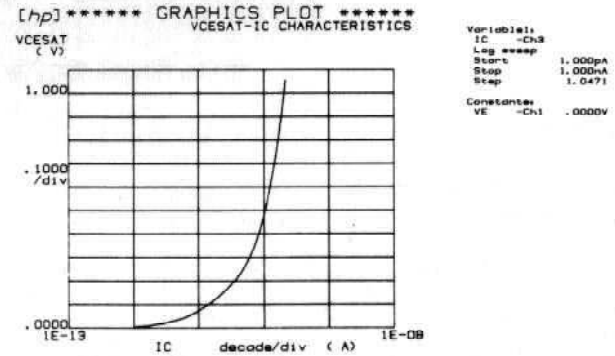
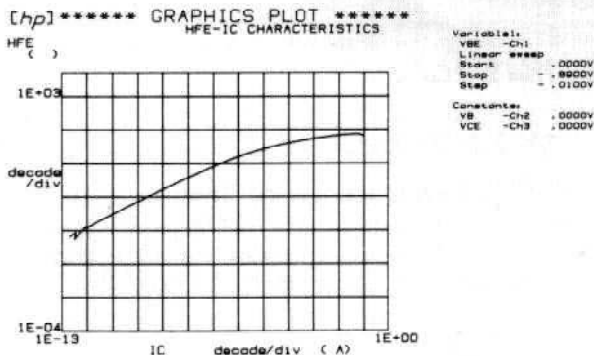
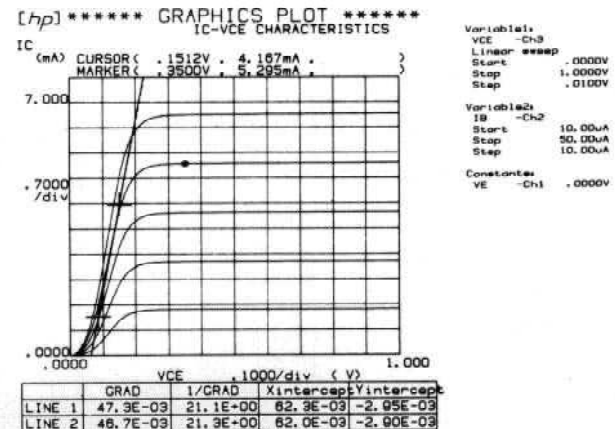
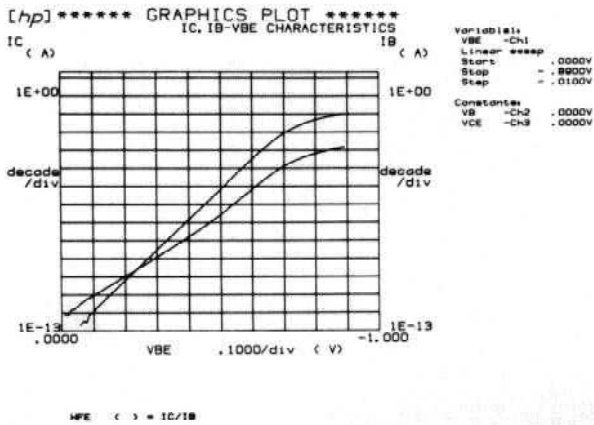

Store Your Programs and Data on Flexible Discs

The HP 4145B uses double-sided, double-density microfloppy discs to store measurement data and programs. The furnished system disc contains the HP 4145B's operating system. Load the operating system into memory at power-on, then use any initialized disc to store your data. You can initialize discs and copy the operating system with the HP 4145B or an HP 9000 Series 200/300 computer.

Use any standard HP 3.5 inch disc such as the HP 92192A. Each disc stores up to 630 Kbytes of information. Store approximately 240 programs or 105 data files on a single disc.



Analyze Your Data with an HP 9000 Series 200/300 Computer

Select From Five Different Display Modes to Suit Your Evaluation Purpose

You can use the **Schmoo Plot** for map-type displays when analyzing characteristics affected by two independent variables. Each characteristic value is represented by one of five different symbols. You can highlight a single symbol and display its numeric value with the cursor.

The **Matrix Display** is a numeric display of a characteristic affected by two variable parameters. Rows are formed by up to 1024 VAR 1 values. Columns are formed by up to 6 VAR 2 values. Matrix elements can be measured values or functions of VAR 1 and VAR 2.

The **List Display** shows you all measurement conditions, values and calculations in a list format.

You can analyze semiconductor parameters changing as a function of time in the **Time Domain**. Make measurements up to 85 minutes with a minimum interval of 10 ms. Use the graphic, matrix or list display modes.

Use the **Graphic Display** for simultaneous display of two characteristics using double-axis format. The Graphic Display gives you a quick grasp of overall device characteristics.

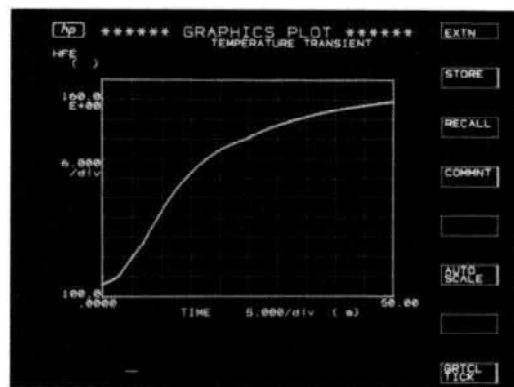
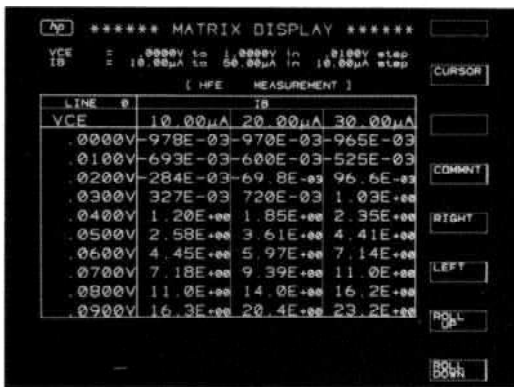
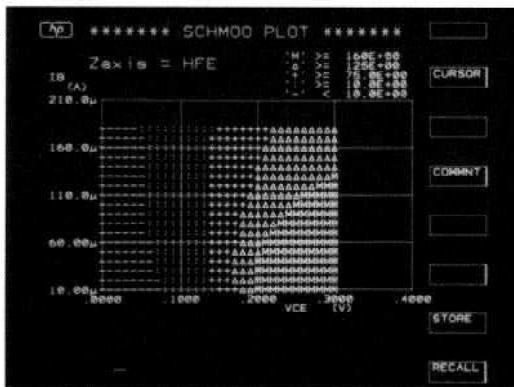

User Functions Can Calculate $h_{FE} = \frac{I_C}{I_B}$ and $I = I_0 e^{(qV/KT)}$

The HP 4145B provides you with two User Functions in which 11 front-panel arithmetic operators may be used. Values of User Functions are computed simultaneous with each measurement and displayed in the same manner as a measurement value.

The most common constants used in semiconductor analysis are also available on front-panel keys (K: Boltzmann constant; q: electron charge; e: dielectric constant of a vacuum).

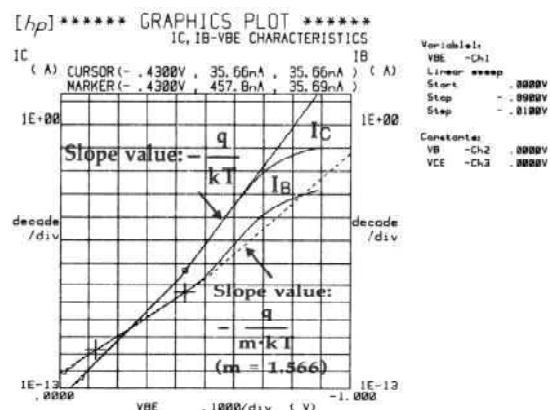

Easy-To-Use Menu and Page Format

The PREV, NEXT and MENU keys make operation as simple as turning the pages of a book. Measurement setup can also be controlled by operating the SOFTKEYS.



Fill-in-the-Blank Programming

To program measurement setups simply key data into the blanks indicated by the display pointer (▶). After your program is completed, you can store it on the disc.



Eight Functions Give You Complete Analysis of Test Results

- Marker gives digital readout anywhere on curve.
- Cursor gives numeric readout anywhere on CRT.
- Line shows direct readout of slope (gradient) plus X and Y intercepts.
- Line Control changes line position.
- Auto Retrieve displays measurement data in a different format.
- STORE and RECALL provide comparison functions using an Overlay Display or Double-Axis format.
- Auto Scale optimizes graphic scaling.
- Zoom Function expands or contracts the graphics plot.

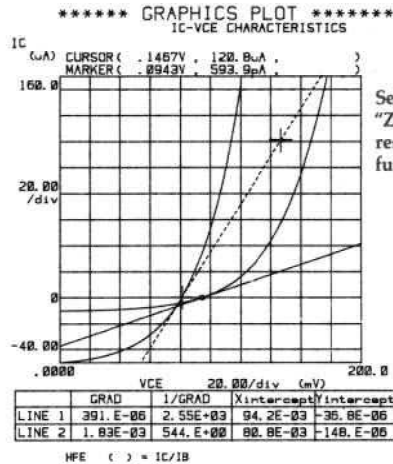

Selected area of a curve is "ZOOMED" to increase resolution. Also LINE function is used for analysis.

SMUs (Source Monitor Units) Provide Reliable Measurements

With the HP 4145B's SMU architecture, you can make a complete set of dc semiconductor wafer measurements with one probing. This eliminates instabilities caused by changing connections at the DUT and adds up to highly reliable measurements.

The accompanying diagram shows four SMUs connected to a Field-Effect-Transistor (FET). In a drain current vs. drain voltage characteristics measurement, you set all SMUs in the voltage source/current monitor mode. SMU1 and SMU2 operate as swept voltage sources. SMU2 monitors drain current. After completing this test, you can measure breakdown voltage. Simply change SMU2 to operate as a current source/voltage monitor and measure the breakdown voltage at the desired constant current.

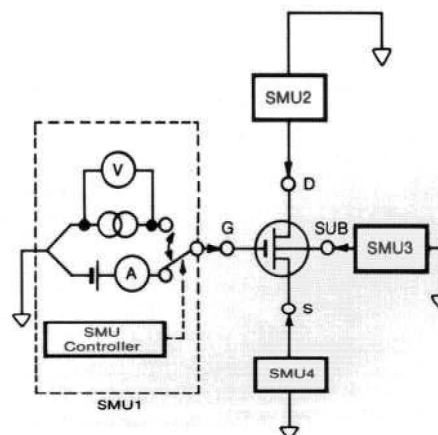

System Expansion is Easy with HP-IB

The HP 4145B easily interfaces with other instrumentation and controllers to construct a process evaluation system that best suits your needs. The accompanying diagram shows a complete semiconductor evaluation system.

You can combine the HP 4145B and HP 4085M Switching Matrix to make 1 pA and 1 mV resolution measurements at any of 48 DUT pins. Add the HP 4280A 1 MHz C Meter/C-V Plotter to make C-V and C-t measurements with 1 fF capacitance

resolution. And the HP 4140B pA Meter gives you current resolution down to 1 fA.

The powerful HP 9000 Series 300 Technical Computer controls the system. You can make high quality plots with the plotter including direct dumps of the HP 4145B's display.

HP-IB is an implementation of IEEE-488 and ANSI-MC 1.1 standards.

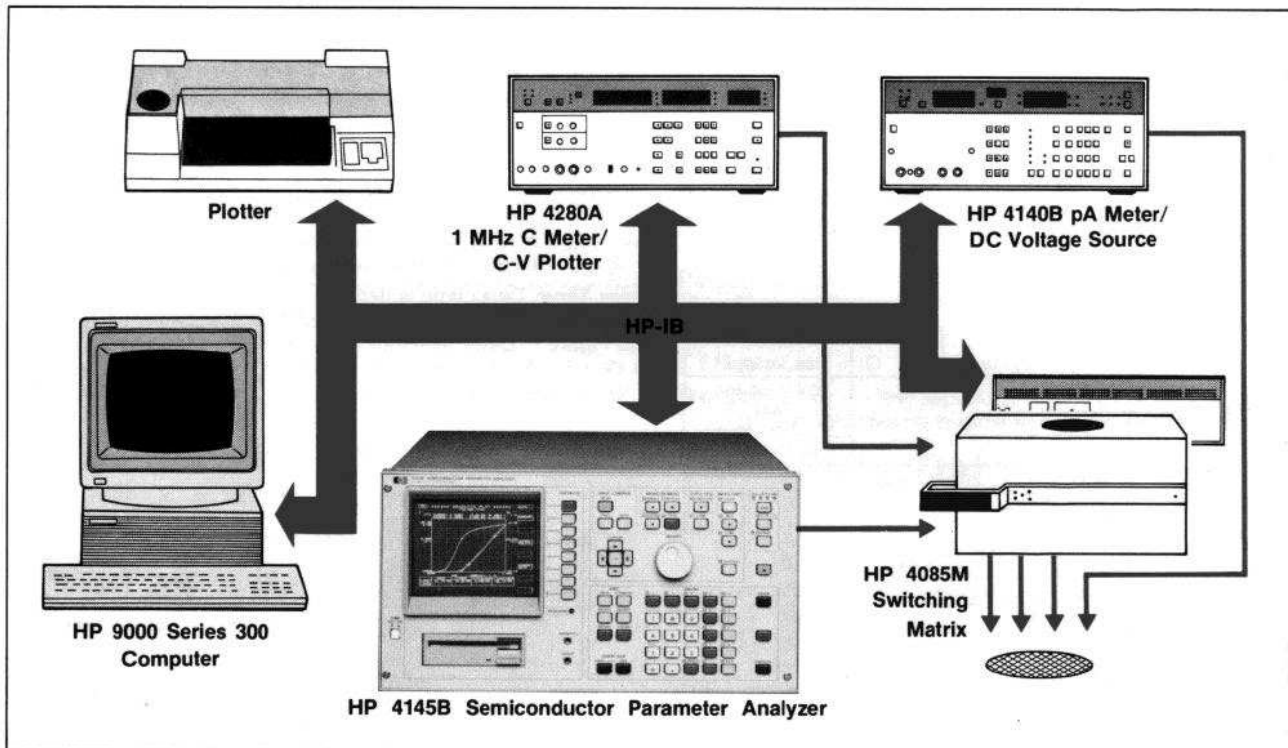

Expand Your Measurement Capabilities with this Semiconductor Parameter Evaluation System

Accurately Measure Wafers and Packaged Devices

You can connect the HP 4145B to a wafer prober and test devices in the wafer stage. After a device is packaged, use the supplied HP 16058A test fixture. The HP 16058A includes seven plug-in test modules for testing many different packages. Shown here are the HP 16058A Test Fixture plus a supplied connector plate for adapting to prober shield boxes.

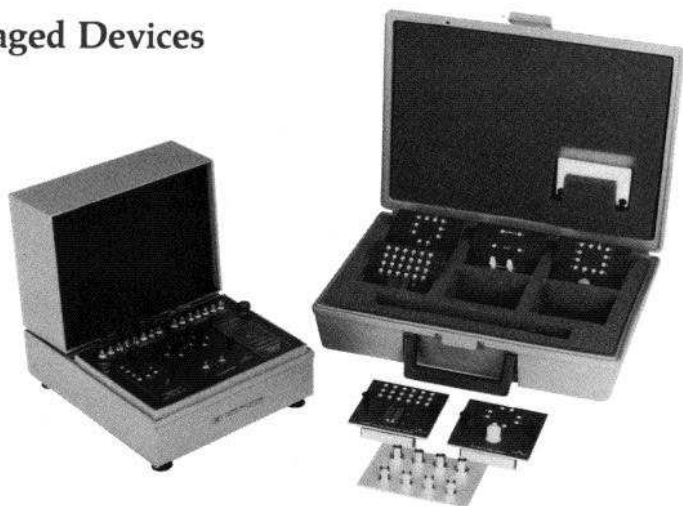

Specifications

MEASUREMENT

Source Monitor Unit (SMU) Characteristics

Each SMU can be programmed to source voltage and monitor current, or conversely to source current and monitor voltage. Tables 1 and 2 specify both the measuring and sourcing parameters.

Each SMU can also be programmed to COM mode. This sets voltage at 0 volts and current compliance limit at 105 mA. See "Reference Data" section on page 13 for more information on SMUs.

SMU output/measurement resolution: dc volts = 4-1/2 digits, dc current = 4 digits. See Tables 1 and 2 for details.

Voltage measurement input resistance/current source output resistance: $\geq 10^{12}\Omega$

Voltage source output resistance/current measurement input resistance: 0.4Ω .

Maximum capacitive load: 1000 pF

Table 1
SMU Voltage Range, Resolution and Accuracy

Voltage Range	Resolution	Accuracy ^{1,2}	Max. Current ³
$\pm 20V$	1 mV	$\pm(0.1\% + 10 \text{ mV} + 0.4 \times I_{out}^*)$	100 mA
$\pm 40V$	2 mV	$\pm(0.1\% + 20 \text{ mV} + 0.4 \times I_{out})$	50 mA
$\pm 100V$	5 mV	$\pm(0.1\% + 50 \text{ mV} + 0.4 \times I_{out})$	20 mA

* I_{out} is SMU output current in amps.

Table 2
SMU Current Range, Resolution and Accuracy

Current Range	Resolution	Accuracy ^{1,2}	Max. Voltage ⁴
$\pm 100 \text{ mA}$	$100 \mu\text{A}$	$\pm(0.3\% + 100 \mu\text{A} + 2\mu\text{A} \times V_{out}^*)$	20V ($I > 50 \text{ mA}$) 40V ($20 \text{ mA} < I < 50 \text{ mA}$) 100V ($I < 20 \text{ mA}$)
$\pm 10 \text{ mA}$	$10 \mu\text{A}$	$\pm(0.3\% + 10 \mu\text{A} + 200 \text{ nA} \times V_{out})$	100V
$\pm 1000 \mu\text{A}$	$1 \mu\text{A}$	$\pm(0.3\% + 1 \mu\text{A} + 20 \text{ nA} \times V_{out})$	
$\pm 100 \mu\text{A}$	100 nA	$\pm(0.3\% + 100 \text{ nA} + 2 \text{ nA} \times V_{out})$	
$\pm 10 \mu\text{A}$	10 nA	$\pm(0.3\% + 10 \text{ nA} + 200 \text{ pA} \times V_{out})$	
$\pm 1000 \text{ nA}$	1 nA	$\pm(0.5\% + 1 \text{ nA} + 20 \text{ pA} \times V_{out})$	
$\pm 100 \text{ nA}$	100 pA	$\pm(0.5\% + 100 \text{ pA} + 2 \text{ pA} \times V_{out})$	
$\pm 10 \text{ nA}$	10 pA	$\pm(1\% + 15 \text{ pA} + 200 \text{ fA} \times V_{out})$	
$\pm 1000 \text{ pA}$	1 pA**	$\pm(1\% + 6 \text{ pA} + 20 \text{ fA} \times V_{out})$	

* V_{out} is SMU output voltage in volts.

**50 fA resolution in current monitor mode.

- Accuracy specifications are given as \pm % of reading when measuring or \pm % of setting when sourcing.
- Accuracy tolerances are specified at $23^\circ\text{C} \pm 5^\circ\text{C}$, after a 40 minute warm-up time, with AUTO CAL on, and specified at the rear panel connector terminals referenced to SMU common. Tolerances are doubled for the extended temperature range of 10°C to 40°C .
- Maximum current when SMUs are sourcing voltage.
- Maximum voltage compliance when SMUs are sourcing current.

SMU Voltage/Current Compliance Limit:

Compliance voltage and current resolution are the same as listed in Table 1 and Table 2. An exception is that maximum compliance current resolution is 50 pA.

Compliance voltage accuracy is the same as listed in Table 1. Compliance current accuracy is \pm (1% of range + 10 pA).

Voltage/Current Sweep Characteristics

Each SMU source can be swept using Variable 1 (VAR 1), Variable 2 (VAR 2) or Synchronously Variable (VAR 1') mode.

Variable 1: Variable 1 can be swept linearly or logarithmically.

Linear sweep is a staircase output of voltage or current. Sweep parameters include START, STOP and STEP levels. These parameters can be varied by the user.

Log sweep is also a staircase, but at 10, 25 or 50 points per decade. The maximum number of data points is limited to 1024 for a single VAR 1 sweep or 1140 for a multiple sweep.

Time domain sweep is accessed when VAR 1 is not assigned a source function. An initial WAIT time and a time interval are specified. Wait time is specified up to 100s with resolution of 10 ms. Measurement interval is specified up to 10s with resolution of 10 ms. Maximum number of data points is 1024.

Variable 2: Variable 2 sweep is a staircase with specified number of steps. Variable 2 is incremented after completion of each VAR 1 sweep.

Synchronously Variable (VAR 1'): VAR 1' output provides a sweep synchronous with VAR 1 but at output levels proportional to a fixed ratio or offset relative to VAR 1. The ratio is defined as $\text{VAR } 1' = a \times \text{VAR } 1$, where a is a fixed ratio of ± 0.01 to ± 10 . An offset is defined as $\text{VAR } 1' = b + \text{VAR } 1$, where b is any value that will not cause VAR 1' to exceed the maximum allowable source current or voltage compliance.

Hold Time: Hold time is defined as the delay from application of initial output level to start of the first delay time. See Figure 1. Hold time can be varied from 0 to 650s \pm (0.5% + 9 ms) with 10 ms resolution.

Delay Time: Delay time is defined as the delay time from application of step output level to start of measurement. See Figure 1. Delay time can be set from 0 to 6.5s \pm (0.1% + 5 \times N* ms) with 1 ms maximum resolution.

*N: number of monitor channels.

Figure 1. Sweep Sequence

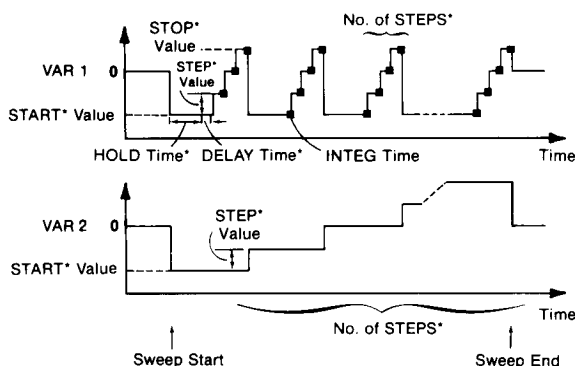

Note: *Setting Value

Voltage Sources (V_S) Characteristics

Output resistance: $\leq 0.2\Omega$

Maximum capacitive load: 1000 pF

Table 3
 V_S Voltage Output Range
Also see "Reference Data" section

Output Voltage Range	Resolution	Accuracy	Max. Output Current
$\pm 20V$	1 mV	$\pm(0.5\% \text{ of setting} + 10 \text{ mV})$	10 mA

Voltage Monitors (V_M) Characteristics

Input resistance: $1\text{ M}\Omega \pm 1\%$ paralleled by $100\text{ pF} \pm 10\%$

Table 4
 V_M Voltage Measurement Range
Also see "Reference Data" section

Measurement Voltage Range	Resolution	Accuracy
$\pm 2\text{V}$	$100\ \mu\text{V}$	$\pm (0.5\% \text{ of reading} + 10\text{ mV})$
$\pm 20\text{V}$	1 mV	$\pm (0.2\% \text{ of reading} + 10\text{ mV})$

Shared Characteristics of SMU, V_S and V_M

Maximum allowable terminal voltage: 100V peak across SMU and V_M input terminals or SMU and V_S output terminals, or between those terminals and guard; and 42V maximum from Common to Ground.

DISPLAY

CRT Size: 152.4 mm (6 inch) diagonal CRT.

CRT Visible Area: 116 mm (4.6 inches) \times 92 mm (3.6 inches).

Screen Resolution: 2048 \times 2048 points.

External CRT Analog Output: X, Y and Z outputs of 0 to 1 Vdc into $330\ \Omega$ for X and Y, and $240\ \Omega$ for Z output, are available at rear panel BNC connectors.

DATA STORAGE

Micro Flexible Disc: 630k byte, double sided, double density

Available User Records: 2432

File Sizes:

Measurement Setup:	5 records
Measurement Data plus Setup:	23 records
Auto Sequence Program:	4 records
Operating System:	254 records

ANALYSIS

Calculation

The HP 4145B does calculations with 7 digit resolution and displays 5 digits.

Constants Available on the Keyboard:

Keyboard constants are stored in memory as follows:

- q: Electron charge (1.602189×10^{-19} Coulomb)
- k: Boltzmann's Constant (1.380662×10^{-23} J/ $^\circ\text{K}$)
- e: Dielectric constant of a vacuum (8.854185×10^{-12} F/m)

The following unit symbols are also available on the keyboard. m(10⁻³), μ (10⁻⁶), n(10⁻⁹), p(10⁻¹²)

Analysis Functions:

Overlay Comparison: STORE and RECALL capabilities permit a graphical presentation of results which can be stored and later recalled and superimposed on an existing display.

While in the Schmoo Display Mode, stored data and present data are alternately displayed, with the RECALL key acting as a toggle switch. Only one set of data can be stored. Scaling information is not included.

Marker: In the Graphics Display Mode a marker may be superimposed on both the X-Y1 and X-Y2 traces. A numeric display of their coordinates is displayed.

Interpolate: In the Graphics Display Mode a linear interpolation between two adjacent measurement data points is provided. Interpolated values of X-Y1 and X-Y2 are displayed at maximum display resolution of 2048 \times 2048 points.

Cursor: In the Graphics Display Mode the coordinates of the intersection of moveable vertical and horizontal lines is displayed. A cursor is available for both X-Y1 and X-Y2 graphs. In the List and Matrix Displays, a flashing arrow indicates a selected row of data. In the Schmoo Display, the Z-axis value of the intensified symbol is displayed.

Auto Scale: In the Graphics Display Mode, X and Y scale factors are automatically adjusted to yield optimum display of measured data.

Zoom Function (← → ← → ↓ ↑): In the Graphics Display Mode, the ZOOM function expands by two or contracts to 1/2 the area surrounding the cursor.

Line: In the Graphics Display Mode, two variable slope lines can be displayed. These lines can be used as tangents to determine slope and X and Y intercepts of dc characteristics curves.

Move Window: In the Graphics Display Mode, the MOVE WINDOW centers the display around the cursor.

General Specifications

Self-Test Function: When power is turned ON, the HP 4145B automatically sequences through a self-test that verifies operational status of major functional blocks. Self-test can be actuated via HP-IB or via keyboard operation.

Operating Temperature Range: +10 $^\circ\text{C}$ to +40 $^\circ\text{C}$; $\leq 70\%$ RH at 40 $^\circ\text{C}$, permissible temperature change $\leq 1^\circ\text{C}/5\text{ min}$; maximum wet-bulb temperature 29 $^\circ\text{C}$.

Power Requirements: 100/120/220V $\pm 10\%$; 240V - 10% + 5%; 48 to 66 Hz; 270 VA max.

Dimensions: 426 mm (16.75 in)W \times 235 mm (9.06 in)H \times 612 mm (24.1 in)D

Weight: 27 kg (59 lbs) approximately for HP 4145A mainframe. 33 kg (73 lbs) includes mainframe and furnished accessories.

Reference Data

Reference data are typical values given for information purposes.

Source Monitor Unit (SMU)

Measurement Time: Measurement time = response time + ranging time + integration time.

SMU response time includes setup and settling time plus wait time. Wait time is microprocessor controlled and dependent on current range, as shown in Table 5.

Table 5
SMU Response Time

Current Range	Setup/Settling time	SMU Wait Time
100 nA to 100 mA	2.7 ms	0.2 ms
1 nA and 10 nA	2.7 ms	47.5 ms

Ranging time is dependent on number of ranges required during measurement. Lower ranges require more ranging time than the higher ranges. Ranging time can vary from 4 ms to 74 ms.

Integration time is 3.6 ms in SHORT, 16.7 ms in MED at 60 Hz line frequency (20 ms at 50 Hz); and 267 ms in LONG at 60 Hz (320 ms at 50 Hz).

Example: minimum measurement time = 2.7 ms + 0.2 ms + 3.6 ms = 6.5 ms/point

- Notes: 1. In the Graphics Display Mode, a CRT write time of 5.6 ms per point must be added to measurement time.
2. Delay time, if included in a measurement, must also be added to total measurement time.

Offset current of voltage measurement: 6 pA + 2 pA \times ($V_{\text{out}}/100$).

Offset voltage of current measurement: 10 mV + 0.4 Ω \times I_{out} .

Noise Characteristics

Voltage source noise: 0.01% of range (rms).

Current source noise: 0.03% of range + 3 pA + 0.005 pA × C_g* (rms).

Voltage monitor: 0.02% of range (peak to peak).

Current monitor: 0.3% of range + 10 pA (peak to peak).

*C_g is externally added capacitance from the guard terminal to center conductor, and expressed in pF.

Output Overshoot

Voltage source: 5 mV

Current source: ≤ 1%

Current Range Switching Transient Noise

Range increment: 0.01% of voltage range + 10 mV*.

Range decrement: 10 mV*.

Maximum internal guard to ground capacitance: 700 pF

Guard potential offset: 1 mV

Guard current induced voltage error: 100Ω × I_g where I_g is the guard current.

*When switching between 10 nA and 100 nA ranges, add 120/(3 + C_x) mV where C_x is the load capacitance in pF.

Voltage Source (V_s)

Output noise: 6 mV rms

Voltage Monitor (V_M)

Noise level at input: 0.3 mV p-p on 2 V range*

3 mV p-p on 20 V range

*With integration time set to MED or LONG

Source Monitor Unit (SMU) and Voltage Monitor (V_M)

Noise rejection guidelines are valid when line frequency is either 50 Hz or 60 Hz.

Normal mode noise rejection: ≥ 60 dB

Common mode noise rejection:

Current monitor: ≤ 2 pA/V*

*With integration time set to MED or LONG

Ordering Information

STANDARD CONFIGURATION

HP 4145B Semiconductor Parameter Analyzer

ACCESSORIES FURNISHED

HP 16058A Test Fixture

04145-60001 Connector Plate

04145-61622 Triaxial Cable (3m), 4 ea.

04145-61630 BNC Cable (3m), 4 ea.

04145-61623 Shorting Connector

04145-61501 System Disc

OPTIONS

Option 907: Front Handle Kit
(HP P/N 5061-0091)

Option 908: Rack Flange Kit
(HP P/N 5061-0079)

Option 909: Rack and Handle Kit
(HP P/N 5061-0085)

Option 910: Extra Manual
(HP P/N 04145-90000)

AVAILABLE ACCESSORIES

16267A File Transfer Software

HP 4145A Software (Special HP 4145A Operating System) transfers files from the HP 4145A to the HP 4145B.

16268A BS&DM* File Creation Software

Operates on the HP 9000 Series 200/300 Computers. Reads data from the HP 4145B disc and converts the data from HP 4145B format to the BS&DM* format. (3.5 inch flexible disc.)

*BS&DM is the Basic Statistics and Data Manipulation format used in the HP 98820A/B/C Statistical Library.

92192A 3-1/2" Double-sided Microfloppy (Box of 10)

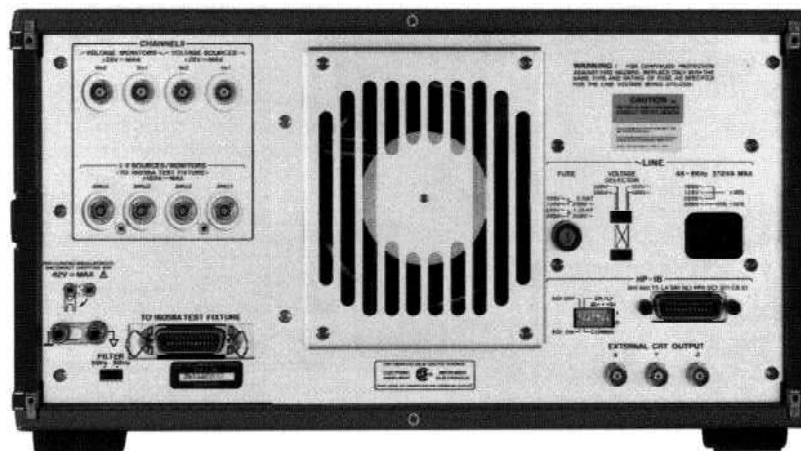

HP 4145B Rear Panel includes 4 triax connectors for SMUs, 2 each BNCs for V_s and V_M, HP 16058A test fixture connector and HP-IB connector.

For more information, call your local HP sales office listed in the telephone directory white pages. Ask for the Electronic Instrument Department, or write to Hewlett-Packard: **U.S.A.** - P.O. Box 10301, Palo Alto, CA 94303-0890. **Europe** - P.O. Box 999, 1180 AZ Amstelveen, The Netherlands. **Canada** - 6877 Goreway Drive, Mississauga, L4V 1M8, Ontario. **Japan** - Yokogawa-Hewlett-Packard Ltd., 3-29-21, Takaido-Higashi, Suginami-ku, Tokyo 168. **Far East** - Hewlett-Packard Asia Headquarters, 47/F China Resources Building, 26 Harbour Road, Wanchai Hong Kong. **Australasia** - Hewlett-Packard Australia Ltd., 31-41 Joseph Street, Blackburn, Victoria 3130 Australia. **Latin America** - Hewlett-Packard Latin America Headquarters, 3495 Deer Creek Rd., Palo Alto, CA 94304. For all other areas, please write to: Hewlett-Packard Intercontinental Headquarters, 3495 Deer Creek Rd., Palo Alto, CA 94304.