

Discontinued Product—Support Information Only

This literature was published years prior to the establishment of Agilent Technologies as a company independent from Hewlett-Packard and describes products or services now available through Agilent. It may also refer to products/services no longer supported by Agilent. We regret any inconvenience caused by obsolete information. For the latest information on Agilent's test and measurement products go to:

www.agilent.com/find/products

Or in the US, call Agilent Technologies at 1-800-452-4844 (8am–8pm EST)



Agilent Technologies

HP 64147A Emulator for Mitsubishi MELPS 7700 and 7750/51 Series Microprocessors

Product Overview

Design, debug and
integrate real-time
embedded systems

The HP 64147A emulator supports Mitsubishi MELPS 7700 and 7750/51 Series up to 25 MHz. This emulator supports various versions of MELPS 7700 and 7750/51 Series microprocessors by replacing the emulation pod or emulation processor in both 3V and 5V versions. These emulation systems offer the real-time measurements you need to develop MELPS 7700 and 7750/51 embedded systems. Measurement capabilities include interpreted displays of on-chip registers, non-intrusive display of emulation memory, deep trace analysis and hardware breakpoints.

HP's host-independent emulation and analysis systems can be controlled from a simple terminal, HP 9000 workstation, Sun SPARCstations, and IBM PC compatibles. You can access these systems through a selection of user interfaces, including an X/motif-based interface for HP workstations and Sun SPARCstations, and a MS Windows-based interface for IBM PC compatibles. This allows you to open several emulation and analysis windows for simultaneous display during a session, providing visibility on several parameters at once.

Features

- 3V and 5V versions of MELPS 7700 and 7750/51 Series microprocessors
- No-wait state operation up to 25 MHz at 5V and 12 MHz at 3V
- Eight real-time hardware breakpoints
- Unlimited software execution breakpoints
- Disassembly of MELPS 7700 and 7750/51 Series instruction set
- Display and modify functions for all registers (including SFR), memory, and I/O ports
- Background and foreground monitors
- No mis-trigger of trace analysis by the real-time instruction dequeuing
- Real-time code coverage analysis
- Simulated I/O (on workstation)
- Cross-triggering between another emulator, logic analyzer, or oscilloscope
- Support for Mitsubishi assembler and compiler with HP real-time C debugger on IBM PC compatibles, and HP graphical user interface on HP 9000 Series 300/400/700 and Sun SPARCstations
- Support for IAR SYSTEMS assembler and compiler with HP real-time C debugger on IBM PC compatibles
- Support for Microtec Research, Inc. assembler and compiler with HP real-time C debugger on IBM PC compatibles
- Compatible with IAR SYSTEMS C-SPY debugger on IBM PC compatibles
- Compatible with MRI XRAY debugger on HP 9000 Series 300/400, Sun SPARCstations, and IBM PC compatibles

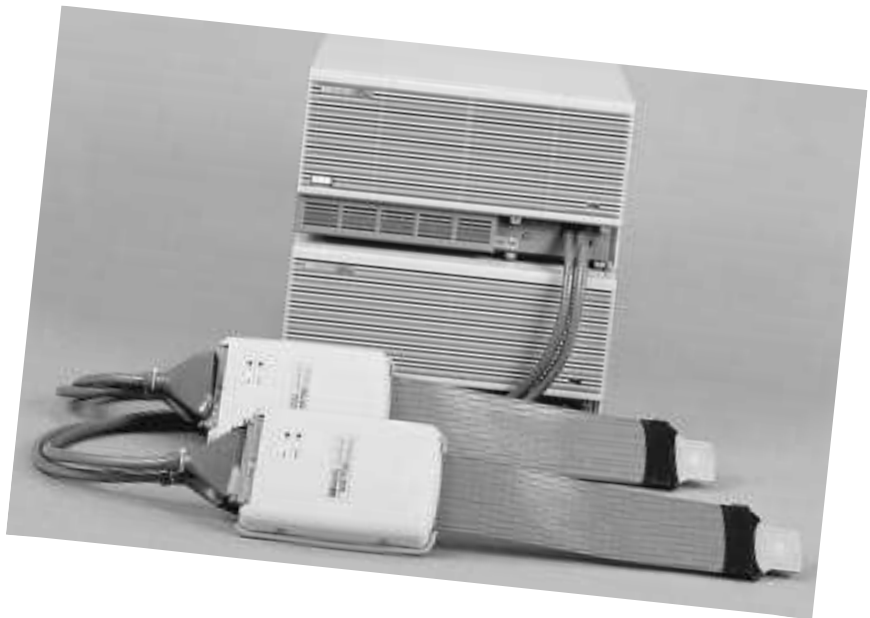

Modular HP 64700 Series system

Emulation Bus Analyzer

- Support for 48 channels emulation bus analyzer
- Support for 64 channels emulation bus analyzer with 16 channels of external state/timing
- Support for 80 channels with trace buffer depths of 1K, 8K, 64K, or 256K
- Real-time instruction dequeuing
- Eight events, each consisting of address, status and data comparators
- Eight-level event sequencing
- Time tag with 20-nsec resolution (64794x) and state counts
- Prestore

Emulation Memory

- Dual ports for modification and display of emulation memory without processor interruption
- 512-KB and 2-MB memory configurations
- Mapping in 256-byte block

Software Support

- Real-time operating system measurement tools
- Support for real-time, software performance analyzer with MRI language on workstation.

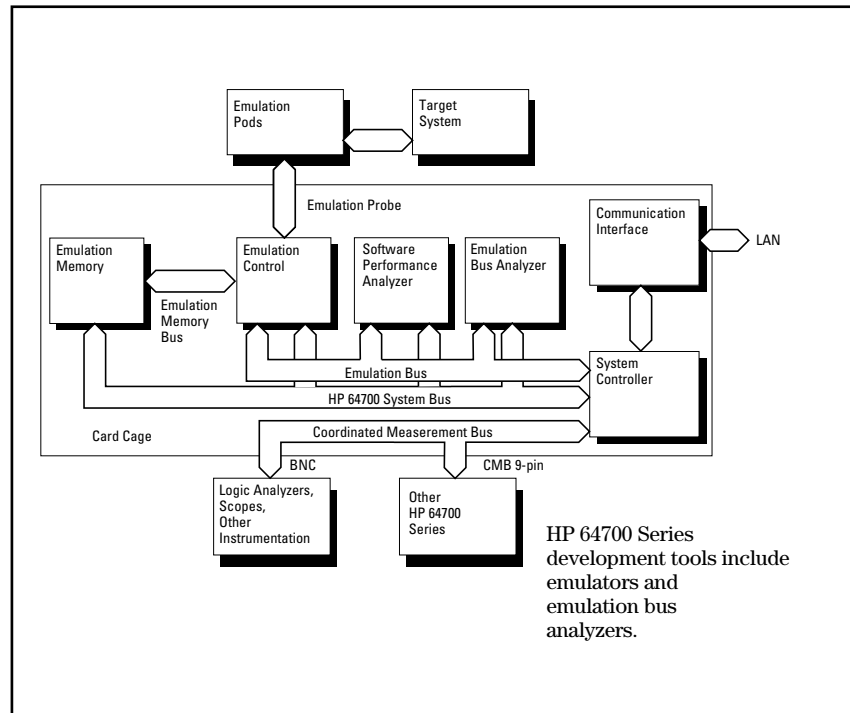

Card Cage

The card cage is the basis for modular emulators and analyzers. It is easily disassembled for cost-saving reconfiguration to support 8-, 16-, and 32-bit processors.

The card cage host control card contains LAN capability, along with RS-232-C/RS-422 serial port and system configuration firmware. System, emulation, and analysis firmware are always resident and may be updated at anytime.

Networking

In many embedded design environments, it is not possible for each member of a design team to have a target system and an emulator, making remote access from a networked host essential. The HP 64700 series emulators offer a LAN connection that enables you to share a central emulator and target from either a PC or workstation.

In addition, the rapid file transfers—rates of up to 6 MB per minute—increase your productivity. The card cage connects to all popular Ethernet/803.2 networks through a 10Base2 ThinLAN BNC connector or a 15-pin AUI attachment unit interface. The system supports TCP/IP protocols, LAN gateways, and ARPA/Berkeley standards.

Emulation Bus Analysis

Emulation bus analysis provides real-time, nonintrusive operation along with extensive triggering, tracing and qualification features. Analysis features offer selective tracing, time-tagging, prestore, and a selection of trace depths: 1K, 8K, 64K, or 256K. These comprehensive resources combine to solve both simple and complex problems. Real-time, nonintrusive analysis is achieved through a dual-bus architecture. This allows traces to be set up and reviewed without breaking processor execution.

Up to eight hardware breakpoint resources, each consisting of address, data, and status event comparators, can be combined in sequential trace specifications, using “find A, followed by B...” constructs up to eight levels deep. You can apply a range comparator to address or data events at any one of these levels. The analyzer will trigger on and store all subsequent executions, or store only specified execution information. Precise-time tagging of events helps you identify discrepancies in code execution, so the analyzer logs the execution time with each event. Bus cycle, instruction, and module duration can be measured at full processor speeds.

Prestore helps you pinpoint possible problem areas in your code. Prestore can determine which of several different functions is accessing a variable and is responsible for corrupting it.

Real-Time Emulation

The HP 64147A contains the emulation pod with the microprocessor, emulation monitor, run-control circuits, and up to 2 MB of dual-port emulation memory. The emulator for MELPS 7700 and 7750/51 Series microprocessors includes background and foreground monitors. The background monitor uses no target address space; the foreground monitor is used for interrupt-sensitive systems or for customizing the monitor to the target system. For example, a foreground monitor can respond to target system interrupts while in an idle loop.

Extensive breakpoint capabilities allow you to define where to stop code execution. Software breakpoints can be set up in the emulator, allowing execution to be halted at an instruction point.

Real-time hardware break events increase the flexibility and power of this feature, extending functionality to include stopping at processor address, data, status points, or a combination of all three.

Flexible Memory Configuration

Emulation memory is available as replacement memory in your embedded design, available in 512-KB or 2-MB sizes mappable in 256-byte blocks. Dual-port emulation memory lets you display and modify emulation memory locations without interrupting target processor execution. All of these features give you considerable flexibility in a nonintrusive development environment.

Symbolic Support

Symbolic debugging is available when using the PC-hosted, real-time C debugger, and workstation-hosted software tools. Symbolic debugging clarifies interpretation by allowing you to see program symbols in the trace list. This process lets you quickly identify problems involving the interaction of software and hardware. You also can use symbols in emulation commands and expressions to simplify command entries and user interaction.

Workstation-Hosted Environment

The HP embedded debug environment provides useful tools for software development, including an emulator/analyzer interface and a real-time software performance analyzer.

The emulator/analyzer tool lets you perform trace analysis, set breakpoints, and establish emulator configuration parameters. In addition, the graphical interface tool is integrated with the embedded debug environment, which coordinates high-level software debugging with low-level microprocessor run control.

Optional software performance analysis enables you to tune and verify the time-critical aspects of your design with MRI language, at both the C source and assembly language levels. Through automated one-key setup, this system quickly identifies code bottlenecks and gathers statistics and timing information that aid in solving time-critical problems. The software performance analyzer operates with HP 9000 Series 300/400/700 workstations and Sun SPARCstations.

HP debug environment supports language tools from Microtec Research, Inc. MRI provides software tools that are compatible with the HP 64147A emulator. This toolset includes the MCCM77 C cross compiler and the ASMM77 assembler, and the XRAYM77 debugger. The XRAYM77 executes source or assembly language programs and lets you control the flow of program execution. The debugger's window-oriented interface simultaneously displays all program information.

It also lets you display and modify the value of any C or assembly language variables in its declared format. This toolset is available on the HP 9000 Series 300/400 workstations, and Sun SPARCstations.

PC-Hosted Environment

The real-time C debugger is a mouse driven, MS Windows based graphical user interface for HP 64700 emulators. The debugger takes full advantage of the emulator's dual-bus architecture and dual-ported memory to perform many C and assembly debug functions while the target runs at full speed. This means that you can perform C debugger functions such as setup of breakpoints, display and edit of C variables, and measurement of C program behavior without interrupting program execution. Traditionally you could only run these functions when the user program was stopped. The real-time C debugger supports IAR SYSTEMS, MRI, and Mitsubishi language tools.

A PC-based development environment is a solution tailored to the microprocessor software development and analysis needs of individual engineers and small design teams. High-performance tools at entry-level costs include an IBM PC compatible, HP 64700 Series emulators, a windowed user interface, and software development tools.

The IAR SYSTEMS toolset and MRI toolset for MELPS 7700 are compatible with the HP 64147A emulator hosted on IBM PC compatibles. Contact a field representative of IAR SYSTEMS and MRI for detailed information.

Terminal mode operation

A firmware-resident ASCII terminal interface is embedded in the emulator, supplying commands for all emulation and analysis features. Commands are ASCII strings; file transfers using industry-standard formats are accepted. Since a terminal can access these commands, host independence is realized.

HP 64147A Emulator Specifications

Supported Mitsubishi Processors

The HP 64147A emulator supports most of Mitsubishi 7700 and 7750/51 Series processors by changing the emulation pod or the emulation processor. HP will continue to add supported processors, so the processor support list is growing. Contact an HP sales representative for the latest update and detailed information on supported processors.

Pods and emulation processors other than the standard pod and emulation processors are supplied from Mitsubishi dealers. Please refer to the Mitsubishi catalog for the location of local sales and support offices to order different emulation pods.

Specifications

Processor Compatibility Model 64147A	Mitsubishi microprocessors MELPS 7700 and 7750/51 Series operating at TTL levels (3V or 5V).
Note: Two emulation processors are supplied with the HP standard emulation pod. The M37702S1BFP processor is shipped in the pod. The M37702S4BFP shipped with the emulation pod may be installed in the pod to emulate S4BFP/SP-based systems.	
Electrical	
Maximum Clock Speed	25MHz with no wait states at 5V 12MHz with no wait states at 3V Required for emulation or target memory
Minimum Clock Speed	1MHz
Power	Primary power supplied by card cage
Environmental	
Temperature	Operating, 0 to +40 °C (+32 to +104F) Nonoperating, -40 to +70°C (-40 to +158F)
Altitude	Operating, 4600m (15,000 ft); Nonoperating, 15300m (50,000 ft)
Regulatory Compliance	When installed in HP 64700 card cage
Electromagnetic Interference	EN55011 Group1 Class A
Safety	Self-certified to UL 1244, IEC 348, CSA-556B
Cable Length	Emulator to emulation pod: approximately 1000mm (40") Pod to target system: approximately 260 mm (10")
Probe Dimensions	See drawing below

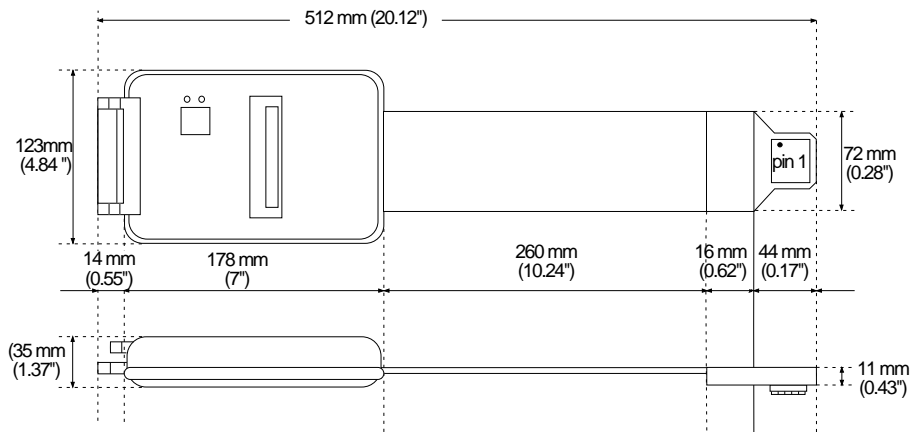

HP 64147A AC Timing Specifications

E and Ø timings

Characteristic	Symbol	Standard value			
		Vcc=5V		Vcc=3V	
		Min.	Max.	Min.	Max.
/E propagation delay time (rising edge)	tr(E)	9.0ns	13.0ns	9.0ns	18.0ns
/E propagation delay time (falling edge)	tf(E)	9.0ns	13.0ns	9.0ns	18.0ns
Propagation delay time (rising edge)	tr(Ø1)	11.0ns	15.0ns	11.0ns	21.0ns
Propagation delay time (falling edge)	tf(Ø1)	9.5ns	13.5ns	9.5ns	18.5ns

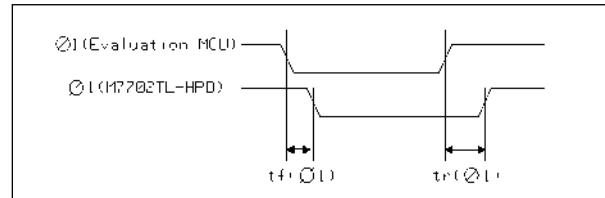
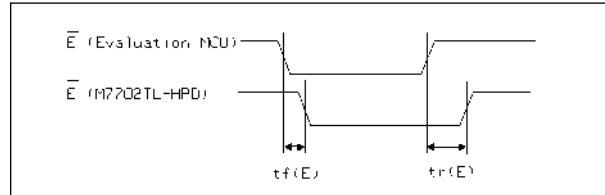

Vcc=5V, f(Xin)=25MHz

Characteristic	Symbol	Standard value			
		M37702S1BFP		HP Standard POD	
		Min.	Max.	Min.	Max.
Port input setup time (I/O port)	tsu(PnD-E)	60ns		56.0ns	
Port input hold time (I/O port)	th(E-PnD)	0ns		-22.0ns	
Port data output delay time (I/O port)	td(E-PnQ)		80ns		14.5ns
/HOLD input setup time	tsu(HOLD-E1)	55ns		54.0ns	
/HOLD input hold time	th(Ø1-HOLD)	0ns		-19.5ns	
/RDY input setup time	tsu(RDY-Ø1)	55ns		55.5ns	
/RDY input hold time	th(Ø1-RDY)	0ns		-20.0ns	
/HLDA output delay time	td(Ø1-HLDA)		50ns		53.5ns
Port P1 input setup time	tsu(P1D-E)	30ns		52.0ns	
Port P2 input setup time	tsu(P2D-E)	30ns		52.0ns	
Port P1 input hold time	th(E-P1D)	0ns		-20.0ns	
Port P2 input hold time	th(E-P2D)	0ns		-20.0ns	

Vcc=5V, f(Xin)=16MHz

Characteristic	Symbol	Standard value			
		M37702S1BFP		HP Standard POD	
		Min.	Max.	Min.	Max.
Port input setup time (I/O port)	tsu(PnD-E)	100ns		56.0ns	
Port input hold time (I/O port)	th(E-PnD)	0ns		-22.0ns	
Port data output delay time (I/O port)	td(E-PnQ)		100ns		14.5ns
/HOLD input setup time	tsu(HOLD-E1)	60ns		54.0ns	
/HOLD input hold time	th(Ø1-HOLD)	0ns		-19.5ns	
/RDY input setup time	tsu(RDY-Ø1)	60ns		55.5ns	
/RDY input hold time	th(Ø1-RDY)	0ns		-20.0ns	
/HLDA output delay time	td(Ø1-HLDA)		50ns		53.5ns
Port P1 input setup time	tsu(P1D-E)	45ns		52.0ns	
Port P2 input setup time	tsu(P2D-E)	45ns		52.0ns	
Port P1 input hold time	th(E-P1D)	0ns		-20.0ns	
Port P2 input hold time	th(E-P2D)	0ns		-20.0ns	

Vcc=5V, f(Xin)=8MHz

Characteristic	Symbol	Standard value			
		M37702S1BFP		HP Standard POD	
		Min.	Max.	Min.	Max.
Port input setup time (I/O port)	tsu(PnD-E)	200ns		56.0ns	
Port input hold time (I/O port)	th(E-PnD)	0ns		-22.0ns	
Port data output delay time (I/O port)	td(E-PnQ)		200ns		14.5ns
/HOLD input setup time	tsu(HOLD-E1)	70ns		54.0ns	
/HOLD input hold time	th(Ø1-HOLD)	0ns		-19.5ns	
/RDY input setup time	tsu(RDY-Ø1)	70ns		55.5ns	
/RDY input hold time	th(Ø1-RDY)	0ns		-20.0ns	
/HLDA output delay time	td(Ø1-HLDA)		100ns		53.5ns
Port P1 input setup time	tsu(P1D-E)	60ns		52.0ns	
Port P2 input setup time	tsu(P2D-E)	60ns		52.0ns	
Port P1 input hold time	th(E-P1D)	0ns		-20.0ns	
Port P2 input hold time	th(E-P2D)	0ns		-20.0ns	

Vcc=3V, f(Xin)=8MHz

Characteristic	Symbol	Standard value			
		M37702S1BFP		HP Standard POD	
		Min.	Max.	Min.	Max.
Port input setup time (I/O port)	tsu(PnD-E)	300ns		93.0ns	
Port input hold time (I/O port)	th(E-PnD)	0ns		-22.0ns	
Port data output delay time (I/O port)	td(E-PnQ)		300ns		25.0ns
/HOLD input setup time	tsu(HOLD-E1)	90ns		96.0ns	
/HOLD input hold time	th(Ø1-HOLD)	0ns		-19.5ns	
/RDY input setup time	tsu(RDY-Ø1)	90ns		97.5ns	
/RDY input hold time	th(Ø1-RDY)	0ns		-20.0ns	
/HLDA output delay time	td(Ø1-HLDA)		120ns		59.0ns
Port P1 input setup time	tsu(P1D-E)	80ns		87.5ns	
Port P2 input setup time	tsu(P2D-E)	80ns		87.5ns	
Port P1 input hold time	th(E-P1D)	0ns		-20.0ns	
Port P2 input hold time	th(E-P2D)	0ns		-20.0ns	

Ordering Information

Terminal-Based Emulation System for MELPS 7700 and 7750/51 Series Processor

Model	Description
64147A	Emulator card with emulation pod for Mitsubishi MELPS 7700 and 7750/51 Series processors. Terminating in an 80-pin LCC probe. An 80-pin LCC to 64-pin DIP adapter is included.
opt 001	Delete the standard pod which is required for the performance verification test of the emulator. A user must have one standard pod at least at one site. The other emulation pods must be purchased from Mitsubishi dealers.
64727A	512-KB emulation memory board for 16-bit emulators
64706A	1K deep 48-channel emulation bus analyzer card
64700B	Card cage

Emulation System Options

Model	Description
64729A	2-MB emulation memory card for 16-bit emulators
64703A	64-channel emulation bus analyzer card with 16 bits of external state/timing analysis
64704A	1K-deep emulation bus analyzer card, 80-channel
64794A	8K-deep emulation bus analyzer card, 80-channel
64794C	64K-deep emulation bus analyzer card, 80-channel
64794D	256K-deep emulation bus analyzer card, 80-channel
64708A	Software performance analyzer card (supported on HP 9000 Series workstations and Sun SPARCstations, HP B1487A software required)
64023A	CMB cable (4m long; includes three 9-pin connectors)

Software Options

For each software model number ordered, purchase one media option and at least one license option for each concurrent user.

Model	Description
B3078B	Graphical user interface for workstation
B1487A	Software performance analyzer (required HP 64708A analyzer card)

Media/License Options

opt AAH	HP9000 Series 300/400 manuals/media (DDS DAT tape)
opt UBX	HP9000 Series 300/400 single-user license
opt AAY	HP9000 Series 700 manuals/media (DDS DAT tape)
opt UBY	HP9000 Series 700 single-user license
opt AAV	Sun SPARCstations manuals/media (1/4inch cartridge tape)
opt UBK	Sun SPARCstations single-user license

Model	Description
B3630A	Real-time C debugger interface for IBM PC compatibles

Media/License Options

opt AJ4	IBM 3 1/2" manuals/media
opt UDY	IBM single-user license

Software Support

HP provides software upgrades through the purchase of the software materials subscription (SMS) service. Contact your HP field engineer for more information.

HP Sales Support Offices

United States

Microprocessor Development Hotline
tel: (800) 447 3282
fax: (719) 590 5054

Canada:

Hewlett-Packard Ltd.
6877 Goreway Drive
Mississauga, Ontario
L4V 1M8
(416) 678 9430

Europe:

Hewlett-Packard S.A.
European Marketing Center
P.O. Box 999
1180 AZ Amstelveen
The Netherlands

Japan:

Hewlett-Packard Japan, Ltd.
9-1, Takakura-cho, Hachioji-shi
Tokyo, 192 Japan
0120-421-345

Latin America:

Latin American Region
Headquarters
Monte Pelvoux No. 111
Lomas de Chapultepec
11000 Mexico, D.F. Mexico
(525) 202 0155

Australia/New Zealand:

Hewlett-Packard Australia Ltd.
31-41 Jeseoph Street
Blackburn, Victoria 3130
Melbourne, Australia
(03) 895 2895

Far East:

Hewlett-Packard Asia Ltd.
22/F Bond Centre, West Tower
89 Queensway, Central, Hong Kong
8487777

* MELPS is a registered trademark of Mitsubishi Electric Corporation.

* C-SPY Debugger is a trademark of IAR SYSTEMS AB.

* XRAY Debugger is a trademark of Microtec Research, Inc.

* SPARCstations is a trademark of Sun Microsystems, Inc.

**Data subject to change
Printed in the U.S.A. 11/95
5963-9987E**