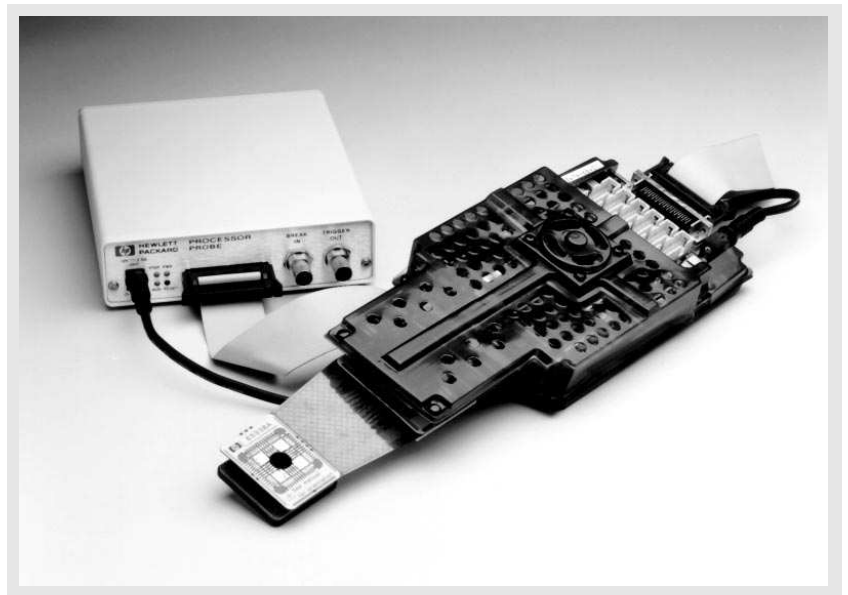

HP E3474A Distributed Emulation for Siemens C167 Series Microcontrollers

Product Overview

Design, Debug,
and Integrate real-time
embedded system

Distributed Emulation Advantages and Features

- Real-time zero wait state emulation
- Emulation at full speed of microcontroller (25 MHz)
- 128 K IROM substitution memory, accessible without processor interruption
- Read and write messages to XBUS CAN module
- Unlimited software breakpoints for all RAM and for IROM
- Hardware breakpoints provided by logic analyzer
- Siemens C166 family support for: C167CR-LM, C167CR-16FM, C167CR-16RM, C167CR-4RM, C167SR-LM, C167S-4RM, and C167-LM
- Direct connection to 144 pin .65mm MQFP using HP's patented elastomeric probing technology
- 100 MHz real-time trace with 2 M acquisition depth using HP logic analyzers



HP has developed a new methodology called "Distributed Emulation" that leaps over the barriers imposed on traditional emulators by today's complex processors.

The HP E3474A distributed emulation solution for the Siemens C167 series of microcontrollers, divides the traditional processor into four parts: the processor probe, active preprocessor, surface mount probing solution, and real-time trace acquisition.

Real-time trace acquisition is provided by an HP logic analyzer, which is purchased separately. This approach provides a solution for high speed bus analysis, up to 100 MHz, using the state analysis capability of the logic analyzer. The logic analyzer also provides time-correlated analysis of other signals and buses on the target system.

Now you can purchase just the tools you need to solve your particular measurement problems.

Distributed Emulation

Processor Probe:
Controls the target system by executing run control, setting breakpoints, displaying memory contents and accessing register values. Using LAN, it handles communication with debugger software on your host computer.

Active Preprocessor :
Uses C167E bondout chip to provide complete access to all internal registers. XBUS, IRAM and IROM.

Logic Analyzer:
Execute real-time trace by capturing data to/from the processor on the emulation probe.

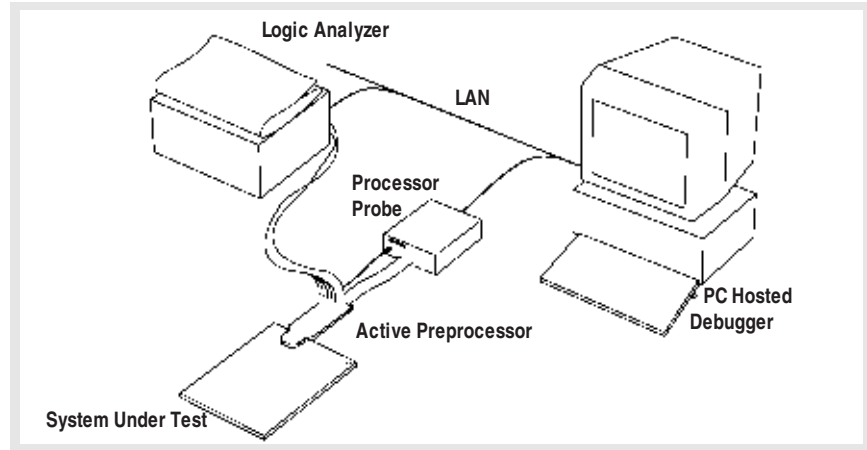

Figure 1: Concept of Distributed Emulation

IRAM and user memory read and write access with minimum processor interruption

Up to 500 MHz timing analysis when using HP logic analyzer

The use of LAN for easy sharing of data and tools across the entire design team

Active XBUS and X PER signals in background monitor mode

Change PLL clock speed from processor configuration

Time-correlation between high level source code and real-time trace with HP B3740A software analysis tool

Time-correlation between high level source code and real-time trace with HP B3740A software analysis tool

Team Synergy

Distributed emulation allows team members to work concurrently on a single solution. The system optimizes each function and each component for a critical portion of the design task. This means team members use the optimum equipment, and work with common platforms and configurations. Connection on the LAN makes for easy sharing of tools and data. This team synergy increases the cost-effectiveness and flexibility of the entire project.

Cost Reduction

Distributed emulation offers a scaleable modular family of tools that lets users tailor the capabilities they need to their budget. Users can select the most suitable or cost-effective one from HP's wide selection of logic analyzers. Distributed emulation is especially effective in a large scale embedded project where it is impractical to purchase a conventional processor for everyone. A logic analyzer is not specific to one processor, so it is reusable for future processors.

Cross-Domain Correlation and High-Speed State/Timing

During system integration, subtle problems elude your team for days, or even weeks. Often these problems can result from a hardware timing issue that causes erratic behavior in the software. Because logic analyzers have 100 MHz state/500 MHz timing features, 2 M deep acquisition memory, software performance, and oscilloscope capabilities, you can apply their power to correlate glitches, timing margins, and source code execution. Now you can quickly and accurately determine the root cause of your most difficult hardware, software, and system integration problems with minimum effect on code execution.

Figure 2.

Development Environment for Application Engineer:

- Program run and stop
- Break point setting
- Display and modify memory and registers

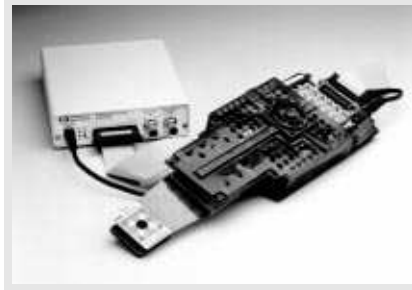

Figure 3.

Development Environment for Firmware Engineer:

- Real-time trace
- Display and modify memory and registers
- Measure real execution time
- Break on memory read or write



Figure 4.

Development Environment for System Integrator:

- synchronize timing with/analog measurement with real-time program flow trace using a cross trigger function
- Display and modify memory and registers
- Measure real execution time

**Individually Tailored Functionality**

Today's complex designs require that different team members perform different tasks. For instance, application engineers spend most of their time on pure software development and use run control and a C debugger. In this case, they do not need a logic analyzer for real-time trace analysis. By purchasing just the HP E3474A they can decrease the cost of their development tools. (Figure 2)

However, firmware engineers often use real-time trace analysis and sometimes need very deep trace history. To satisfy their requirements at low cost, they could choose the HP 1671D portable logic analyzer, for example, which supports up to a 100 MHz state and 1 M trace depth. (Figure 3)

A system integrator, who is responsible for complicated problems of hardware and software, requires timing measurement and/or analog measurement synchronized with real-time program flow trace using a cross trigger function. In this case, a user can choose, for example, the HP 16555D analyzer board (500 MHz timing and 100 MHz state and 2 M state depth) and HP 16534A digitizing oscilloscope board (2 GSa/s, 500 MHz BW and 2 channels) into an HP 16500C logic analyzer system main frame. This combination is a powerful debug environment for the system integrator. (Figure 4)

Support for Siemens SAB 80C166 family of microcontroller

- E3474A supports Siemens C167CR-LM, C167-LM, C167CR-16FM, C167CR-16RM, C167CR-4RM, C167SR-LM, C167S-4RM

The HP E3474A Contains

- Processor probe, active pre-processor, 144 pin MQFP probing solution, six termination adapters (required to connect HP logic analyzer to E3474A), cables, manuals, and software
- Processor Control Tool Set, provided with the HP 16505A Prototype Analyzer¹
- Configuration and disassembly software for the HP logic analyzers
- logic analyzer must be ordered separately

Probing Support

- Direct connection to 144 pin MQFP package using HP's patented elastomeric probing solution.
- Highly reliable mechanical and electrical connection to the surface mount device.
- This probing solution eliminates the need for a socketed development target system.
- 144 pin MQFP probing solution is supplied as a standard part of the HP E3474A and does not need to be ordered separately.
- If additional probes are required order HP E5361A.

Emulation Features

- Emulation at 25 MHz (current maximum speed of microcontroller) and 5 volts
- Minimum Clock Speed 4MHz
- Real-time no wait state execution at full speed
- 128K IROM substitution memory is accessible without processor interruption
- Unlimited number of software breakpoints
- Read and write access to the Xbus CAN module
- Display and modify IRAM with minimum processor interruption by using quick break
- Supports power-on-reset
- Display, configure, and modify on-chip peripherals through internal I/O registers
- Hardware protection for processor if improper power down sequence occurs.
- Change PLL clock speeds from processor controls
- Enable or disable serial channel 0, serial channel 1, general purpose timers, CAP-COM and A/Ds during background monitor mode
- If a debugger is not available, or desired, the E3474A can be controlled using the Processor Control Tool Set (PCT). The PCT is provided with the HP 16505A Prototype Analyzer¹.
- Emulation configuration and control can also be provided using the serial interface from any PC or workstation.

- Six termination adapters (01650-63203) are provided with the E3474A. Termination adapters provide connection from the HP logic analyzer to E3474A emulation probe.

Real-Time Trace

- Real-time, non-intrusive analysis is provided by a variety of HP logic analyzers.
 - Break software execution based on real-time trace results
 - 100 MHz maximum trace acquisition rate (state speed)
 - 500 MHz maximum timing speed (250 MHz on 1670/1D models) on channels not used by the E3474A
 - The HP E3474A requires 96 channels of logic analysis to access all of the C167 microcontroller's internal and external data bus, address bus, and status bus information
 - The HP logic analyzers have access to the following information: Instruction Pointer address of executed instructions, data source operand address at operand state, data/destination operand, address at operand state, opcode data at opcode state, ALU data at operand state
 - HP logic analyzers, when used with the E3474A provide full disassembly of the data bus information. The disassembler also can filter (suppress) unexecuted instructions, injected instructions, no data operand states, all operand states, branches, and calls/returns
- ¹The HP 16505A must be used with an HP 16500B/C logic analysis system

- Symbolic address references from the source code can be downloaded into the logic analyzer. Object module format must be IEEE695
- Acquisition memory depth:
 - 2 each 16556D² 2 M
 - 2 each 16555D² 2 M
 - 2 each 16555A² 1 M
 - 2 each 16556A² 1 M
 - 2 each 16554A² 500 K
 - 1670D 64 K (1 M w/opt. 030)
 - 1671D 64 K (1 M w.opt. 030)
 - 1660C/CS 4 K
 - 1661C/CS 4 K

²The HP 16505A Prototype Analyzer works with these analyzer cards and a 16500B or 16500C logic analysis system.⁷

Software Analyzer

HP's B3740A Software Analysis package simultaneously shows source code and real-time assembly level trace information on the PC or workstation. The source code and real-time trace information is time correlated. The B3740A works with Tasking IEEE695 format.

Debugger Support

Programmierbare Logik & Systeme GmbH (PLS) provides a full-featured debugger, **fast-view66/winHP**. This is an integrated development environment for Siemens SAB C16x microcontrollers with extensions to support the HP E3474A. It consists of fast-view66/winHP HLL Full-Screen Debugger, Professional Programmers Editor Codewright WinMAKE, and English manuals.

Fast-view66/winHP works on any PC with Windows 3.1, Win95, or NT, and is compatible with the following C166 C- compilers,

Tasking	
BSO-C166 V 5.0	
KEIL ELKETRONIK	SDK-C166 V 3.0
HighTec	GNU-C/C++

The warranty for PLS products is 1 year. Product support and updates are included, without charge, as part of the warranty.³ After one year it is possible to extend the support for 20% of the list price of fv66/HP.

PLS can be contacted by telephone: +49 (3571)4838 -0
 fax: +49 (3571) 4838 - 31
 email: Support@pls-mc.com
 address:
 PLS GmbH
 P.O.Box 1206
 D-02962 Hoyerswerda Germany

³product updates are limited to two within the one year warranty period.

Target Requirements

- Operating voltage range of the C167 processor is 4.75 - 5.25 volts
- Power to E3474A 100 volts to 240 volts at 50/60 Hz
- Reset input signal line (rstin) should be free of excessive noise and ringing
- Current limitations on Port 0 pin 1 require that the target must be able to source 1.1 mA minimum and 1.4 mA maximum
- No byte access in internal ROM
- In multiprocessor systems, care must be taken so that only the processor being emulated will be tri-stated from reset; ie. master and slave processors shouldn't share the data bus and RSTIN lines.
- All external watchdog timers must be disabled.
- To use the HP elastomeric probing for a 144 pin MQFP package, a keepout area is required. The keepout area should be 1.58" (40.2mm) X 1.58" (40.21mm) square, centered over the C167 microcontroller.
- Maximum height of components in the keepout area is 0.8mm.
- Refer to figure 6 for additional details.
- 17pfd to gnd signal loading on target
- 25 MHz maximum operating frequency

Environmental Characteristics and Specifications

Environmental Temperature

- Operating:
0 to +40 °C (+32 to +104 F)
- Non-operating:
- 40 to +70 °C
(-40 to 140 F)

Altitude

- Operating:
3100 m (10,000 ft)
- Non-operating:
4600 m (15,000 ft)

Regulatory Compliance

- Electromagnetic Interference: EN55011 (CISPR Group1 Class A)
- Safety
Self-certified to IEC 1010-1 and CSA-1010

Product Regulations

Safety

IEC 1010-1: 1990+A I / EN 61010-1: 1993
UL 31 11
CSA-C22.2 No. 10 IO. 1: 1993

EMC

This Product meets the requirements of the European Communities (EC) EMC Directive 89/336/EEC.

Emissions

EN5501 I/CISPR II I
(ISM, Group 1, Class A equipment)

Immunity

EN50082-1	Performance	
	Code	Notes
IEC 555-2	1	
IEC 555-3	1	
IEC 801-2 (ESD) 8kV AD	3	1,2
IEC 801-3 (Rad.) 3V/m	1	2
IEC 801-4 (EFT) 1 kV	1	
IEC 801-6 (Conducted)	3	2

Notes:

- 1 The target cable assembly is sensitive to ESD events. Use standard ESD preventative practices to avoid component damage.
- 2 10Base-T and 10Base-2, cables were disconnected.

Sound Pressure Level

N/A

Figure 5:

- HP 144 pin MQFP Elastomeric Probing (E5361A)
Dimension and Clearance Requirements

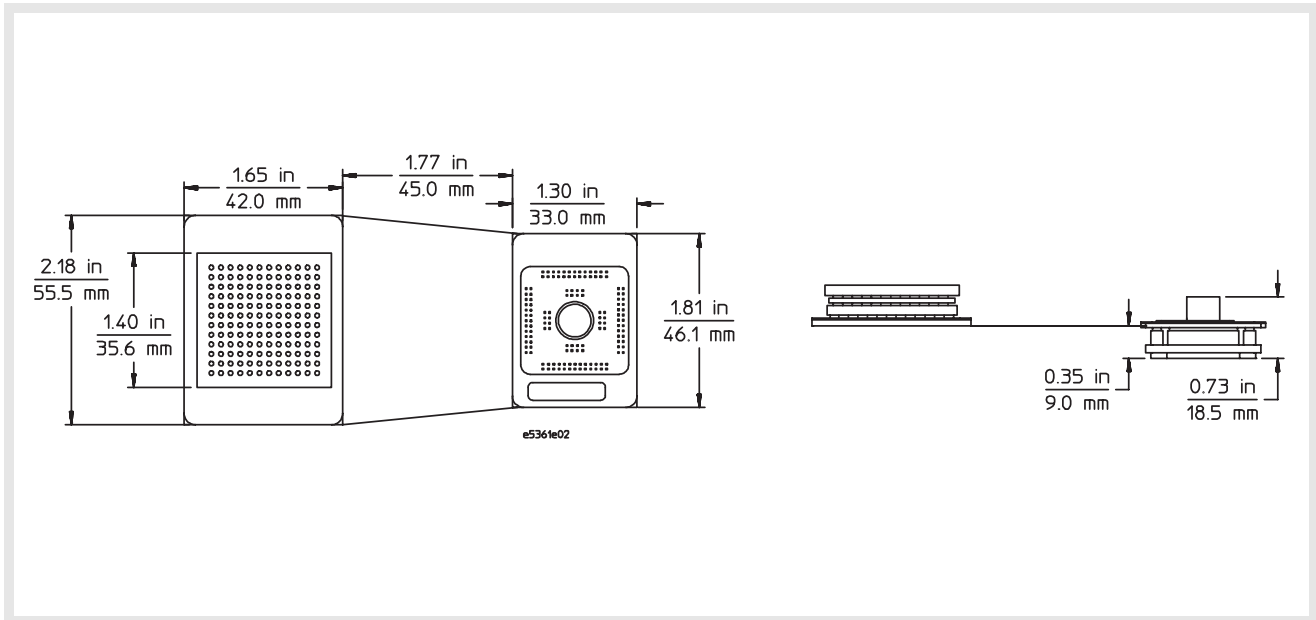

Figure 6

Required keepout area

- 1.58" (40.2mm) X 1.58" (40.2mm) square, centered over the C167 microcontroller
- Maximum height of components in the keepout area is 0.8mm

Dimensions for Probe

- 144-pin MQFP Adapter
Dimensions for HP E5613A
(HP P/N E5613-61620)

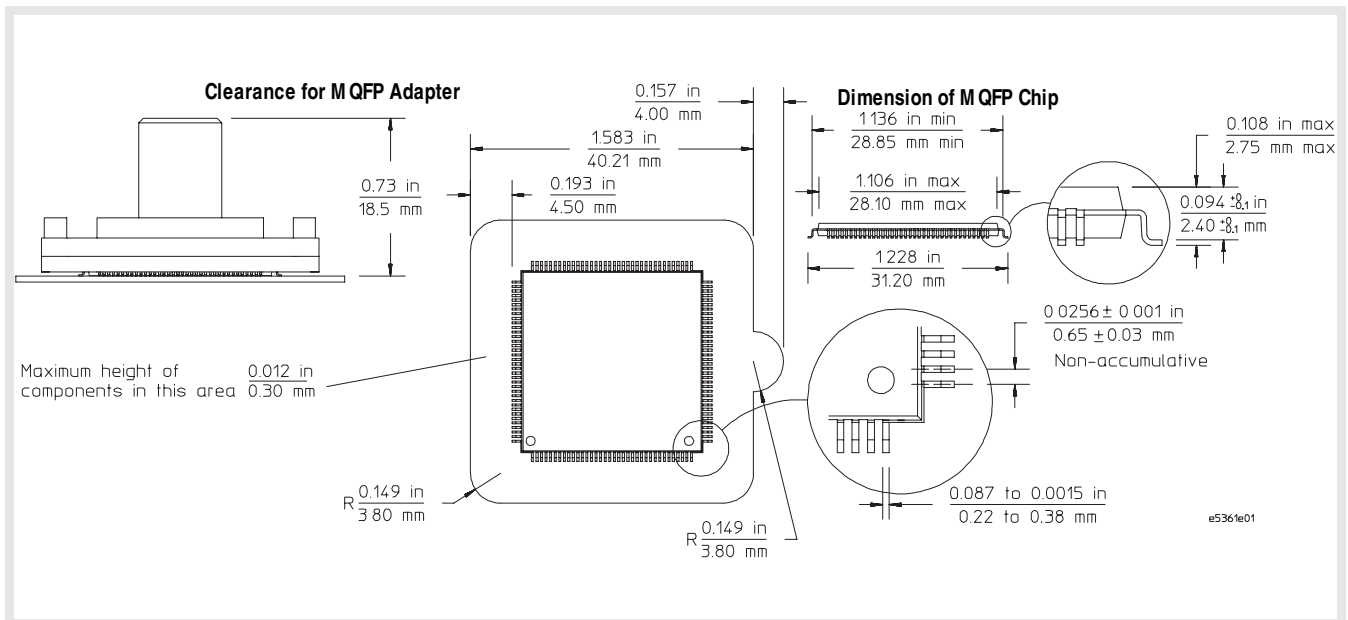

Ordering Information

Typical Configuration without Real-Time Trace Capability

- Model E3474A
- Description:
25-MHz emulation probe, run control unit, and E5361A 144-pin flexible cable and probing connection to SMT MQFP for Siemens C167 series of the Siemens 80C166 family of microcontrollers.

Related HP Literature

5964-9952E	<i>HP Distributed Emulation</i>
5964-9973E	<i>HP Distributed Emulation Flexibility for the Future</i>
5962-9887E	<i>HP B3740A Configuration Guide</i>
5962-7114E	<i>HP B3740A Software Analyzer Product Overview</i>
5965-3187E	<i>HP 16500C Logic Analysis and HP16505A Prototype Analyzer</i>
5964-3665E	<i>The HP 1660C/CS and HP 1670-Series Logic Analyzers,</i>
5964-9333E	<i>The HP B4620A Software Analyzer Tool Set,</i>
5962-7114E	<i>The HP B3740A Software Analyzer,</i>

Warranty Information

This Hewlett-Packard product has a warranty against defects in material and workmanship for a period of one year from date of shipment. During this warranty period, Hewlett-Packard Company will, at its option, either repair or replace products that prove to be defective.

For more information about Hewlett-Packard test & measurement products, applications, services, and for a current sales office listing, visit our web sites,
<http://www.hp.com/go/tmdir>
<http://www.hp.com/go/emulator>
<http://www.hp.com/go/logicanalyzer>

You can also contact one of the following centers and ask for a test and measurement sales representative.

United States:
Hewlett-Packard Company
Test and Measurement Call Center
P.O. Box 4026
Englewood, CO 80155-4026
1 800 452 4844

Canada:
Hewlett-Packard Canada Ltd.
5150 Spectrum Way
Mississauga, Ontario
L4W 5G1
(905) 206 4725

Europe:
Hewlett-Packard
European Marketing Centre
P.O. Box 999
1180 AZ Amstelveen
The Netherlands
(31 20) 547 9900

Japan:
Hewlett-Packard Japan Ltd.
Measurement Assistance Center
9-1, Takakura-Cho, Hachioji-Shi,
Tokyo 192, Japan
Tel: (81-426) 56-7832
Fax: (81-426) 56-7840

Latin America:
Hewlett-Packard
Latin American Region Headquarters
5200 Blue Lagoon Drive
9th Floor
Miami, Florida 33126
U.S.A.
(305) 267 4245/4220

Australia/New Zealand:
Hewlett-Packard Australia Ltd.
31-41 Joseph Street
Blackburn, Victoria 3130
Australia
1 800 629 485

Asia Pacific:
Hewlett-Packard Asia Pacific Ltd
17-21/F Shell Tower, Times Square,
1 Matheson Street, Causeway Bay,
Hong Kong
Tel: (852) 2599 7777
Fax: (852) 2506 9285

Technical information in this document is subject to change without notice