

---

# HP E1432A, HP E1433A and HP E1434A

## Product Overview

**A high-performance  
system architecture for  
demanding mechanical,  
acoustic and electrical  
test applications.**



# HP E1432A and HP E1433A Digitizer plus DSP

The HP E1432A 16-Channel 51.2 kSa/Sec/Chan digitizer and E1433A 8-channel 196 kSa/Sec/Chan digitizer integrate transducer signal conditioning, anti-alias protection, digitization, and high-speed

measurement computation in a single-wide VXI module. Onboard digital signal processing and up to 32 Mbytes of RAM maximizes total system performance and simplifies system integration.

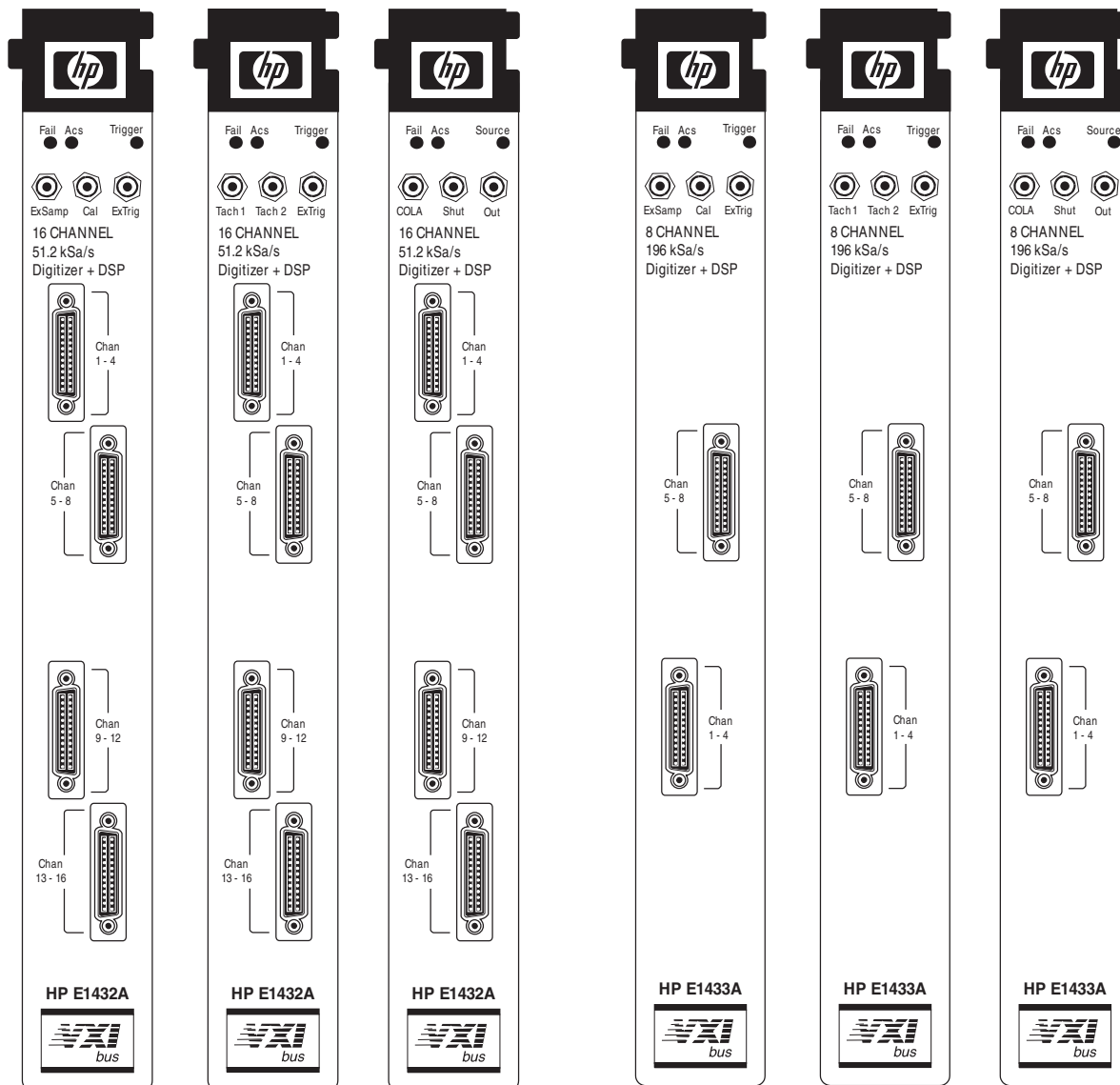

**HP E1432A**

**HP E1432A  
with  
Tachometer  
Option AYF**

**HP E1432A  
with  
Arbitrary  
Source  
Option 1D4**

**HP E1433A**

**HP E1433A  
with  
Tachometer  
Option AYF**

**HP E1433A  
with  
Arbitrary  
Source  
Option 1D4**

Onboard computation of measurement results, fast data transfer to the host computer, and a dedicated high-speed data bus for module-to-module communication provide a high-performance measurement architecture for demanding mechanical, acoustic, and electrical test applications.

### **Parallel Processing Architecture**

Multi-channel systems generate large amounts of data fast. This can overwhelm a host computer's data busses and computational capabilities. A parallel processing architecture increases performance by distributing computations over multiple processors, all performing their computations simultaneously (see figures 1 through 4 for the block diagrams of both the HP E1432A and HP E1433A digitizers.)

The HP E1432A and E1433A both use a floating point DSP processor to compute measurement results in the module. Computing measurement results onboard the HP E1432A and E1433A offloads computations from the host computer, preventing it from being a system performance bottleneck. This is especially important for large systems with many channels.

Adding more HP E1432A and E1433A digitizers to a system adds more DSP processing capability, maintaining system performance even for extremely large systems. For example, an 80-channel HP E1433A-based system has 10 floating point processors computing measurement results in parallel. This provides a level of performance unattainable in systems that rely on the host computer alone to compute measurement results.

### **Move Data Fast**

Once digitized data is processed, it must be moved to the host computer for display or further computations. The HP E1432A and E1433A provide very high data transfer rates to the host computer over the VXI bus so host computers can display information in real time. And, since the HP E1432A and E1433A can unload their information quickly, the VXI bus is not tied up, allowing other modules access to it.

### **Dedicated High-Speed Local Bus**

Applications such as throughput to disk require exceptionally high continuous data transfer rates to other VXI modules. VXI provides a dedicated "local bus" for such transfers. Since the local bus is dedicated to data only, its performance is unaffected by transfers between the host computer and other VXI modules. The HP E1432A can achieve a continuous (gapless) transfer of data over the local bus to an HP E1562E 8 GB SCSI data disk at 5 Msamples/sec (10 Mbytes/sec). Higher rates are achieved with multiple data disks. (See High Speed Data Capture section of this document.)

**Figure 1:**  
**HP E1432A**  
**4-Channel Digitizer**  
**Block Diagram**

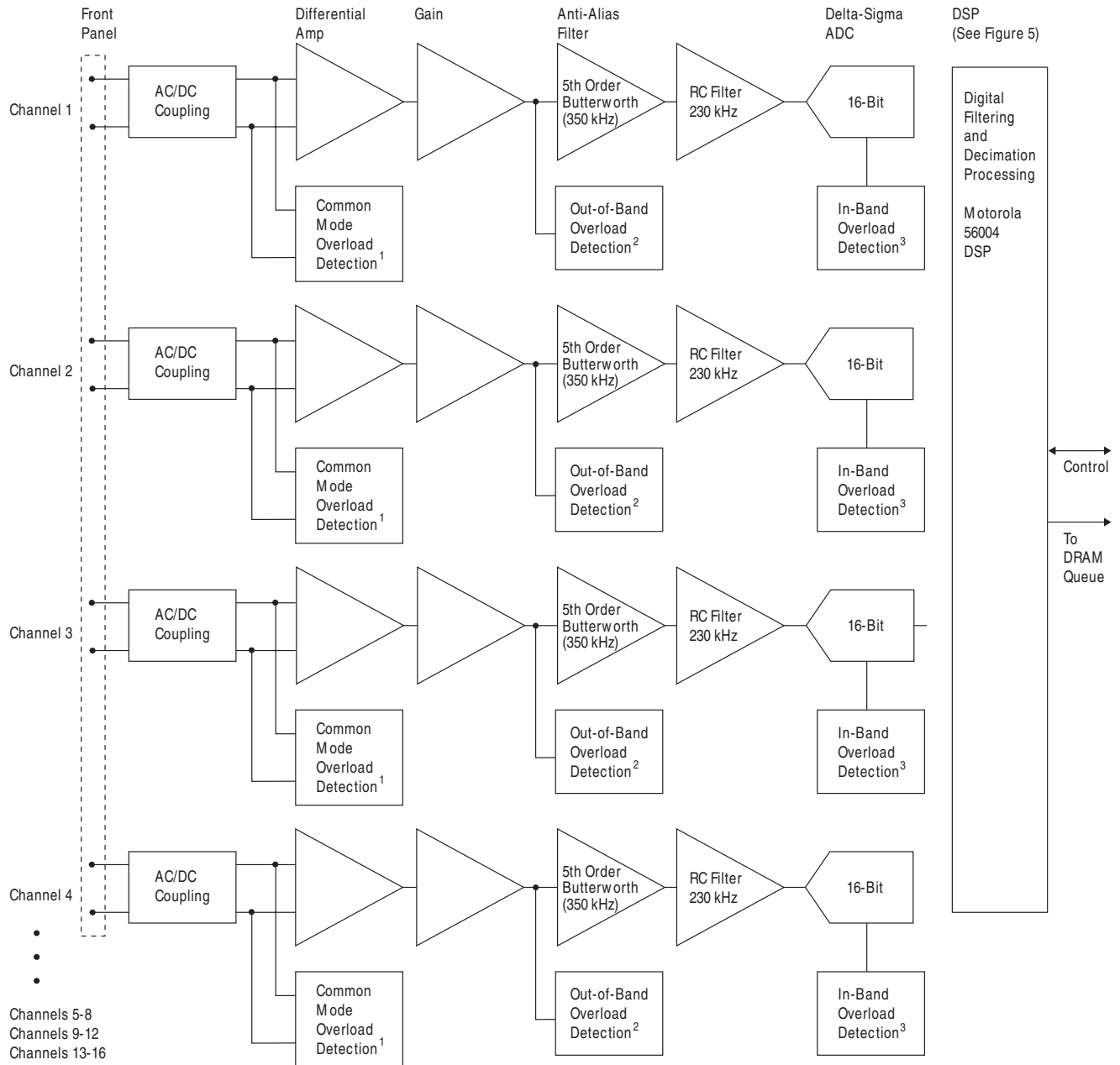

<sup>1</sup> Detects common mode overloads in differential amplifier.

<sup>2</sup> Detects signals which are more than 5 dB above selected input full scale range at all frequencies up to the MHz range.

<sup>3</sup> Detects a full scale overload for signals within the pass band.

**Figure 2:**  
**HP E1433A**  
**4-Channel Digitizer**  
**Block Diagram**

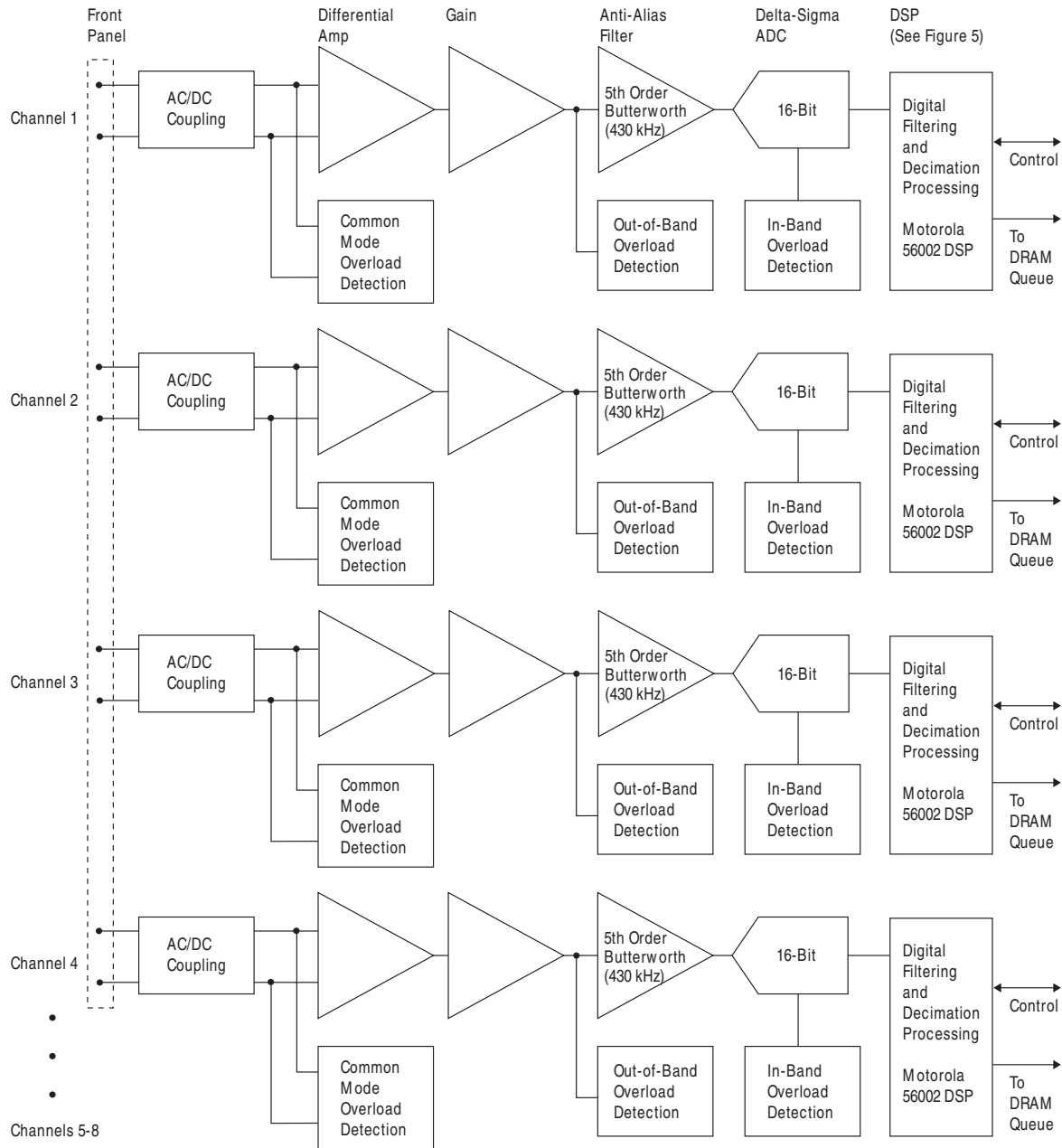

**Figure 3:  
HPE1432A  
Block Diagram**

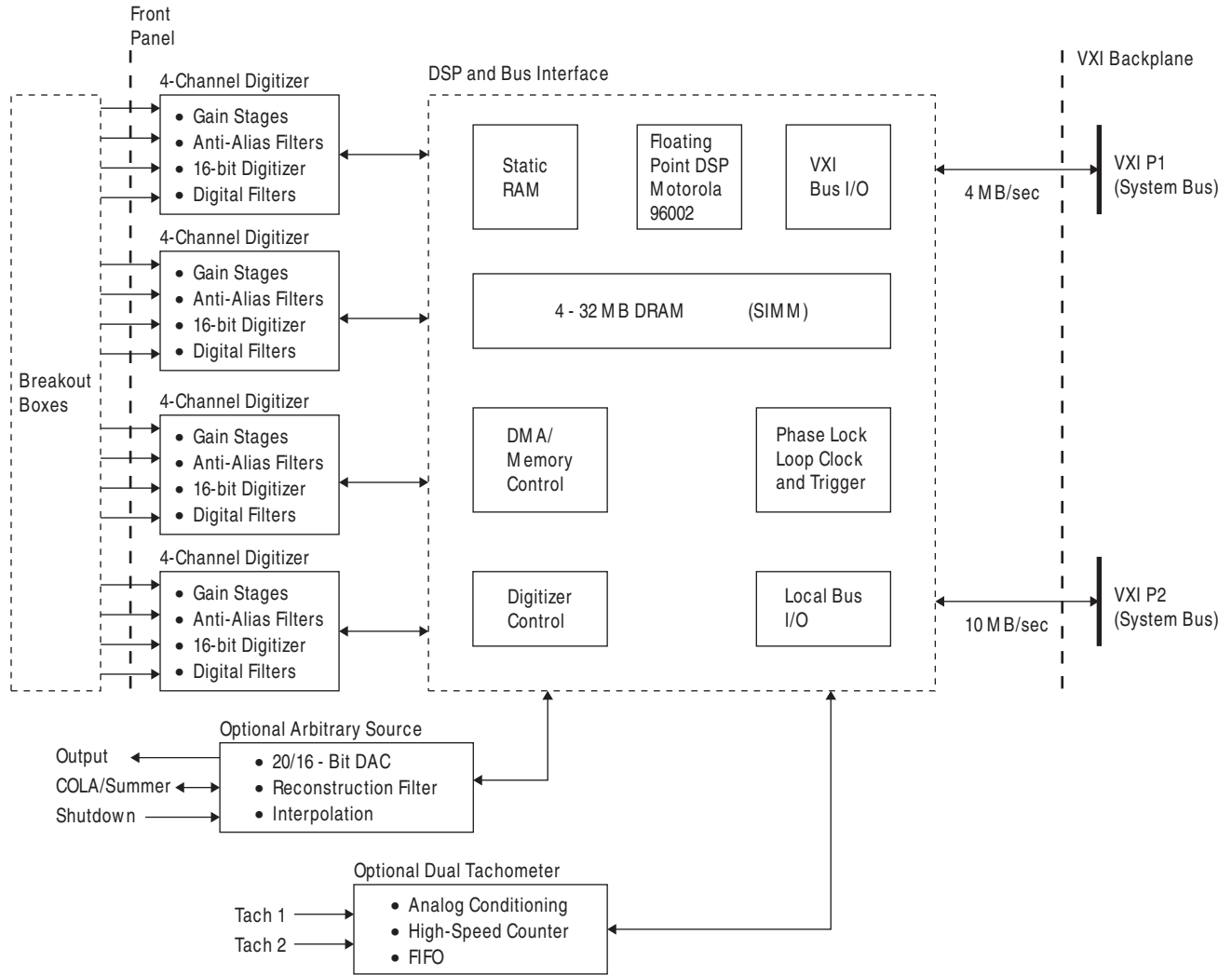

**Figure 4:  
HPE1433A  
Block Diagram**

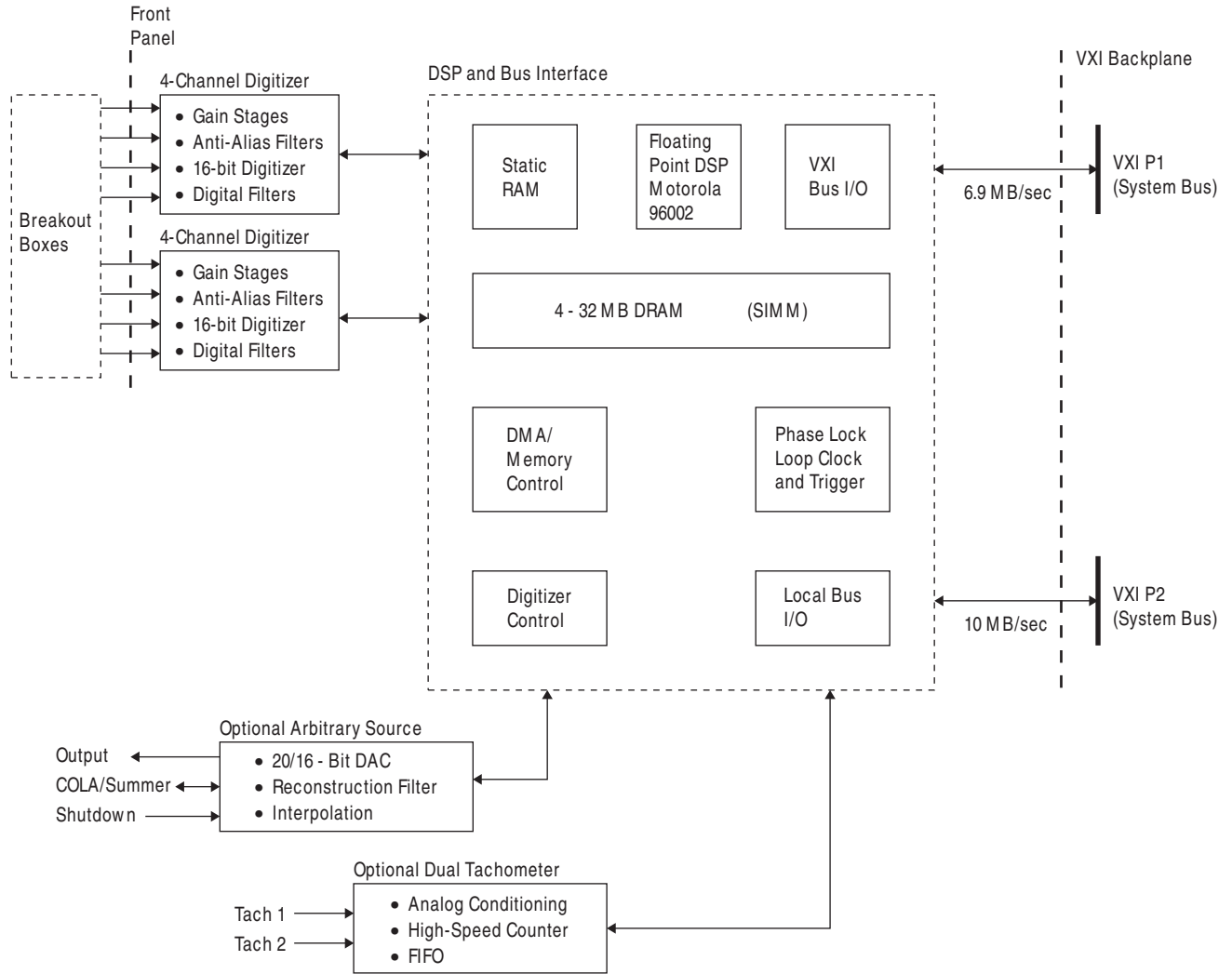

# HP E1432A and E1433A Hardware Architecture

The HP E1432A and E1433A provide transducer signal conditioning, anti-alias filtering, digitization, and measurement computation in a single module. System software development is easier because you just set up one module. And, even more importantly, you don't have compatibility issues between separate signal conditioning, filter, digitizer, and DSP modules. The specifications of the entire measurement channel are predictable. In fact, they're guaranteed.

## Signal Conditioning Breakout Boxes

The HP E1432A and E1433A use external breakout boxes to interface to voltage, Integrated Electronics Piezo Electric (IEPE) transducers, microphones, and piezoelectric charge transducers — the most common transducers used in mechanical, acoustic, and electrical test. Four different breakout boxes let you configure your system any way you want. All breakout boxes, from the most economical voltage input breakout box to models that support three kinds of transducers, can be used with either the HP E1432A or E1433A. Different types can be mixed together on a single digitizer module. (See figures 5-8.)

## Independent Input Channels

Each channel of an HP E1432A or E1433A has independent settings for:

- Range
- Differential/Single Ended
- AC/DC coupling

The HP E1433A is the higher-performance model of the two digitizers. It supports lower full-scale input ranges, higher sample rates and bandwidths, has extra features, and has tighter specifications than the more economical HP E1432A.

## HP E1433A Programmable Highpass Filters

Sometimes low-frequency noise components are larger than the signal you want to measure. Analog filters actually remove the signal so you can reduce the channel's full-scale range, maximizing dynamic range. But analog filters have poor channel-to-channel phase matching due to component tolerances and component drift over time and temperature.

Digital filters, on the other hand, have great channel-to-channel phase matching but, since they only filter the data after it has been digitized, they don't allow you to reduce the input range to increase dynamic range. The HP E1433A uses a novel programmable 12 dB/octave highpass filter that provides the benefits of both analog and digital filters. By implementing the highpass filter digitally, but using a DAC to implement an actual analog summing at the input, the HP E1433A achieves the best of both technologies.

Acoustical intensity measurements are an application where tight channel-to-channel phase match is critical. In applications such as wind tunnel acoustic measurements, the HP E1433A removes low-frequency noise but still provides excellent channel-to-channel phase matching.

## Simultaneous-Sampling Delta-Sigma ADCs

The HP E1432A and E1433A use an ADC per channel to avoid timing errors that often occur when a single ADC is multiplexed between multiple channels. Simultaneous sampling guarantees accurate channel-to-channel comparisons, both in the time and frequency domains. The HP E1432A and E1433A's delta-sigma ADCs use 64X over-sampling, allowing low-order analog anti-alias filters. Since the anti-alias filters corner frequencies are far above the channel's passband, the analog filters don't degrade performance in the passband.

## Programmable Digital Anti-Alias Filters

Aliased frequency products degrade measurement accuracy. Without good anti-alias filters, you can't trust your data. All filtering and sample-rate conversion in the HP E1432A and E1433A are done digitally, providing stable, drift-free filtering. This provides flat passbands and guaranteed -90 dB alias rejection down to very low sample rates — 10 Hz for the HP 1432A and 1.9968 Hz for the E1433A. See Figures 9 and 10 for the available sample rates and digital filter frequencies.

**Figure 5:**  
**HP E3240A 8-Channel Voltage Breakout Box**  
 The HP E3240A is the most economical breakout box providing eight BNC connectors for interfacing to voltage signals.

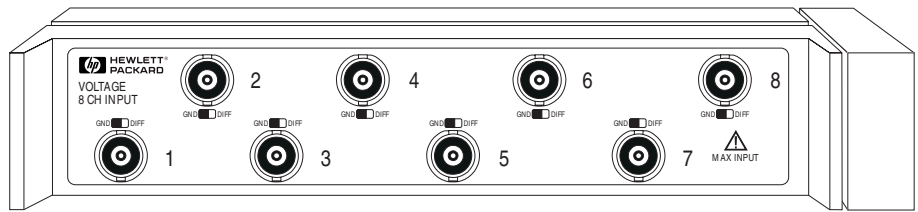

**Figure 6:**  
**HP E3241A 8-Channel Voltage/Breakout Box with IEPE Power Supply**  
 The HP E3241A is identical to the E3240A with the addition of a software-switchable IEPE power supply.

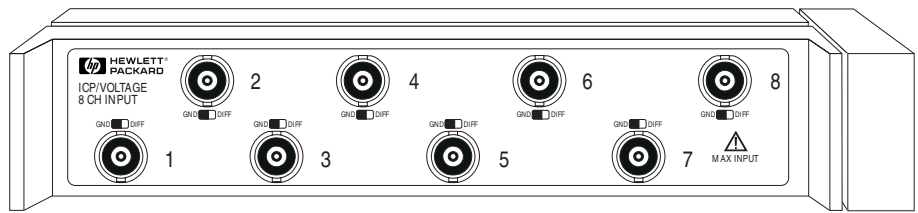

**Figure 7:**  
**HP E3242A 4-Channel Charge/Voltage Breakout Box**  
 The HP E3242A provides a charge amplifier for signal conditioning of piezoelectric transducers which are typical of many accelerometers. The HP E3242A also provides a voltage and an IEPE power supply.

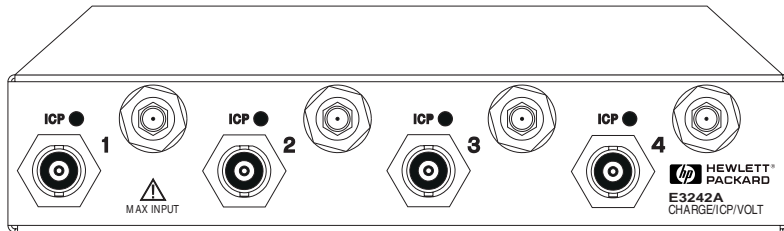

**Figure 8:**  
**HP E3243A 4-Channel Microphone/Voltage Breakout Box**  
 For acoustic applications, the HP E3243A provides signal conditioning for microphones and also provides a voltage mode and an IEPE power supply.

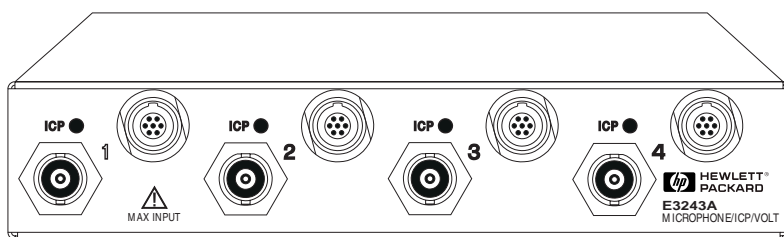

Note:  
 For custom signal conditioning situations, the voltage mode is available by direct connection to the module front panel connector.

**Figure 9:**  
**HP E1432A**  
**Digital Filtering**  
**and Decimation Processing**

**9 Decimate-by-2 Filter Stages**

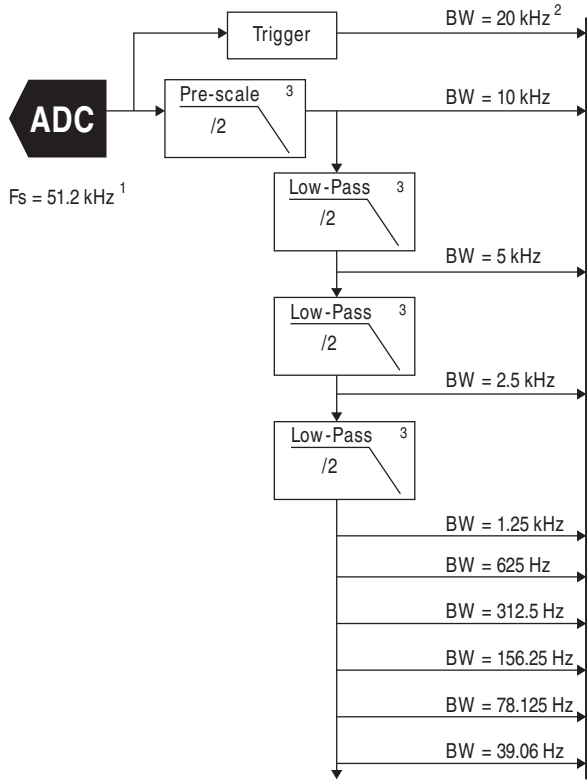

**Decimate-by-5 with 9 Decimate by 2 Filter Stages**

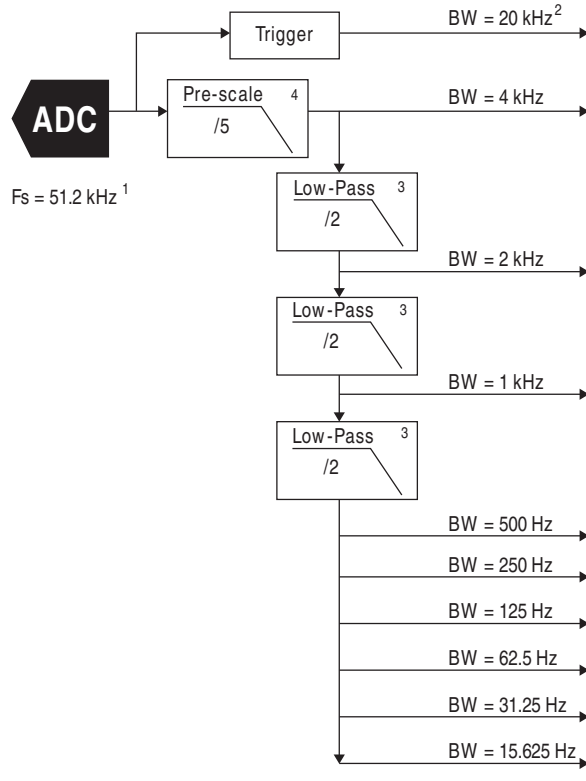

**Zoom Digital Filtering**

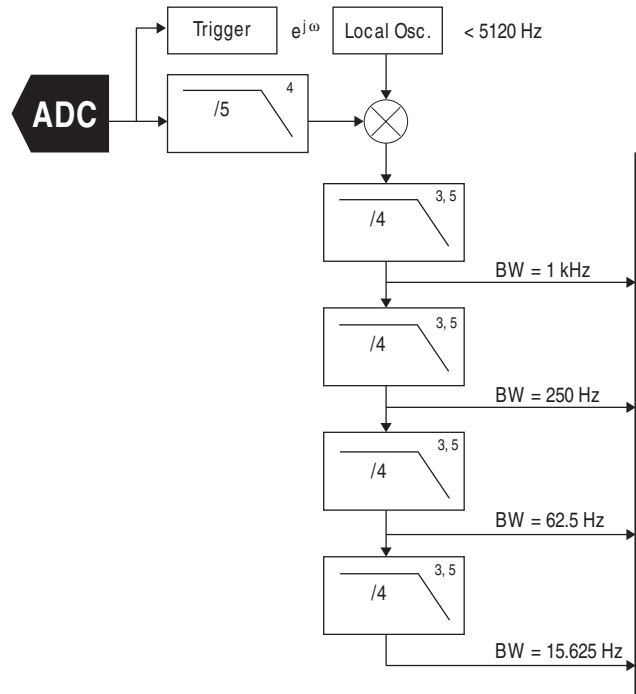

<sup>1</sup> Fs can be programmed to  
 51.2 kHz    39.0625 kHz    31.250 kHz  
 50 kHz    38.4 kHz    30.72 kHz  
 49.152 kHz    33.333 kHz    or 26.4 kHz  
 48 kHz    32.786 kHz  
 40.96 kHz    32.000 kHz  
 If an external Fs is used, it must be  
 a fixed frequency between 26.4 kHz  
 and 65 kHz.

<sup>2</sup> 20 kHz represents 400 lines of  
 512-line spectrum. Before the first  
 filter stage, 460 lines are actually  
 accurate, giving 23 kHz maximum  
 useable bandwidth.

<sup>3</sup> 8th order elliptic.

<sup>4</sup> 10th order elliptic.

<sup>5</sup> Filters complex data

**Figure 10:**  
**HP E1433A**  
**Digital Filtering**  
**and Decimation Processing**

**12 Decimate-by-2 Filter Stages**

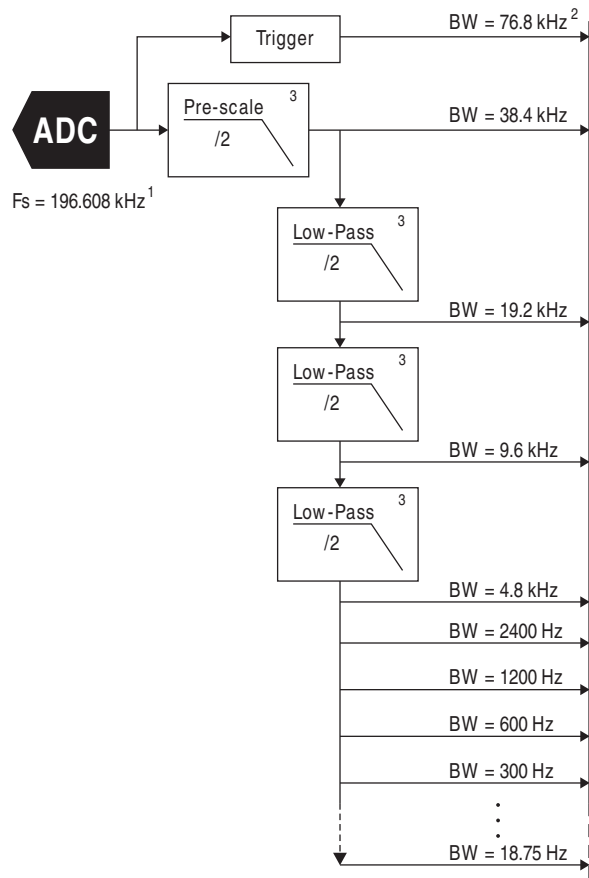

**Decimate-by-5 with 17 Decimate by 2 Filter Stages**

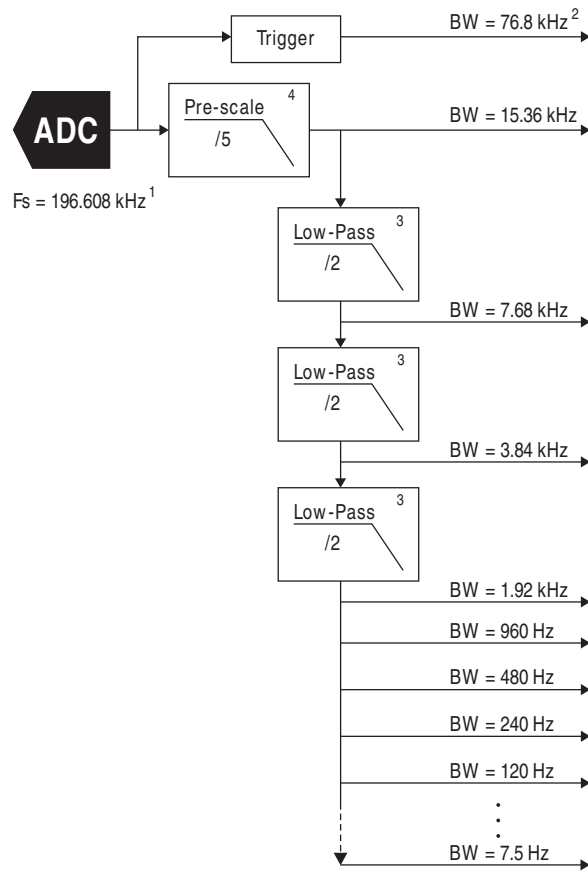

Note: Decimation only available for  $F_s$  100kHz and below.

<sup>1</sup>  $F_s$  can be programmed to

196.608 kHz	102.4 kHz	64.0 kHz
192.00 kHz	100.0 kHz	62.5 kHz
163.84 kHz	98.304 kHz	61.44 kHz
163.84 kHz	96.0 kHz	52.4009 kHz
156.25 kHz	81.92 kHz	51.2 kHz
153.6 kHz	80.00 kHz	50.000 kHz
133.333 kHz	78.125 kHz	49.152 kHz
128.0 kHz	76.800 kHz	48.000 kHz
125.0 kHz	66.666 kHz	44.1221 kHz
122.88 kHz	65.536 kHz	41.9386 kHz
		or 40.96 kHz.

If an external  $F_s$  is used, it must be a fixed frequency between 40.96 kHz and 200 kHz.

<sup>2</sup> 78.6 kHz represents 400 lines of 512-line spectrum. Before the first filter stage, 460 lines are actually accurate, giving 88.32 kHz maximum useable bandwidth.

<sup>3</sup> 8th order elliptic.

<sup>4</sup> 10th order elliptic.

### **Zoom for More Detail with the HP E1432A**

If you are only interested in the frequency range from 1000 to 2000 Hz, for example, why waste lines of resolution at other frequencies? Use zoom processing to put all frequency lines of the FFT in that range, focusing attention on the frequencies of interest.

The zoom spans available in the HP E1432A are 1 kHz, 250 Hz, 62.5 Hz and 15.625 Hz with the center frequency less than 5120 Hz.

### **Onboard RAM Buffers**

After data is digitized and filtered it is moved to circular RAM buffers, one buffer for each active channel. The buffers, combined with versatile pre- and post-triggering capabilities, make it easy to capture exactly the signal you want. To capture transients to onboard RAM, program the buffer size to the total number of samples you want to collect. Then set the amount of pre-trigger delay you want. Data will circulate through the buffers until the trigger occurs. The HP E1432A and E1433A will then freeze the pre-trigger information in the buffers and continue collecting data until the desired total amount of data has been collected.

If you want to continuously acquire data to the host computer, the buffers can interrupt the host when they are half full. The host

can then unload the buffers without effecting the ongoing data acquisition. Using these techniques, continuous data acquisition can proceed indefinitely. The only limitation is the rate at which data can be transferred to the host.

For very large acquisitions at very high rates, use the local bus to transfer data to an HP E1562E 8 Gbyte SCSI Data Disk. (See HP Publication 5964-3716E, and 5963-9643E.)

### **Onboard Measurements**

A floating point processor copies data from the RAM buffer to its SRAM buffers for measurement computations. By computing FFTs, power spectrums, and order ratio analysis, it offloads work from the host processor. (See figure 11 for the HP E1432A data flow diagram.) It also creates a parallel processing architecture, allowing simultaneous processing in the host computer and each HP E1432A and E1433A.

### **Two Highspeed Busses**

The floating point processor can move data to the host computer over the VXI bus, or to another VXI module over the local bus. Or do both simultaneously. This allows the HP E1432A and E1433A to capture time data over the local bus to an HP E1562D/E Data Disk while also sending this time data (or computed FFTs of the

acquired data) to the host over the VXI bus for monitoring the throughput process.

### **Optional Tach and Source**

Two important options significantly enhance the HP E1432A and E1433A's capabilities. A tachometer input allows tight integration of tachometer information from rotating machinery with digitized data from the input channels. This provides the information the floating point processor needs to do RPM triggering of measurements, and order analysis measurements. (see Built-in Measurement section on page 14.) Since the tachometer is integrated with the digitizer, no host involvement is required for this functionality.

Instead of the tachometer you can add an optional 16-bit arbitrary source. Its sine, random, and arbitrary waveforms provide excitation for stimulus/response testing. Again, tight integration of the source with the input channels and floating point processor simplifies testing since the host computer is not involved in controlling the measurement, the source DAC and ADC. The host is also relieved of computing many measurement results (windowing, FFT's, revolution domain resampling, etc).

**Figure 11:**  
**HP E1432A**  
**DSP Data Flow**  
**(HP E1433A similar)**

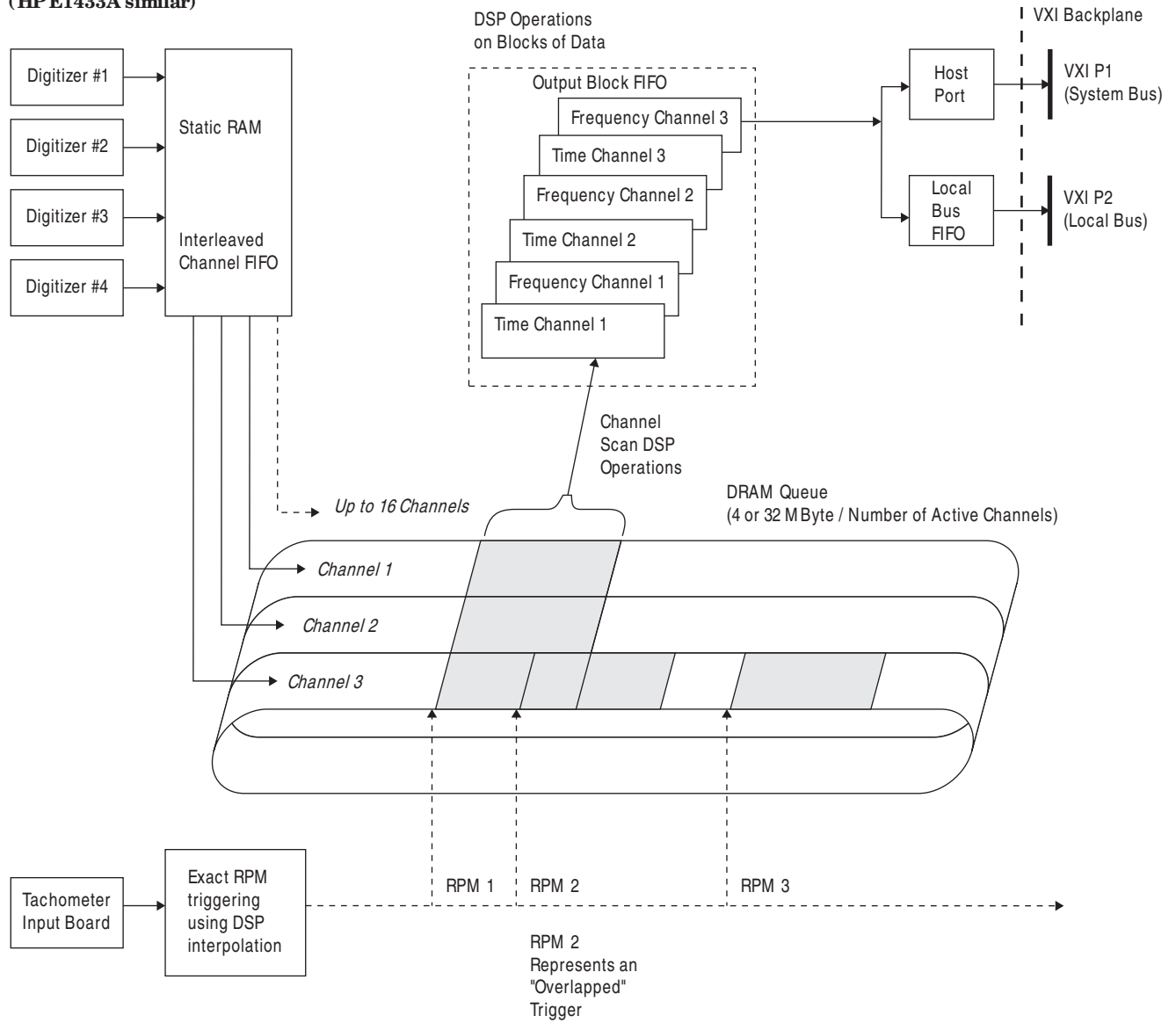

# Built-In Measurements in Four Domains

The HP E1432A turns data into information by providing data in whichever domain offers the most insight — time, frequency, angle, or order. See figure 12 for a description of the four data domains.

## Time Domain

The most common data type for digitizers is time domain. Since the HP E1432A and E1433A use simultaneous sampling, time relationships between signals are preserved, allowing accurate channel-to-channel comparisons.

## Frequency Domain

Examining signals in the frequency domain allows you to resolve very small signals in the presence of large signals. The HP E1432A and E1433A use onboard DSP to compute windowed FFTs and averaged power spectrums. Averaging further improves your ability to see down into the noise. Several averaging types are supplied, including overlap processing.

The high performance of parallel processing is achieved without requiring any user programming.

## Angle or Rotation Domain

Analyzing noise or vibration from rotating machines may require signal sampling to be synchronized to a shaft's rotational velocity.

Adding Option AYW tachometer input lets you measure amplitude as a function of shaft angle, with fractions of a degree resolution. To further decrease noise, you can average multiple revolutions of the shaft.

The HP E1432A and E1433A avoid the inaccuracies and cost of the tracking filters and ratio synthesizers commonly used to make these measurements by computing the values in DSP. The floating point processor uses accurately measured tach times from the tachometer input to compute the actual values. Alias protection is guaranteed and errors associated with settling times of analog tracking filters and stability of ratio synthesizers are avoided.

## Normalized Order Domain

Knowing the order, phase, and amplitude of signal components can be a great diagnostic tool in determining the cause of undesirable vibrations or noise in a rotating machine. The order domain provides the advantages of the frequency domain, but with all frequencies normalized to the shaft rotational velocity.

For example, to characterize the vibration of a rotating machine over its entire operating range of RPMs, choose a start RPM, stop RPM, and RPM interval. The tachometer input will trigger a set of order ratio spectrums to be measured at the selected RPMs during the machine's run-up or run-down. Onboard computations and automatic buffering of

acquired data allow very fast run-ups and run-downs without missing data.

## Optional Tachometer Input (Option AYW)

The optional tachometer input is required for angle and order domain analysis, but it has other uses. It provides RPM triggering of data acquisitions of all types — time, frequency, angle, or order. Data acquired can be stamped with the RPM at which it was acquired. This optional tachometer input also provides a more flexible external trigger capability for either the HP E1432A or E1433A.

## Optional Arbitrary Source (Option 1D4)

If your device-under-test requires excitation, the 16-bit arbitrary source option can provide stimulus to a shaker, loudspeaker, or electrical device. It saves money because it doesn't require an extra slot in the mainframe, and its trigger options make it easy to create systems for doing stimulus/response testing.

The 1D4 option is equivalent to channel 1 of the HP E1434A 4-channel 65kSample/sec arbitrary source. (See the HP E1434A section on page 16 for more information about the source option.)

**Figure 12:**  
**HP E1432A**  
**Data Domains**

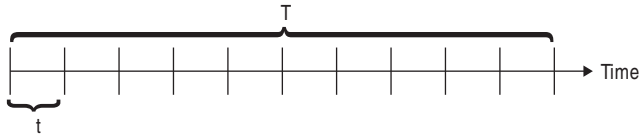

Constant Time Sampling

Time Domain	Frequency Domain (FFT)
$t = \text{Time Resolution}$	$\frac{1}{2.56 * t} = \text{Maximum Frequency}$
	$\frac{1}{T} = \text{Frequency Resolution}$

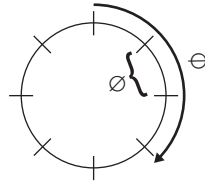

Constant Angle Sampling (Synchronous Sampling)

Angle Domain	Order Domain (FFT)
$\text{Ø} = \text{Angular Resolution}$	$\frac{1 \text{ Revolution}}{2.56 * \text{Ø}} = \text{Maximum Order}$
	$\frac{1 \text{ Revolution}}{\text{Ø}} = \text{Order Resolution}$

\* 2 for Nyquist,  
 but 2.56 for a  
 realizable  
 anti-alias filter.

# High-Speed Data Capture

The HP E1432A and E1433A have multiple ways to record high-speed transients. Signals can be captured to onboard RAM, continuously sent to the host via the FIFO RAM buffer, or sent over the local bus to the HP E1562D/E SCSI Data Disk or other modules supporting local bus (HP E1485A).

## Onboard RAM FIFOs

The HP E1432A and E1433A come standard with 4 MB of RAM. It can be increased to 32 MB RAM with the option ANC. Since there are 2 bytes per sample, this represents 16 Msamples of data. This RAM is evenly divided between the number of active channels. Digitized data flows into the RAM and can be read out to the host computer. If the data rates are not too fast, the host can read out the data continuously, without interrupting the measurement.

For very fast data rates, the RAM can be used to buffer the data for the host to read when the measurement is completed. Another method supported is to configure the buffer as a FIFO. This will allow the host to read out continuous data until the FIFO overflows. If the host is fast enough, the FIFO will never overflow. If the host can't read the FIFO fast enough, the FIFO will eventually overflow and the measurement will stop; however, the accumulated data can be read out at this time. You can also configure the RAM as a circular buffer that continually overwrites itself. This is useful if you want to capture the events that precede the trigger. Data will continually fill the

buffer until the trigger occurs. The RAM will then save the pre-trigger data and continue taking data for the programmed amount of time.

## Throughput to HP E1562D/E Data Disk

The VXI local bus provides a high-speed path to the HP E1562D/E SCSI Data Disk. Two versions are available, the 4 Gbyte HP E1562D with built-in 4 Gbyte DAT drive, or the 8 Gbyte E1562E without the DAT. The HP E1562E can capture data at a rate of greater than 5 Msamples/s (10 Mbytes/s) for the complete 8 Gbytes, with no gaps or glitches.

Using only the first 40% of the HP E1562E disks, the HP E1432A or the E1433A can achieve 7.5 Msample/s (15 Mbytes/s) sustained. Adding an HP E1562F to the HP E1562E, will allow sustained transfer rates of 7.5 Msample/s for all 17 Gbytes of disk space.

A system with one HP E1562E and one HP E1562F can sustain data transfers for 144 channels of HP E1432A's with each channel sampling at 51.2 kSa/s rate. For HP E1433A's, 40 channels at 196 kSa/s can be sustained using all 17 Gbytes of disk space.

## Monitor While Throughputting Data

Both the HP E1432A and the E1433A can throughput data to the E1562D/E via the local bus while at the same time, send a portion of this data over the slower VME bus to the host computer for monitoring purposes. The monitored data sent to the host can be either time data, frequency domain (FFT) or order data. This monitoring capability assures you that the data being recorded on the HP E1562D/E is valid.

# HP E1434A 4-Channel 65kSample/Sec Arbitrary Source

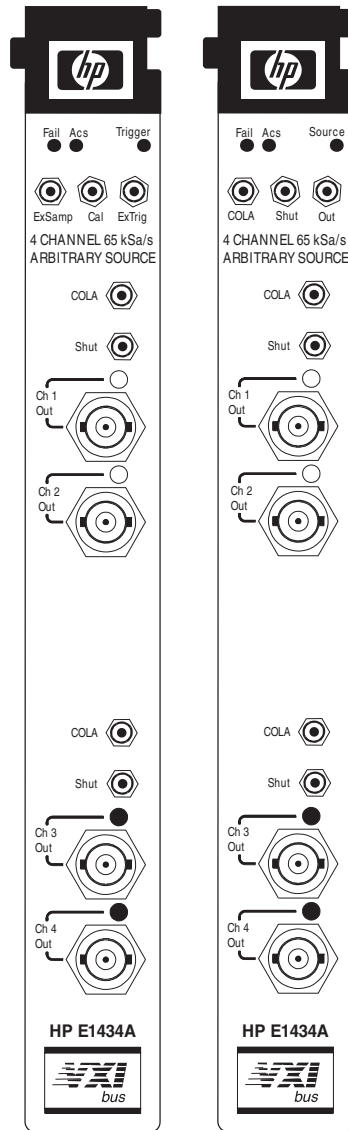

HP E1434A

HP E1434A  
with Option  
1D4

The HP E1434A 4-Channel 65 kSamples/sec Arbitrary Source combines on-board creation of common waveforms with continuous arbitrary waveform playback to enhance ease of use and increase system performance compared to typical DAC architectures that have little built-in intelligence. The versatile waveform types and performance coupled with the HP E1434A's tight integration with both the E1432A and E1433A digitizers make it the ideal source for multi-channel stimulus-response measurements in both mechanical and electrical applications.

A single-channel version of the HP E1434A is available as an internal option to the E1432A and E1433A digitizers.

## Four Source Channels at 65 kSamples/Sec

The HP E1434A module provides 2, 4 or 5 arbitrary source channels. It provides four channels when run in the 16 bit, 65536 kSample/sec mode. This mode provides up to a 25.6 kHz bandwidth (also referred to as Span). A fifth source channel can be added to the HP E1434A with Option 1D4

For applications not needing four channels option 1DM can be ordered to delete two source channels.

## Common Waveforms Computed Internally

Built-in sine and random noise waveforms save development time and offload computations and data movement chores from the host computer. Multiple source channels can be programmed to output uncorrelated random noise, or each source channel can output the exact same random sequence.

The same versatile synchronization and triggering capabilities are available in both the HP E1434A and option 1D4. Since the HP E1434A is a separate module there is some additional flexibility from that offered by option 1D4. For instance, the input channels on an HP E1432A can be re-initialized without impacting the E1434A's current state.

## Multiple Source Applications

In applications like Multiple-Input-Multiple-Output (MIMO) frequency response measurements or Structural Normal Mode testing, the number of sources (DACs) can easily be four or more. Also, in applications where large channel counts are needed for measured responses, the needed sources can be obtained either by adding an option 1D4 to each HP E1432A (or E1433A), or HP E1434As can be used to accomplish the same purpose.

**Figure 13:**  
**HP E1434A**  
**Block Diagram**

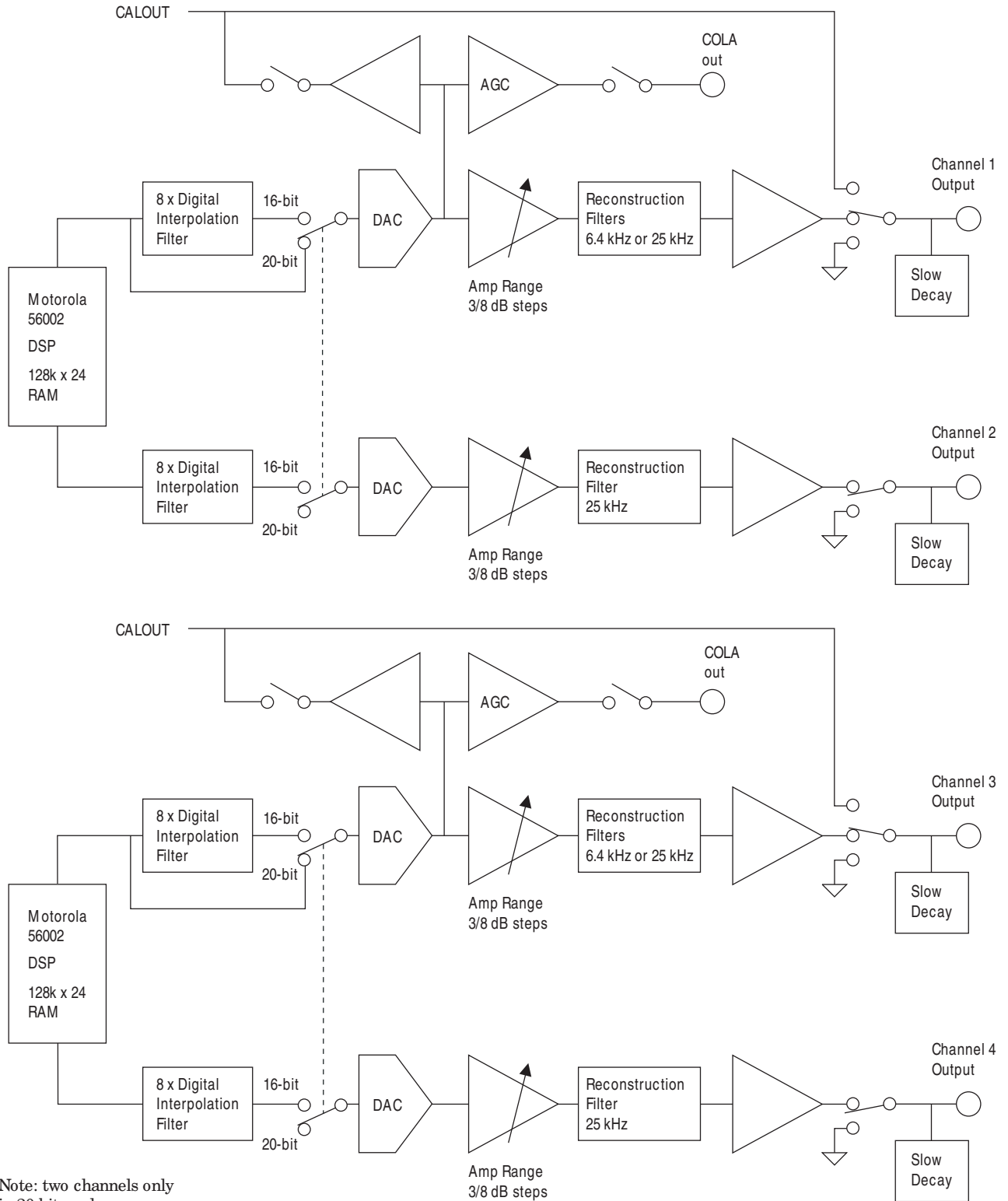

Note: two channels only  
in 20 bit mode.

## **High-Performance Architecture**

Most simple DACs require the host computer to create waveforms and then download them to the DAC. By computing its own sine and random noise waveforms, the arbitrary source option offloads work from the host computer, preventing it from becoming a system performance bottleneck.

Both the HP E1434A and option 1D4 address this need.

## **Sine and Noise Waveforms**

Sine waves are one of the most common test waveforms. Sinewaves can be continuous or burst waveforms, with frequencies from near zero to 25.6 kHz.

Uncorrelated and correlated noise waveforms are also available. The source provides pseudo random waveforms, in either continuous or burst mode. Different preprogrammed seeds (256) can be sent to each source to guarantee that each source's random output is uncorrelated with any other source in the system (or they can have the same seed which will cause the random output to be identical in each source).

Additionally, the source can band-translate the noise to have a non-zero start frequency. This allows you to pinpoint the noise stimulus to frequencies of interest, avoiding troublesome resonances or frequencies that might damage the device under test. This band-translate capability allows the source to have a bandwidth and

center frequency that matches the zoom FFT bandwidth and center frequency, creating a much higher quality measurement.

## **Arbitrary Waveforms**

Use arbitrary waveforms to provide almost any stimulus you can imagine. Arbitrary waveforms are supported in both option 1D4 and the HP E1434A.

## **Variable Resolutions**

The arbitrary source can be used as a 16-bit source with 25.6 kHz bandwidth, or as a 20-bit source with 6.4 kHz bandwidth.

The two modes are selectable by software. The 20-bit mode is useful for applications where the extra head room allows smooth output level changes over a wide amplitude range. In the HP E1434A, the 20-bit mode reduces the available channels per module from four to two (see E1434A block diagram).

## **Safety Features**

Since arbitrary sources can drive very expensive devices under test, it is important to provide an orderly shutdown in case of emergency. In addition to programmable ramp-up and ramp-down rates, the arbitrary source has a smooth ramp-down from AC power failure, or in response to its emergency shutdown input.

# VX|plug&play Library Functions

## Software Support

Software support for the HP E1432A, 1433A and E1434A is very comprehensive, allowing the utmost in flexibility and performance. The VX|plug&play library supporting the module has a companion component that is downloaded the first time the module is used after a system powerup or reset.

This downloading feature allows the module to remain current with changes in operating systems, new software features and bug fixes. The most current revision of this library is always available at no cost to the user by an anonymous ftp connection to a Hewlett-Packard server .

## High Performance

The VX|plug&play host library offers high-performance data movement and DSP computations within the module. In the case of the HP E1432A, up to six modules, with 16 channels each (96 channels total) running at 51.2 kSamples/sec/channel can write their data to a local bus in real time. This is an aggregate rate of 9.38 Mbytes/sec continuously. The HP E1433A can achieve comparable rates.

From a DSP performance perspective, the HP E1433A can be set up to compute FFTs on each channel and at the completion of 16 averages at a block size of 2048, upload these FFT results to an HP V743 host and stay real time at a 20 kHz bandwidth (51.2 kSa/sec/ch) for a total of 48 channels (6 HP E1433A modules). There is a great deal of flexibility here. You can upload each time history along with each FFT average, change the number of averages, change the window type, etc.

## Multiple Platforms Supported

The VX|plug&play host libraries for the HP E1432A, E1433A and E1434A are supported in HP-UX 9.X and 10.2 both with the embedded HP V743 host computer and external HP Series 700 computers via the MXI interface. Software environments such as HP VEE, MathWorks MATLAB, C, and C++ are supported.

For personal computers (PCs), the library supports both Win95 and WinNT™ environments on both embedded (HP E6232A, E6233A) and external hosts. Software environments such as HP VEE, MathWorks MATLAB, Microsoft C, C++ and Microsoft Visual Basic are supported. Contact your local HP representative

for the current support matrix.

## Full Featured

The VX|plug&play library contains more than 350 functions to extract the most in performance and flexibility from the modules. This library allows the HP E1432A/33A/34A to turn data into information by providing data in whichever domain offers the most insight — time, frequency, angle, or order.

The next section lists the functions available in a hierarchical grouping. Most functions have both a “set” and “get” version. The set function, like setRange, allows a single channel (or group of channels) to have the full scale range set. The get function interrogates the current setting. For instance, suppose you setRange to 8.5 volts. The setRange function knows that there is no full scale range of 8.5 volts, and sets the full scale value to the next higher valid range. The get Range would return a value of 10 volts in this example, since 10 volts is the next higher range. Most all functions also have a default setting, so if no “set” is called a default value is used and can be interrogated by the get function.

## Control HP E1432A/ E1433A/ E1434A Directly from Mathworks's MATLAB

If you are one of the more than 400,000 users of MATLAB and would like to directly control HP's high performance multi-channel digitizers and source modules, HP is now supplying this control capability as part of its standard Plug & Play library for the HP E1432A, HP E1433A and

HP E1434A VXI modules. The combination of MATLAB 5.0's n-dimensional arrays, matrix math, color surface shaded 3-D graphics, user interface building tools and HP's high performance measurement hardware provide most impressive results with a minimum of programming effort. This environment is really the "measurement engineer's programming language" that quickly turns measurements into insight.

## Simple for Simple Tasks

HP's Plug & Play library for the HP E1432A makes controlling the hardware easy for simple data acquisitions tasks. Setting up the module to acquire time data on 4 active channels onboard the E1432A card at a specific sample rate and full scale range and then uploading a 1024 block of samples for each channel to the host for plotting is accomplished with the

**Figure 14:**  
Matlab example program using Plug & Play Library calls to the HP E1432A

```
% Simple Matlab example of a four channel measurement
% This runs continuously , updating the display until stopped with "Control C"

BLOCKSIZE = 1024           % Number of samples obtained per channel when triggered
OLDCHANNELS = [1 2 3 4 5 6 7 8] % Make this variable 1 thru number of hardware channels that exist
CHANNELS = [1 2 3 4]      % Number of active channels in new measurement
SPAN = 20000.             % Variable for the alias-free frequency span (sample rate divided by 2.56)
RANGE = 10.0              % Full scale input voltage range variable

[status,session] = hpe1432('init','VXI0:8-INSTR:1.1');
% Initialize E1432 module at address 8 and return the session virtual
% instrument 'session'

[status] = hpe1432('deleteAllChanGroups',session);
% House cleaning to delete all previous channel groups

[status,gid] = hpe1432('createChannelGroup',session,length(OLDCHANNELS),OLDCHANNELS);
% Create a group of all
% channels. NOTE that the channel id for this group of channels is returned
% as gid (group ID)

[status] = hpe1432('setActive',session,gid,'CHANNEL_OFF'); % Turn all channels off

[status] = hpe1432('deleteAllChanGroups',session); % Delete all channel groups

[status,gid] = hpe1432('createChannelGroup',session,length(CHANNELS),CHANNELS);
% Create a group of four active channels

[status] = hpe1432('setBlockSize',session,gid,BLOCKSIZE); % set the block size for all channels

[status] = hpe1432('setRange',session,gid,RANGE); % Set full scale voltage range

[status] = hpe1432('setSpan',session,gid,SPAN); % Set alias protected span ( sample rate / 2.56 )

[status] = hpe1432('setDataMode',session,gid,'BLOCK_MODE'); % Place module in block acquisition mode

[status] = hpe1432('setAutoTrigger',session,gid,'MANUAL_TRIGGER');
% Setup trigger mode

[status] = hpe1432('initMeasure',session,gid); % start data acquisition

A=1;
while A>0,

[status] = hpe1432('triggerMeasure',session,gid,'NO_WAIT_FLAG');
% Trigger a block of data on all channels
[status,data,count] = hpe1432 ('readFloat64Data', session,gid, 'TIME_DATA',
BLOCKSIZE*length(CHANNELS),'WAIT_FLAG');
% transfer all four channels of time data with 1024 samples (blocksize)
% per channel

plot(reshape(data,BLOCKSIZE,length(CHANNELS))), drawnow;
% convert linear array of data into 2D matrix ( channels versus samples)
% and plot results

A=A+1 % let user know the loop is working
end

[status] = hpe1432('close',session);
```

**Figure 15:**  
The on-line help text for each function is very useful when actually creating your measurement program. Shown here is an example of the help text for the setRange function.

```
hpe1432_setRange

Syntax:
    ViStatus _VI_FUNC hpe1432_setRange(ViSession vi, ViInt32 group, ViReal64 range);

Example
Sets the range of one or more channels.

Parameter      Description
-----
vi             Instrument Handle returned from hpe1432_init().
              Data Type: ViSession
              Input/Output: IN

group          This is the group handle returned from hpe1432_createChannelGroup()
              or a channel number of a channel that has been assigned to a group using
              hpe1432_createChannelGroup().

              Data Type: ViInt32
              Input/Output: IN
              Values:
              HPE1432_GROUP_ID_MIN      —8000
              HPE1432_GROUP_ID_MAX      12288

range         Sets the input range in volts.

              Data Type: ViReal64
              Input/Output: IN
              Values:
              HPE1432_RANGE_MIN         0.0
              HPE1432_RANGE_MAX         10.0

Comments:
hpe1432_set_range sets the range, of a single channel or group of channels, to the value given in range.
ID is either the ID of a group of channels that was obtained with a call to hpe1432_create_channel_group, or the ID of a
single channel.

range is the full scale range in volts. Signal inputs whose absolute value is larger than full scale will generate an ADC
overflow error. (Actually, there is several dB of overhead before the ADC will overflow, to avoid spurious overflow
indications.)

The actual range that is set will be the nearest legal range value that is greater than or equal to the value specified by the
range parameter.

For input channels, the range is used only when the input mode is Voltage or DEPE transducer power supply
(see hpe1432_set_input_mode). When the input mode is Charge, the range_charge parameter is used instead
(see hpe1432_set_range_charge). When the input mode is microphone mode, the range_mike parameter is used
instead (see hpe1432_set_range_mike).

For source channels the range specifies an overall maximum signal level (typically on a range DAC reserved for that
purpose), and can't be changed instantaneously during output. To change the signal amplitude during output, use
hpe1432_set_amp_scale, which can scale the output level by an (almost) arbitrary scale factor.

For tach channels, neither range nor amplitude are used.

This parameter may also be set with hpe1432_set_analog_input.

After a reset, input channels have the range set to 10 volts. Source channels have the range set to the minimum legal
source range (and the source is also inactive, so no signal is produced).

Return Value:
VI_SUCCESS: No error
Non VI_SUCCESS: Indicates error condition. To determine error message, pass the return value to routine
"hpe1432_error_message"
```

# VX|plug&play Library Function List

following function sequence from a MATLAB environment.

Figure 16 below shows another example of the results obtained from a 10 second run up (1000 to 3500 RPM) of an automobile engine tracking the vibration (acceleration) response as a function of rpm. In this combined 3-D plot and top down view, the vibration response is plotted as harmonics of crankshaft rotation versus RPM. This presentation gives a quick overall feel of the vibration signature as a function of rpm and orders for this engine with over 100,000 miles on its odometer.

To obtain these results a four page MATLAB program sets up and controls the HP E1432 16 Channel Digitizer. The HP E1432A digitizer in conjunction with its optional tachometer, digitizes the acceleration data at a fixed sample rate and then using the tachometer data and the sampled data (stored in its 32 MByte of RAM), resamples the

data via a built-in digital filter to provide new samples that are now sampled at even increments of crankshaft rotation. This process is repeated at every 100 rpm increase in engine speed (user specified) with the results sent to the host computer on-line. This particular set of plots was obtained during a 10 second engine run-up with these final graphical results appearing on PC's screen within 5 seconds of completing the run-up (using an HP E6233A embedded Pentium controller). Matlab's user interface building tools make the user interface shown to setup the hardware easy to build - taking less than an hour to create. This program is one of the example MATLAB scripts included with the E1432A/33A/34A Plug and Play library. These MATLAB examples along with additional examples in C, Visual Basic and HP VEE give you a great head start in developing your application solutions.

## Control by array

arrayControl  
arrayNextChan  
arrayReadChan

## Arm

getArmChannel  
setArmChannel  
getArmMode  
setArmMode  
getArmTimeInterval  
getArmTimeIntervalLimits  
setArmTimeInterval  
getNextArmRpm  
getPreArmMode  
setPreArmMode  
getPreArmRpm  
getPreArmRpmLimits  
setPreArmRpm  
getRpmHigh  
getRpmHighLimits  
setRpmHigh  
getRpmInterval  
getRpmIntervalLimits  
setRpmInterval  
getRpmLow  
getRpmLowLimits  
setRpmLow  
getRpmSmoothing  
getRpmSmoothingLimits  
setRpmSmoothing

## Control

setAutoGroupMeas  
getClockMaster  
setClockMaster  
getClockSource  
setClockSource  
getDataPort

**Figure 16:**  
Four cylinder automotive engine vibration response from a 10 second engine run up from 1000 to 3500 RPM using Plug&Play library example for MATLAB.

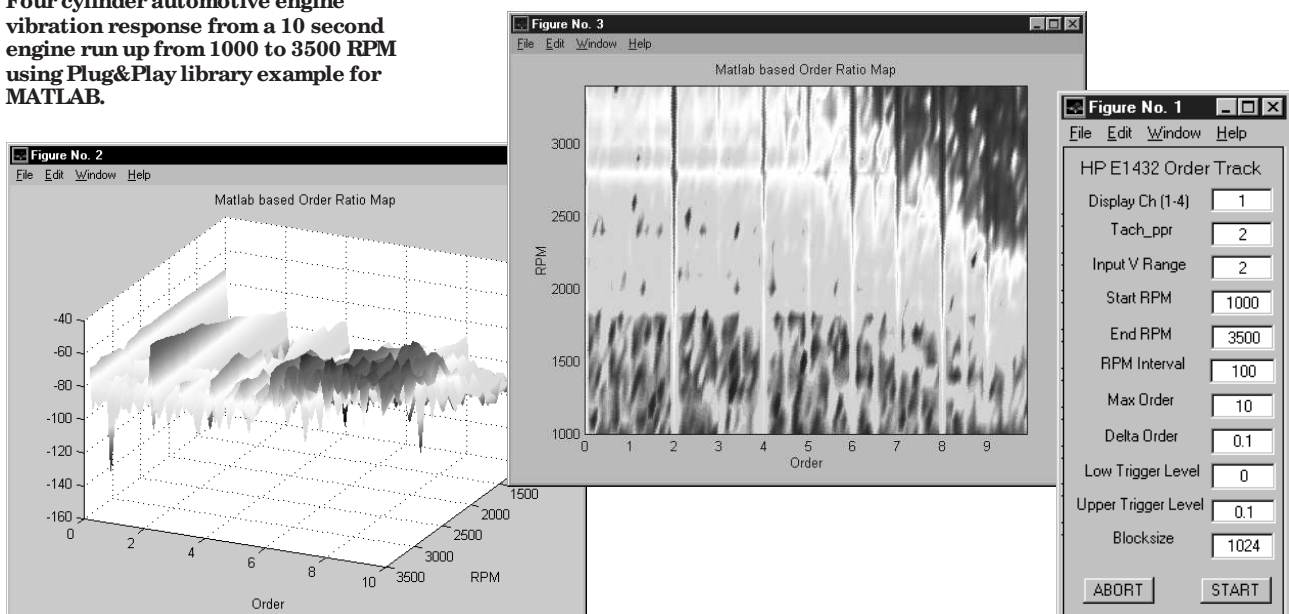

setDataPort  
 getFifoSize  
 setFifoSizeLimits  
 setFifoSize  
 getLbusMode  
 setLbusMode  
 getLbusReset  
 getMultiSync  
 setMultiSync  
 getSumbus  
 setSumbus  
 getTlTrgClock  
 setTlTrgClock  
 getTlTrgGclock  
 setTlTrgGclock  
 getTlTrgLines  
 setTlTrgLines  
 getTlTrgSatrg  
 setTlTrgTrigger  
 getTlTrgSatrg

---

**Data Transfer**

blockAvailable  
 checkOverloads  
 getCurrentValue  
 getRawTachs  
 readFloat64Data  
 readRawData  
 readTrailerData

---

**Format**

getAppendStatus  
 setAppendStatus  
 getDataMode  
 setDataMode  
 getDataSize  
 setDataSize

---

**High Access**

setAnalogInput  
 setDataFormat  
 setInterrupt  
 setTrigger

---

**Input**

autoRange  
 autoZero  
 getAcSettling  
 setAcSettling  
 getAmpScale  
 getAmpScaleLimits  
 setAmpScale  
 getAntiAliasAnalog  
 setAntiAliasAnalog  
 getAntiAliasDigital  
 setAntiAliasDigital  
 getAutoRangeMode  
 setAutoRangeMode  
 getCalDac  
 getCalDacLimits  
 setCalDac  
 getCalVoltage  
 getCalVoltageLimits

setCalVoltage  
 getCalin  
 setCalin  
 getClockFreq  
 getClockFreqLimits  
 setClockFreq  
 setCouplingFreq\*  
 getCoupling  
 getCouplingFreq\*  
 getCouplingFreqLimits\*  
 setCoupling  
 getInputLow  
 setInputLow  
 getInputHigh  
 setInputHigh  
 getInputMode  
 setInputMode  
 getInputOffset  
 getInputOffsetLimits  
 setInputOffset  
 getPeakDecayTime\*  
 getPeakDecayTimeLimits\*  
 setPeakDecayTime\*  
 getPeakMode  
 setPeakMode  
 getRange  
 getRangeLimits  
 setRange  
 getRangeCharge  
 getRangeChargeLimits  
 setRangeCharge  
 getRangeMik  
 getRangeMikLimits  
 setRangeMik  
 getRmsAvgTime\*  
 getRmsAvgTimeLimits\*  
 setRmsAvgTime\*  
 getRmsMode  
 setRmsMode  
 getScale  
 getWeighting\*  
 setWeighting\*

---

**Interrupt**

getInterruptMask  
 setInterruptMask  
 getInterruptPriority  
 getInterruptPriorityLimits  
 setInterruptPriority  
 getInterruptReason  
 reenableInterrupt

---

**Measurement**

getActive  
 setActive  
 getAvgMode  
 setAvgMode  
 getAvgNumber  
 getAvgNumberLimits  
 setAvgNumber  
 getAvgUpdate  
 getAvgUpdateLimits  
 setAvgUpdate  
 getAvgWeight  
 getAvgWeightLimits  
 setAvgWeight  
 getBlocksize  
 getBlocksizeCurrentMax

getBlocksizeLimits  
 setBlocksize  
 getCalcData  
 setCalcData  
 getCenterFreq\*\*  
 getCenterFreqLimits\*\*  
 setCenterFreq\*\*  
 getCurrentRpm  
 getDataRpm  
 getDecimationOutput  
 setDecimationOutput  
 getDecimationOversample  
 setDecimationOversample  
 getDecimation  
 getDeltaOrder  
 getDeltaOrderLimits  
 setDeltaOrder  
 getEnable  
 setEnable  
 getFilterFreq  
 getFilterFreqLimits  
 setFilterFreq  
 getFilterSettlingTime  
 getFilterSettlingTimeLimits  
 setFilterSettlingTime  
 getMaxOrder  
 getMaxOrderLimits  
 setMaxOrder  
 getMeasTimeLength  
 getMeasTimeLengthLimits  
 setMeasTimeLength  
 getMmfDelay  
 setMmfDelay  
 getOverlap  
 getOverlapLimits  
 setOverlap  
 getRmsDecayTime\*  
 getRmsDecayTimeLimits\*  
 setRmsDecayTime\*  
 getSampleMode  
 setSampleMode  
 getSamplesToPreArm  
 getSpan  
 getSpanLimits  
 setSpan  
 getWindow  
 setWindow  
 getXferSize  
 getXferSizeLimits  
 setXferSize  
 getZoom\*\*  
 setZoom\*\*

---

**Measurement Action**

armMeasure  
 cachedParmUpdate  
 finishMeasure  
 getMeasState  
 initMeasure  
 initMeasureFinish  
 initMeasureToBooted  
 preArmMeasure  
 resetMeasure  
 triggerMeasure

\* Function only available in HP E1433A.

\*\* Function only available in HP E1432A.

---

**Source**

checkSrcArbRdy  
checkSrcOverload  
checkSrcOverread  
checkSrcShutdown  
getDutyCycle  
getDutyCycleLimits  
setDutyCycle  
getRamp  
getRampRate  
getRampRateLimits  
setRamp  
setRampRate  
getSineFreq  
getSineFreqLimits  
setSineFreq  
getSinePhase  
getSinePhaseLimits  
setSinePhase  
getSourceBlocksize  
getSourceBlocksizeLimits  
setSourceBlocksize  
getSourceCenterFreq  
getSourceCenterFreqLimits  
setSourceCenterFreq  
getSourceCola  
setSourceCola  
getSourceMode  
setSourceMode  
getSourceOutput  
setSourceOutput  
getSourceSeed  
getSourceSeedLimits  
setSourceSeed  
getSourceSpan  
getSourceSpanLimits  
setSourceSpan  
getSourceSum  
setSourceSum  
getSrcArbStates  
getSrcBufferInit  
setSrcBufferInit  
getSrcBufferMode  
setSrcBufferMode  
getSrcBufferSize  
getSrcBufferSizeLimits  
setSrcBufferSize  
getSrcParmMode  
setSrcParmMode  
srcGetFw rev  
scrProgRomImage  
srcRxf  
srcsrcGetRev  
updateSrcParm  
writeSrcBufferData

---

**Tach**

getTachClockFreq  
getTachDecimate  
getTachDecimateLimits  
setTachDecimate  
getTachDelay  
getTachHoldoff  
getTachHoldoffLimits  
setTachHoldoff  
getTachMaxTime  
getTachMaxTimeLimits

setTachMaxTime  
getTachPpr  
getTachPprLimits  
setTachPpr  
sendTachs

---

**Trigger**

getAutoTrigger  
setAutoTrigger  
getCalTrigCorr  
getTriggerChannel  
setTriggerChannel  
getTriggerDelay  
getTriggerDelayLimits  
setTriggerDelay  
getTriggerExt  
setTriggerExt  
getTriggerLevel  
getTriggerLevelLimits  
setTriggerLevel  
getTriggerMaster  
setTriggerMaster  
getTriggerMode  
setTriggerMode  
setTriggerSlope  
getTriggerSlope  
getTriggersPerArm  
getTriggersPerArmLimits  
setTriggersPerArm  
sendTrigger

---

**Utility****Errors**

errorDetails  
error\_message  
error\_query

**Low Level**

readRegister16  
readRegister32  
scaDspDownload  
scaDspExecQuery  
readI2C  
writeRegister16  
writeRegister32  
writeI2C

**Overhead**

channelGroupAdd  
channelGroupRemove  
createChannelGroup  
deleteAllChanGroups  
deleteChannelGroup  
find  
getAutoGroupMeas  
getGroupInfo  
getHWConfig  
getMeasWarningString  
getMeasWarning  
getNumChans  
install  
preset  
reset  
resetLbus  
revision\_query  
selftest

**For more information about Hewlett-Packard test & measurement products, applications, services, and for a current sales office listing, visit our web site, <http://www.hp.com/go/tmdir>. You can also contact one of the following centers and ask for a test and measurement sales representative.**

**United States:**

Hewlett-Packard Company  
Test and Measurement Call Center  
P.O. Box 4026  
Englewood, CO 80155-4026  
1 800 452 4844

**Canada:**

Hewlett-Packard Canada Ltd.  
5150 Spectrum Way  
Mississauga, Ontario  
L4W 5G1  
(905) 206 4725

**Europe:**

Hewlett-Packard  
European Marketing Centre  
P.O. Box 999  
1180 AZ Amstelveen  
The Netherlands  
(31 20) 547 9900

**Japan:**

Hewlett-Packard Japan Ltd.  
Measurement Assistance Center  
9-1, Takakura-Cho, Hachioji-Shi,  
Tokyo 192, Japan  
Tel: (81) 426 56 7832  
Fax: (81) 426 56 7840

**Latin America:**

Hewlett-Packard  
Latin American Region Headquarters  
5200 Blue Lagoon Drive  
9th Floor  
Miami, Florida 33126  
U.S.A.  
Tel: (305) 267-4245  
(305) 267-4220  
Fax: (305) 267-4288

**Australia/New Zealand:**

Hewlett-Packard Australia Ltd.  
31-41 Joseph Street  
Blackburn, Victoria 3130  
Australia  
Tel: 1 800 629 485 (Australia)  
0800 738 378 (New Zealand)  
Fax: (61 3) 9210 5489

**Asia Pacific:**

Hewlett-Packard Asia Pacific Ltd.  
17-21/F Shell Tower, Times Square,  
1 Matheson Street, Causeway Bay,  
Hong Kong  
Tel: (852) 2599 7777  
Fax: (852) 2506 9285

**Data subject to change.**

**Copyright © 1997 Hewlett-Packard Co.  
Printed in U.S.A. 12/97  
5966-3062E**