HP 3565S

Measurement Hardware

Technical Specifications

Modular hardware for precision measurements

The HP 3565S measurement hardware combined with application software and a host computer forms a high performance multi-channel measurement system. The hardware acquires signals in both time and frequency domains and is easily configured for large multiple input, multiple output measurements.

System characteristics include:

- Signal acquisition and processing up to 102.4 kHz
- Host-independent—interfaces to any computer that supports the IEEE-488 interface.
- Up to 496 input channels
- 102.4 kHz realtime bandwidth
- Display updates of 64 spectra/sec
- Throughput to disk rate of 2.6 Mbytes/sec via SCSI interface
- Buffered analog output for tape recorders
- Built-in preamps for piezo-electric and integrated electronics piezo electric transducers

System performance depends on the application software used to control the hardware. Specifications in this data sheet denote guaranteed performance of the hardware when controlled by appropriate software.

System description

The HP 3565S measurement hardware includes either a single, 4-slot, HP 35650B mainframe or from 1 to 8 interconnected HP 35650A mainframes. Each HP 35650A mainframe contains 8 module slots for a possible system total of 64 slots. Nine different of modules can used to build a system:

- Signal processing module
- 51.2 kHz input module
- 102.4 kHz input module
- 4-channel 12.8 kHz input module
- 8-channel 12.8 kHz input module
- 102.4 kHz source module
- Programmable DAC module
- Tachometer/Trigger module
- SCSI throughput module

Each system must contain one signal processing module. The remaining slots may contain a combination of the other modules. Module configuration requirements depend on application software.

NOTE: Internal calibration of the hardware requires either a 102.4 kHz source module or a programmable DAC module.

NOTE: HP 35635R software supports multiple synchronized systems controlled by one host computer. (The HP 35635R Programmer Toolkit software is described on page 23.)

A high-speed system bus provides communication between mainframes and modules. Data transfer between the host computer and the signal processing module takes place via an HP-IB (IEEE-488) interface.

HP 35650A/B Mainframe Systems

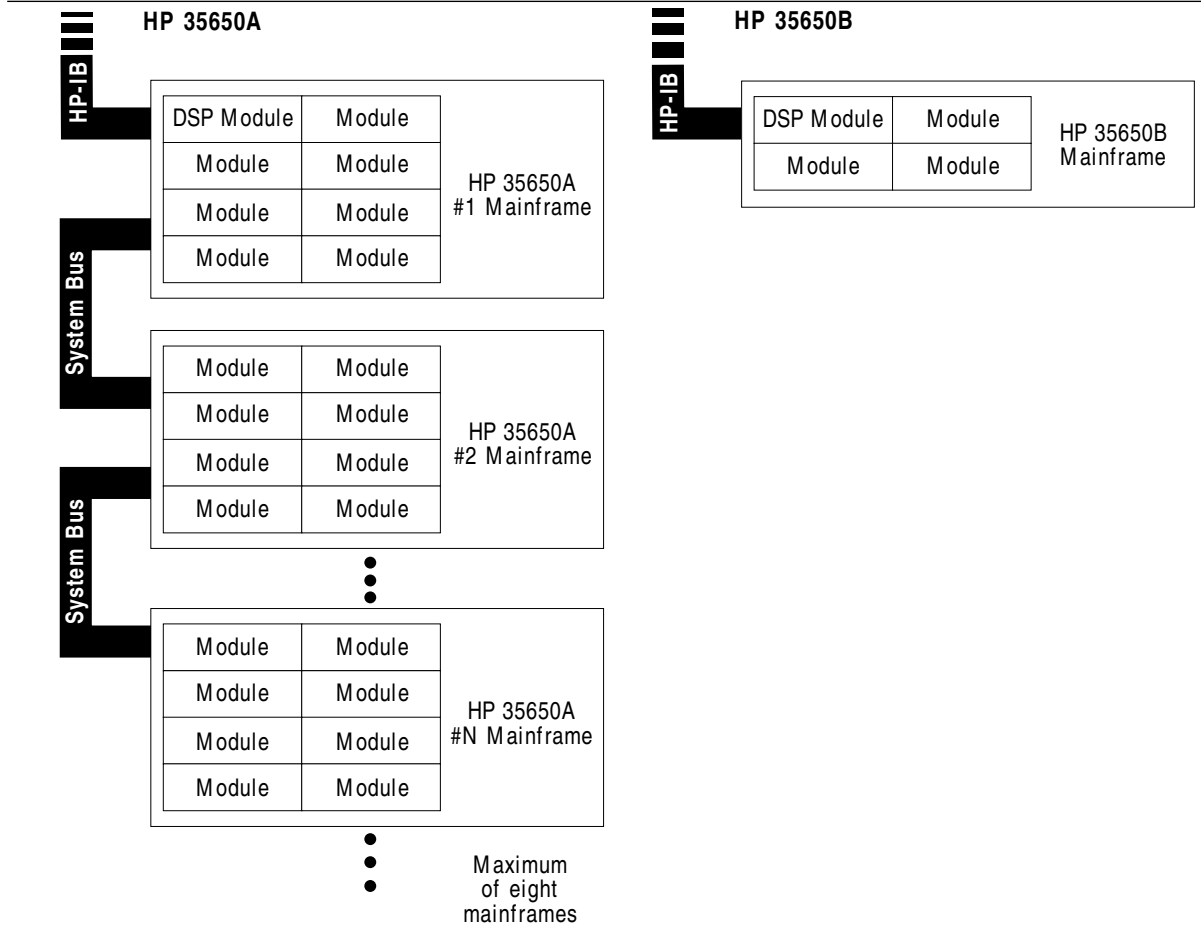
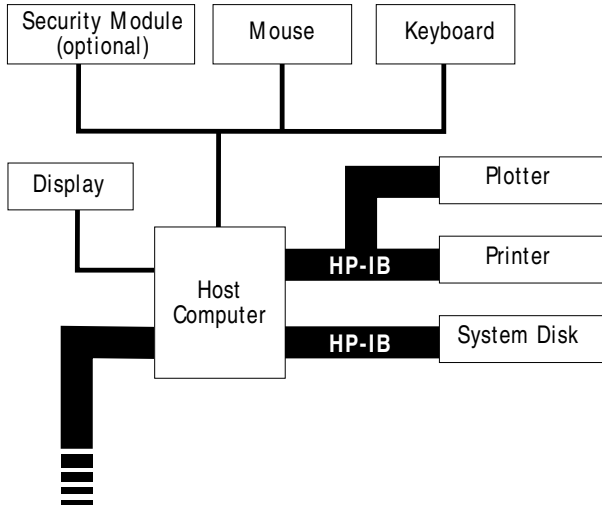

HP 35650A and 35650B Mainframes

The HP 35650A and 35650B mainframes house the HP 3565S modules and provide the following features:

	HP35650A	HP35650B
Module slots	8	4
Module power	yes	yes
Forced air available	yes	yes
Calibration bus	yes	yes
Internal sample clock	yes	yes
Trigger signal	yes	yes
System bus available for interconnecting mainframes	yes	no*
400-Hz line power compatible	no	yes
Two minute fan cut-off for quiet operation	no	yes
Split backplane allows 2 signal processor modules	no	yes**

* A HP 35650B mainframe can not be interconnected with other mainframes. It is strictly limited to operating in single mainframe systems.

** A HP 35650B can hold two signal processor modules acting as independent systems. Order HP 35650B-H01. This configuration requires user-generated control code.

Select the HP 35650B mainframe when your application requires 4 modules or less. A signal processor module, a source, and 2 eight-channel, 12.8 KHz modules is a typical 4-slot configuration. Its size and weight also make it a good solution for applications requiring transportability.

Battery power is available via the HP 85901A portable AC power source.

Select the HP 35650A mainframe when your application requires more than 4 modules, or to expand the system later.

The HP 35650A mainframe can be used on the bench or installed in either the HP E3660A rack (for up to two mainframes) or the HP E3661A rack (for up to four mainframes). A "top extractor fan" and appropriate power distribution units must be ordered. See table on this page.

The HP 35650B mainframe can also be used on a bench or installed in any HP 46298 series rack.

The HP 46298 series rack is recommended to house rack-mountable breakout boxes for the HP 35655A input modules. An HP 46298C 1600 mm rack can hold up to 16-rack panels (equivalent to 256 channels).

Specifications

Weight	
HP 35650A:	15.3 Kg (33.7 lb)
HP 35650B:	10.9 Kg (24.0 lb)
HP 35651C:	1.6 Kg (3.5 lb)
HP 35652A:	2.0 Kg (4.4 lb)
HP 35652B:	2.0 Kg (4.4 lb)
HP 35653C:	1.6 Kg (3.5 lb)
HP 35654B:	1.6 Kg (3.5 lb)
HP 35655A:	2.0 Kg (4.4 lb)
HP 35655B:	2.0 Kg (4.4 lb)
HP 35656B:	2.0 Kg (4.4 lb)
HP 35658A:	1.5 Kg (3.2 lb)
HP 35659A:	2.4 Kg (5.2 lb) incl. opt. AT3

System Rack Cabinets

HP E3660A (2 Mainframes)

North American

120V order option AW3 PDU
order HP E4470A extractor fan
240V order HP E4472A installation kit
order HP E4452A PDU

International

240V order option AW5 PDU
order HP E4471A extractor fan

HP E3661A (4 Mainframes)

North American

120V order option AW3 PDU
order HP E4455A, second PDU
order HP E4470A extractor fan
240V order HP E4472A PDU installation kit
order HP E4456A PDU (up to 4 mainframes)
order HP E4471A extractor fan

International

240V order option AW5 PDU
order HP E4471A extractor fan

Using Application Software with the HP 3565S

Application software may interact with the HP 3565S hardware in a variety of ways. One method is to access the measurement hardware through an established user interface such as the HP 3566A and 3567A PC-based Spectrum/Network Analyzer software. Another method is to work with command libraries available through the HP 35635R Programmers Toolkit. This method increases measurement speed and allows highly customized measurements. It also requires significant programming effort on the part of the user.

The table below shows compatibility between HP 3565S hardware and various application software products. For information on hardware compatibility with application software available from third party vendors contact your Hewlett-Packard sales representative.

Third Party Support of HP 3565S Hardware

Various independent third party software vendors support the HP 3565S hardware set in their applications. Each of these vendors support a different set of HP 3565S modules to solve specific user problems and needs. Applications supporting HP 3565S hardware are currently provided by Leuven Measurement Systems (LMS), Mahrenholtz and Partner M&P), Structural Measurements Systems (SMS), Creare Inc., Structural Dynamics Research Corporation (SDRC), and other local third parties. Specific HP 3565S hardware support questions should be addressed directly to each third party. Your HP sales representative can give you more information on these packages and how to contact each vendor.

HP 3565S Modules	HP VISTA* HP 35630A	HP VISTA* HP 35630B	HP Prog. Toolkit HP 35635R	HP 3566/67A PC System
HP 35651A	X			
HP 35651B/C		X	X	X
HP 35652A	X	X	X	X
HP 35652B		X**	X	X
HP 35653C	X	X	X	X
HP 35654A/B		X	X	X
HP 35655A		X	X	X
HP 35655B			X	
HP 35656B			X	X
HP 35658A			X	X
HP 35659A			X	X

*Software no longer available for sale

** up to 51.2 kHz only

HP 35650A Mainframe

Internal Sample Clock Generator

Frequency: 262,144 Hz

Accuracy: ±8 ppm

External Sampling Rate

Maximum: 280 kHz

Signal type: TTL

Power Supply

Line Voltage:

115 Vac range: 90 to 127 Vac

230 Vac range: 195 to 253 Vac

Line Frequency: 47.5 to 66 Hz
(either range)

Line Current:

115 Vac range: < 6.0 amps

230 Vac range: < 3.0 amps

Line Power: 600 VA max

Option 715: 15 inch fast bus cable

Option 788: 88 inch, fast bus cable

Rack mount brackets: HP part number 5062-3979

NOTE: Two BNC cables and a system bus cable are required to link two or more HP 35650A mainframes. The system bus cable allows all mainframes and modules to access common commands and data.

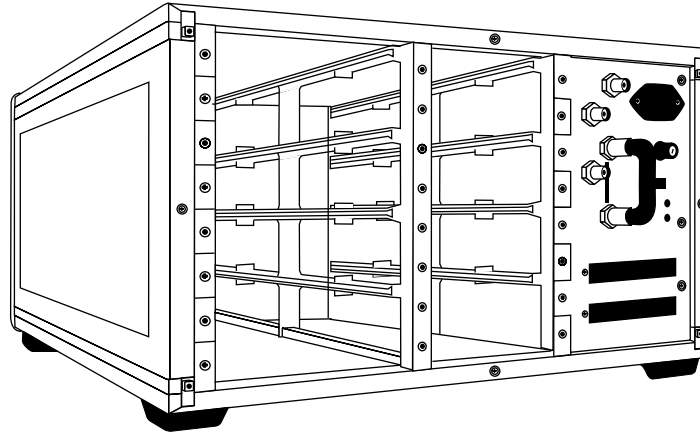

Mainframe Dimensions

222 mm (8.75 in) high

432 mm (17.0 in) wide

584 mm (23.0 in) deep

Altitude: up to 4572 meters
(15,000 feet)

* Environmental specifications for the mainframe apply to the modules.

Environmental*

Ambient Temp: 0 to 55°C

Relative Humidity: Can be operated in environments with relative humidity of 95% at 40°C. Modules should be protected from rapid temperature changes, which may cause condensation.

HP 35650A Mainframe

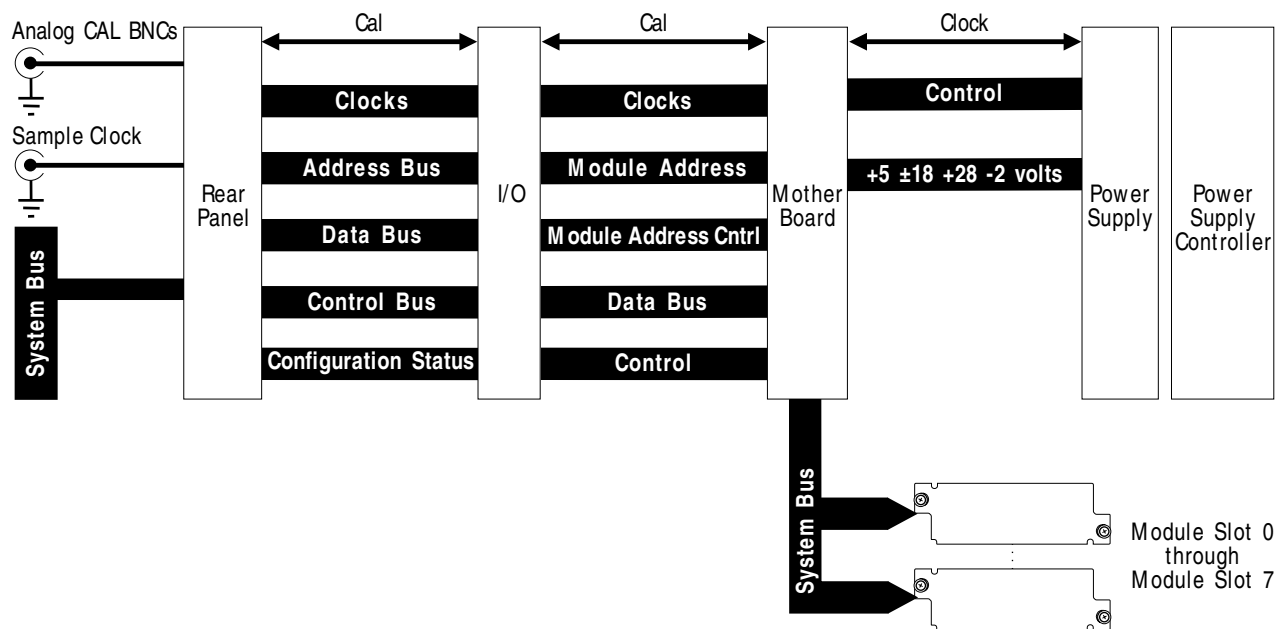

HP 35650B Mainframe

Internal Sample Clock Generator

Frequency: 262,144 Hz
 Accuracy: ±8 ppm

External Sampling Rate

Maximum: 280 kHz
 Signal type: TTL

Power Supply

Line Voltage:
 115 Vac range: 90 to 127 Vac
 230 Vac range: 195 to 253 Vac

Line Frequency:
 115 Vac range: 47.5 to 440 Hz
 230 Vac range: 47.5 to 66 Hz

Line Current:
 115 Vac range: < 3.0 amps
 230 Vac range: < 2.0 amps

Line Power: 250 VA max

NOTE: Battery power available via the HP 85901A Portable AC Power Source.

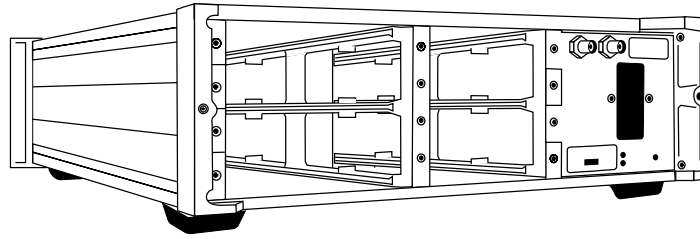

Mainframe Dimensions

133 mm (5.25 in) high
 432 mm (17.0 in) wide
 622 mm (24.5 in) deep

Altitude: up to 4572 meters (15,000 feet)

Environmental*

Ambient Temp: 0 to 55°C

Relative Humidity: Can be operated in environments with relative humidity of 95% at 40°C. Modules should be protected from rapid temperature changes, which may cause condensation.

* Environmental specifications for the mainframe apply to the modules.

HP 35650B Mainframe

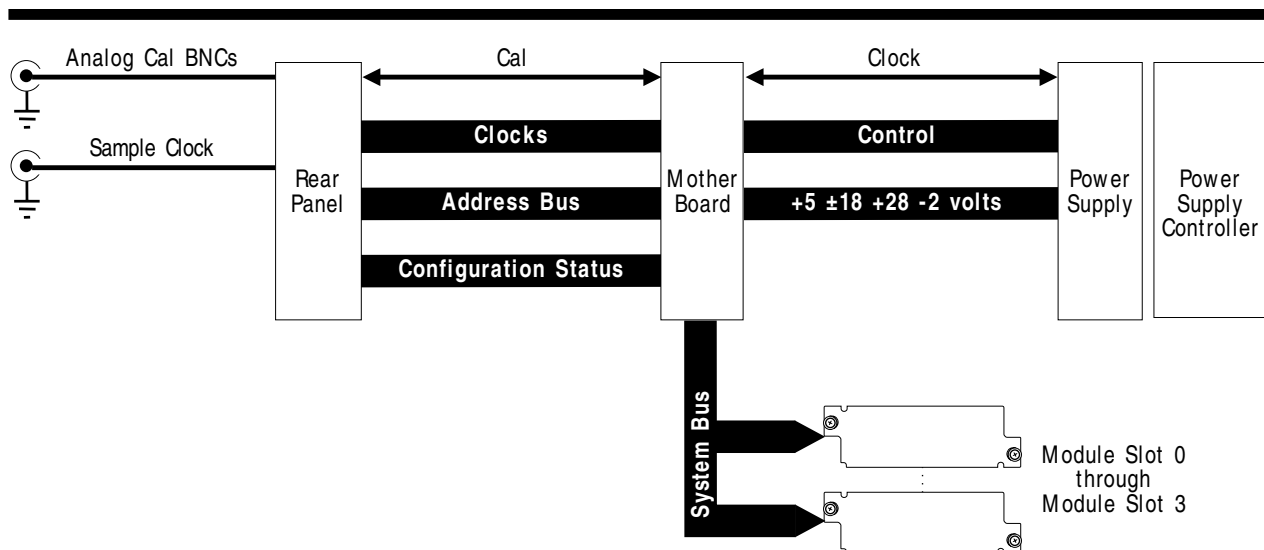

HP 35651C/35654B Signal Processing Modules

The signal processing module performs the following functions for the HP 3565S system:

- Control of all system operations, including data flow between modules
- Transfer of measurement data to host computer via HP-IB
- Direct control of data through-put to disk
- Execution of downloadable programs from application software
- Synchronization of multiple systems and simultaneous triggering of multiple systems with external SMB connectors.
- System hardware diagnostics using the RS-232 port.

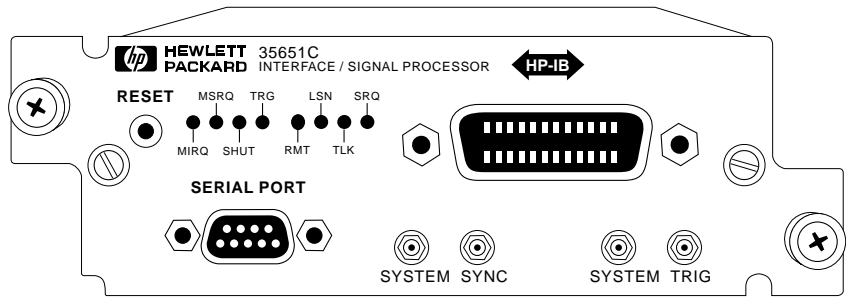

While the HP 35651C and HP 35654B perform identical functions, there are two major differences between the modules.

The HP 35651C has one Motorola 56002 digital signal processing (DSP) chip and 1 Mbyte of RAM (4 or 16 Mbytes of RAM are available by ordering option 104 or 116). The HP 35654B has two

Motorola 56002 DSP chips and 4 Mbytes of memory (16 Mbytes are available by ordering option 116). The additional DSP chip gives the HP 35654B the capability of greater signal processing speed. This added capability is only accessible through application software that accesses the extra DSP chip.

HP 35651C Signal Processing Module

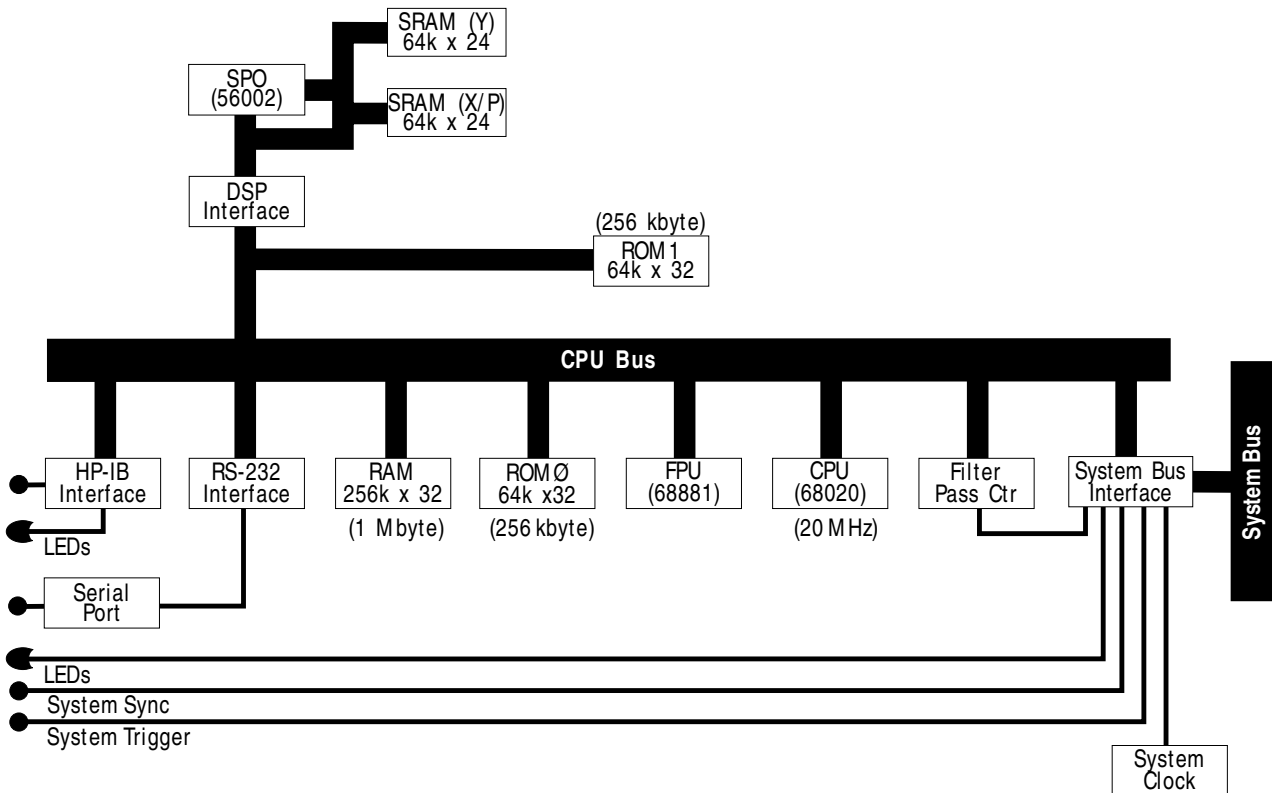

Features

	HP 35651C	HP 35654B
DSP chip*	DSP56002 (one)	DSP56002 (two)
Processor	MC68020 (20 MHz)	MC68020 (20 MHz)
Floating Point Coprocessor	MC68881 MC68882 (w/opt 104 or 116)	MC68882
DSP RAM Wait states	0	0
FFT time (nominal)**	4.0 ms	3.5 ms
Realtime Bandwidth	51.2 kHz	102.4 kHz
Main Memory	1 Mbyte (standard) 4 Mbyte w/opt 104 16 Mbyte w/opt 116	4 Mbytes (standard) 16 Mbyte w/opt 116

* The DSP chip, the processor and the coprocessor are all Motorola products.

** The FFT time is calculated using a 1K complex block size (800 lines of alias-free resolution, includes windowing, and bit reverse).

Transfer Rates

Module to module system bus maximum:	2.5 Msamples/sec
Signal processing module to host :	329 kbytes/sec
Module to signal processing module memory:	1.7 Msamples/sec
Maximum throughput rate:	>1.3 Msamples/sec using HP 35659A with option AT3

HP-IB Implementation SH1 AH1 T6 TE0 L4 LE0 SR1 RL0 PP0 DC1 DT1 C4,11
(IEEE Std 488-1978)

HP 35654B Signal Processing Module

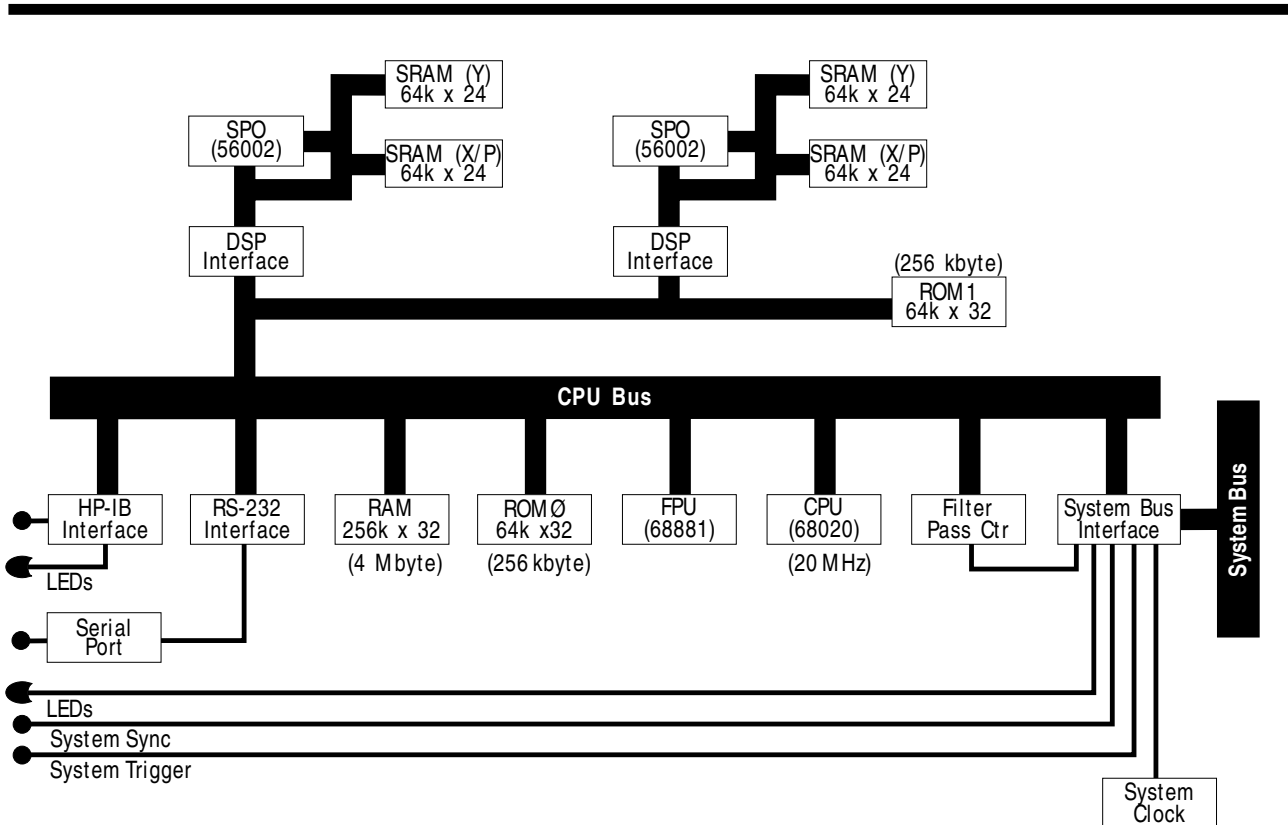

HP 35652A/B Input Modules

The HP 35652A is a single-channel analog input module for measurements from dc to 51.2 kHz. The HP 35652B is the same module with an extended frequency range up to 102.4 kHz. Aside from maximum frequency span, the two modules have the same features.

The HP 3565S measurement hardware can acquire data from the HP 35652A/B input modules at an internal sample rate of 262,144 Hz per channel. Additional features include:

- Three input modes: voltage, charge and IEPE 4 mA constant-current
- Anti-alias protection on all spans
- Auto-ranging
- Digital zoom capability on all spans and all ranges
- 80 dB dynamic range*
- Input data may be transferred directly to HP 35659A SCSI interface with optional AT3 disk drive.
- Full scale voltage ranges from 1.26 mVpk to 39.8 Vpk in 2 dB steps
- Full scale charge ranges from 0.126 pC to 3980 pC in 2 dB steps

* The HP 35652B has 80 dB of dynamic range at frequencies below 50 kHz. From 50 kHz to 100 kHz dynamic range is 75 dB.

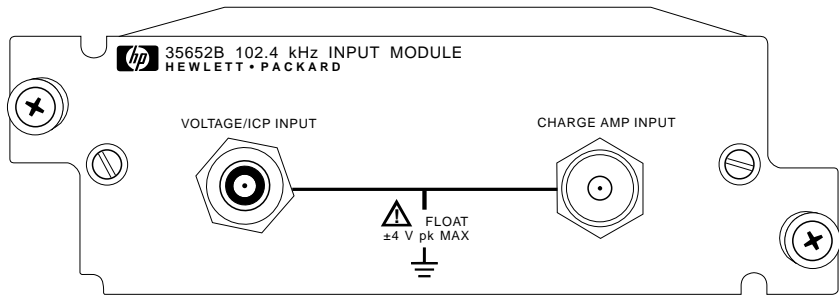

Input Module Block Size

Lines of Resolution*	Complex Block Size	Real Block Size
400	512	1024
800	1024	2048
1600	2048	4096
3200	4096	8192

* Maximum resolution for specified dynamic range.

The HP 35652A/B modules also come with an option for a buffered analog output. Option 001 provides a 2 volts peak (full scale) analog output. This option is particularly useful for analog tape recording of data for archive and backup purposes.

Frequency Spans

Spans	Input Module			
	HP 35652A	HP 35652B	HP 35655A (see page 15)	HP35655B (see page 15)
102.4 kHz		X		
51.2 kHz	X	X		
25.6 kHz	X	X		
12.8 kHz	X	X	X	X
6.4 kHz	X	X	X	X
3.2 kHz	X	X	X	X
1.6 kHz	X	X	X	X
800 Hz	X	X	X	X
400 Hz	X	X	X	X
200 Hz	X	X	X	X
100 Hz	X	X	X	X
50 Hz	X	X	X	X
25 Hz	X	X	X	X
12.5 Hz	X	X	X	X
6.25 Hz	X	X	X	X
3.125 Hz	X	X	X	X
1.562 Hz	X	X	X	X
781 mHz	X	X	X	X
390 mHz	X	X	X	X
195 mHz	X	X	X	X

Center Frequency Resolution: 0.25 Hz

HP 35652A/B/ Input Modules

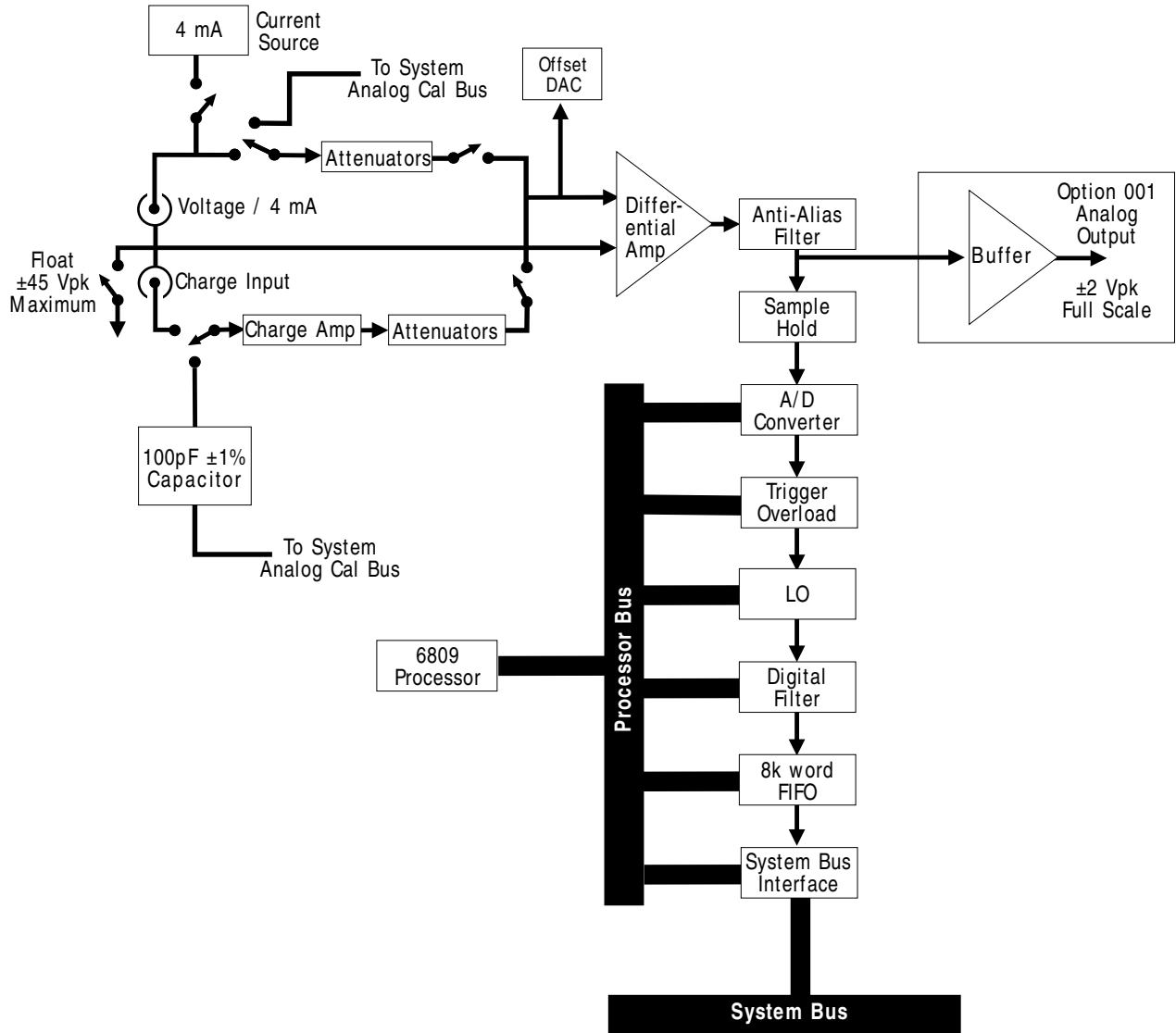

HP 35652A/B

Specifications

Frequency Range

HP 35652A: dc to 51.2 kHz
 HP 35652B: dc to 102.4 kHz

NOTE: Specifications do not apply if anti-aliasing filter is bypassed. Unless otherwise noted, specifications do not apply when test signal is applied to the low side of inputs. Specifications do not apply if cables are physically connected to both voltage and charge inputs simultaneously.

Voltage Input Accuracy

Single-Channel Amplitude:

Calibrated with the HP 35653C source cal signal and calibration routine available with HP 35630B and 35635R software.

Frequency	Input Ranges	Accuracy
All frequencies	1.26 mVpk to 3.16 mVpk	± 0.25 dB
	3.98 mVpk to 39.8 Vpk	± 0.15 dB

Uncalibrated; after correction for digital filters characteristics

Frequency	Input Ranges	Accuracy
0.1 Hz to 20 kHz	1.26 mVpk to 3.16 mVpk	± 0.5 dB
	3.98 mVpk to 39.8 Vpk	± 0.3 dB
20 kHz to 50 kHz	1.26 mVpk to 3.16 mVpk	± 0.75 dB
	3.98 mVpk to 39.8 Vpk	± 0.65 dB

HP 35652B:		
50 kHz to 100 kHz	All Ranges	± 0.8 dB

Channel-to-Channel Amplitude and Phase:

Calibrated with the HP 35653C source cal signal and calibration routine available with HP 35630B and HP 35635R software

Frequency	Input Ranges	Accuracy
0.1 Hz to 50 kHz	1.26 mVpk to 39.8 Vpk	± 0.1 dB

Frequency	Input Ranges	Accuracy
0.1 Hz to 50 kHz	All Ranges	± 0.5 degrees

Uncalibrated; after correction for digital filters characteristics

HP 35652A/B:		
Frequency	Input Ranges	Accuracy
0.1 Hz to 20 kHz	1.26 mVpk to 3.16 mVpk	± 1.0 dB
	3.98 mVpk to 39.8 Vpk	± 0.6 dB
20 kHz to 50 kHz	1.26 mVpk to 3.16 mVpk	± 1.50 dB
	3.98 mVpk to 39.8 Vpk	± 1.26 dB
50 kHz to 100 kHz	All ranges	± 1.6 dB

Frequency	Input Ranges	Accuracy
0 Hz to 12.5 kHz	All Ranges	± 7.5 degrees
12.5 kHz to 25 kHz		± 15.0 degrees
25 kHz to 50 kHz		± 30 degrees

Full Scale Ranges: 1.26 mVpk

(Rs=0Ω, isolated mode)

Ranges	0 to 66 Hz	66 Hz to 1 kHz
1.26 mVpk to 398 mVpk (dc coupling)	>80 dB	>70 dB
1.26 mVpk to 398 mVpk (ac coupling)	>70 dB	>60 dB
501 mVpk to 3.98 Vpk	>60 dB	>50 dB
5.01 Vpk to 39.8 Vpk	>40 dB	>30 dB

(-58 dBVp) to 39.8 Vpk
(+32 dBVp) in 2 dB steps

Input Impedance:

High-to-low: 1MΩ ±5% (input capacitance < 150 pF)

Low-to-case single ended:
(ground) 55Ω ±15Ω

Low-to-case isolated: (float)
1 MΩ nominal (input capacitance < 10,000 pF)

Input Coupling: 3 dB ac roll off
< 1 Hz

Input Module Autozero modes:
(HP 35652A/B and HP 35655A/B)

ZERO	compensates for offsets with the input hardware.
OFS	adjusts the input so that fixed offset voltage at the input produces a measurement with a zero dc input.
INP	measures the dc value of the input at the time of the autozero and attempts to adjust the front-end to reduce that dc value to zero.
BUCKOUT (HP 35655A/B ONLY)	Applies an independent dc offset voltage of up to ±10 V to the BNC shell. Intended for use with 2.4 mA constant-current input mode.

Common Mode Rejection Ratio:

NOTE: In Buckout mode, the user is causing the module to “buckout” the dc offset of the signal going into the HP 35655A/B. This is done by putting a voltage on the “minus” (BNC shell) input, so that the dc offset on the “plus” input is near zero. The “plus” input is then measured. The “minus” input is kept at a low impedance, much like the grounded input mode, so that common mode signals will not introduce inaccuracies into the measurement.

Noise: (Rs=50 ohm, 16 averages)

20 to 200 Hz: (frequency dependent)	$< (565/\sqrt{f}) \text{ nVrms}/\sqrt{\text{Hz}}$
Above 200 Hz: (frequency independent, measured on most sensitive range)	$< 40 \text{ nVrms}/\sqrt{\text{Hz}}$

Charge Input Accuracy

Channel-to-Channel Amplitude and Phase:

Calibrated with HP 35653C source cal signal and calibration routine available with HP 35630B and HP 35635R software

Frequency	Input Range*	Accuracy
At 1 kHz	All Ranges	± 0.3 dB
At flatness to 50 kHz	All Ranges	± 0.1 dB

Frequency	Input Range	Accuracy
0 Hz to 50 kHz	All Ranges	± 0.5 degrees

Uncalibrated; after correction for digital filters characteristics

HP 35652A/B:

Frequency	Input Range	Accuracy
10 Hz to 20 kHz	-18 to -10 dBpCp	± 1.2 dB
	-8 to +72 dBpCp	± 0.8 dB
20 kHz to 50 kHz	-18 to -10 dBpCp	± 1.7 dB
	-8 to +72 dBpCp	± 1.5 dB

HP 35652B:

50 kHz to 100 kHz	All Ranges	± 1.8 dB
-------------------	------------	----------

Frequency	Input Range	Accuracy
0 Hz to 12.5 kHz	All Ranges	± 7.5 degrees
12.5 kHz to 25 kHz		± 15.0 degrees
25 kHz to 50 kHz		± 30.0 degrees

* 0 dBpCp = 1pC (peak)

NOTE: These charge input specifications apply only to capacitive input devices with maximum capacitance of 30,000 pF and minimum shunt resistance of 10 MΩ.

Full Scale Charge Ranges:
0.126 pCpk (-18 dBpCp) to
3980 pCpk (+72 dBpCp) in
2 fB steps

Single-Channel Accuracy: (with full scale signals)

Calibrated with HP 35653C source cal signal and calibration routine available with HP 35630B and HP 35635R software

HP 35652B:
50 kHz to 100 kHz All Ranges ± 0.8 dB

Frequency	Input Ranges	Accuracy
At 1 kHz	-18 to -10 dBpCp	± 0.35 dB
	-8 to +72 dBpCp	± 0.25 dB
Flatness to 20 kHz	-18 to +72 dBpCp	± 0.10 dB
Flatness to 50 kHz	-18 to +72 dBpCp	± 0.15 dB

Uncalibrated; after correction for digital filters characteristics

HP 35652A/B:

Frequency	Input Ranges	Accuracy
10 Hz to 20 kHz	-18 to -10 dBpCp	± 0.6 dB
	-8 to +72 dBpCp	± 0.4 dB
20 kHz to 50 kHz	-18 to -10 dBpCp	± 0.85 dB
	-8 to +72 dBpCp	± 0.75 dB

HP 35652B:

50 kHz to 100 kHz	All ranges	± 0.9 dB
-------------------	------------	----------

Full Scale Ranges: 0.156 pC peak to
3981 pC peak

Input Impedance:

Low-to-Case: (single-ended mode)
55Ω nominal

Low-to-Case: (isolated mode) 1 MΩ
nominal (input capacitance
<10,000pF)

Low Frequency Rolloff: 3 dB ac
rolloff <1.5 Hz

Common Mode Voltage Sensitivity: (Cs=1000 pF, isolated mode)

Frequency	Input Ranges	Sensitivity
0 to 40 Hz	-18 to +32 dBpCp	<0.1 pC/V
	+34 to +52 dBpCp	<1.0 pC/V
	+54 to +72 dBpCp	<10 pC/V
40 to 66 Hz	-18 to +32 dBpCp	<0.01 pC/V
	+34 to +52 dBpCp	<0.1 pC/V
	+54 to +72 dBpCp	<1.0 pC/V
66 Hz to 1 kHz	-18 to +32 dBpCp	<0.03 pC/V
	+34 to +52 dBpCp	<0.3 pC/V
	+54 to +72 dBpCp	<3.0 pC/V

Noise: (Cs=1000 pF, 16 averages)

20 to 200 Hz: $< (620 \times 10^{-6} \sqrt{f})$ pCrms/ $\sqrt{(\text{Hz})}$
(frequency dependent)

Above 200 Hz: $< 45 \times 10^{-6}$ pCrms/ $\sqrt{(\text{Hz})}$
(frequency independent)

Voltage or Charge Inputs

Common Mode Range: -4.0 to 4.0 Vpk (isolated mode)

Dynamic Range:
(Rs = 50Ω, Cs=1000 pF,
16 averages, relative to full scale,
charge amp range ≥ 0)

Internal sample clock:
80 dB 0-51.2 kHz
(HP 35652A/B)
75 dB 51.2 to 102.4 kHz
(HP 35652B)

External sample clock:
65 dB all spans

Transducer Power Supply

Current:
4 mA nominal
Voltage:
26V nominal (open circuit)

Triggering

Modes: Freerun, input
Trigger signal level range:
±125% of full scale range
Resolution: ±0.031% of
full scale range

Ranging

Range modes:
fixed, single autorange

Option 001: Analog Output

Load Impedance: >4 kΩ, <600 pF

Output Connector: BNC female

Output Level (full-scale input
to voltage or charge inputs,
1 kHz, independent of range):
2 Vpk ±0.12V (+6 dBVp
±0.5 dB)

Output Amplitude Flatness
(uncalibrated, relative to 1 kHz):
<±0.7 dB, 10 Hz to 50 kHz

Output Impedance: <80Ω

Output Polarity (ref. to
HP 35652A voltage input):
Noninverting

Output Dynamic Range
(Rs = 50Ω, Cs = 100 pF, 16
averages, internal sampling):
20 Hz to 50 kHz = 70 dB
relative to full scale

With the charge amplifier set to a
range below 0 dBpCp, the follow-
ing specification applies:
20 Hz to 50 kHz = -70 dBpCp

Output DC Offset (ref. to 0 Vdc
at HP 35652A/B voltage input)

Input Ranges	Nominal
3.98 mVpk to 39.8Vpk	±500 mV

Abbreviations

dBVp - dB relative to 1 volt peak

dBpCp - dB relative to 1 pico-
coulomb peak

nVrms/√Hz - nano-volts
rms per square root hertz

pCrms/√Hz - pico-coulombs
rms per square root hertz

Rs - resistance of source or
termination connected to an input

Cs - capacitance of source or
termination connected to
charge amplifier

f - bin frequency in hertz

HP 35655A 8-Channel Input Module

HP 35655B 4-Channel Input Module

The HP 35655A provides eight separate analog input channels in one plug-in module. The HP 35655B provides four separate analog input channels in one plug-in module. Aside from the channel count, the two modules have the same specifications. Each input channel is sampled simultaneously. The maximum span is 12.8 kHz. While input circuitry for each channel is separate, hardware for digital filtering, zooming, and trigger detection and delay is common to all eight inputs. Thus, parameters such as measurement span and trigger delay are the same for all channels.

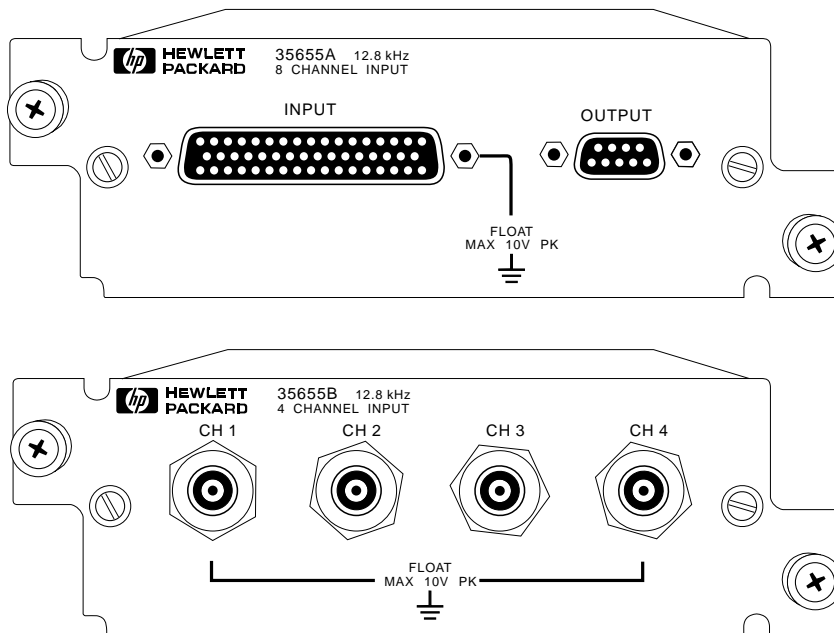

Other module features include:

- Two input modes: voltage and IEPE constant-current
- Full scale input ranges from 5 mV to 10 V in 2 dB steps
- Anti-alias protection on all spans
- Auto-ranging
- Digital zoom capability on all channels and all spans
- 72 dB dynamic range
- Buffered analog output on all input channels

* NOTE: The IEPE mode provides a 2.4 mA constant current supply for transducers. To operate with the HP 35655A module, IEPE transducers must be isolated from ground.

The HP 35655A module comes with one eight-input BNC breakout box (6 ft cable), one eight-output BNC breakout box for the analog outputs and a rack mount kit (HP 35655-00200). Option 905 substitutes microdot breakout boxes.

An HP 46298C 1600mm rack is recommended to house rack-mountable breakout boxes for HP 35655A input modules. An HP 46298C rack can hold up to 16 rack panels (equivalent to 256 channels). A special eight vertical slot rack kit (HP 35655-C02) is also available.

Specifications:

NOTE: HP 35655A input performance specifications apply only if the module's analog output is turned off (default is off). All specifications are measured at module front panel connector.

Frequency

Range: dc to 12.8 kHz

Spans and block sizes: see page 4

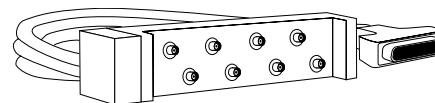

BNC breakout box
35655 - 61600 BNC
35655 - 61601 micro dot

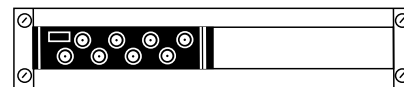

The HP 35655-00200
shown with one
breakout box installed

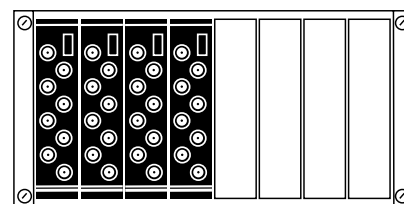

The HP 35655-C02
shown with four
breakout boxes
installed

HP 35655A 8-Channel Input Module

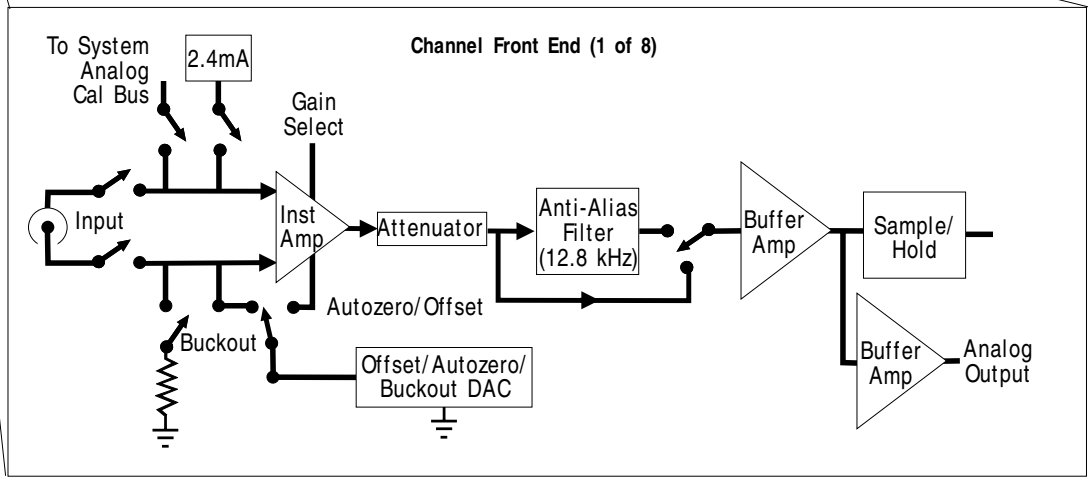
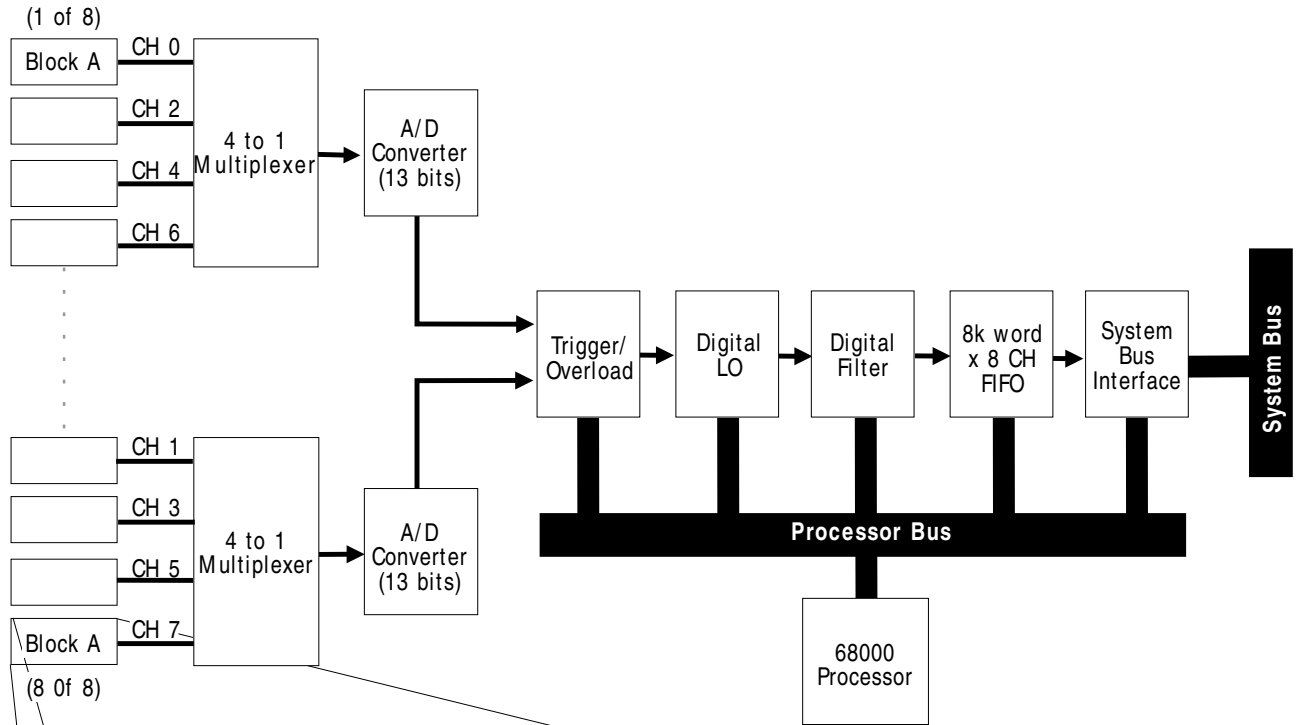

HP 35655B 4-Channel Input Module

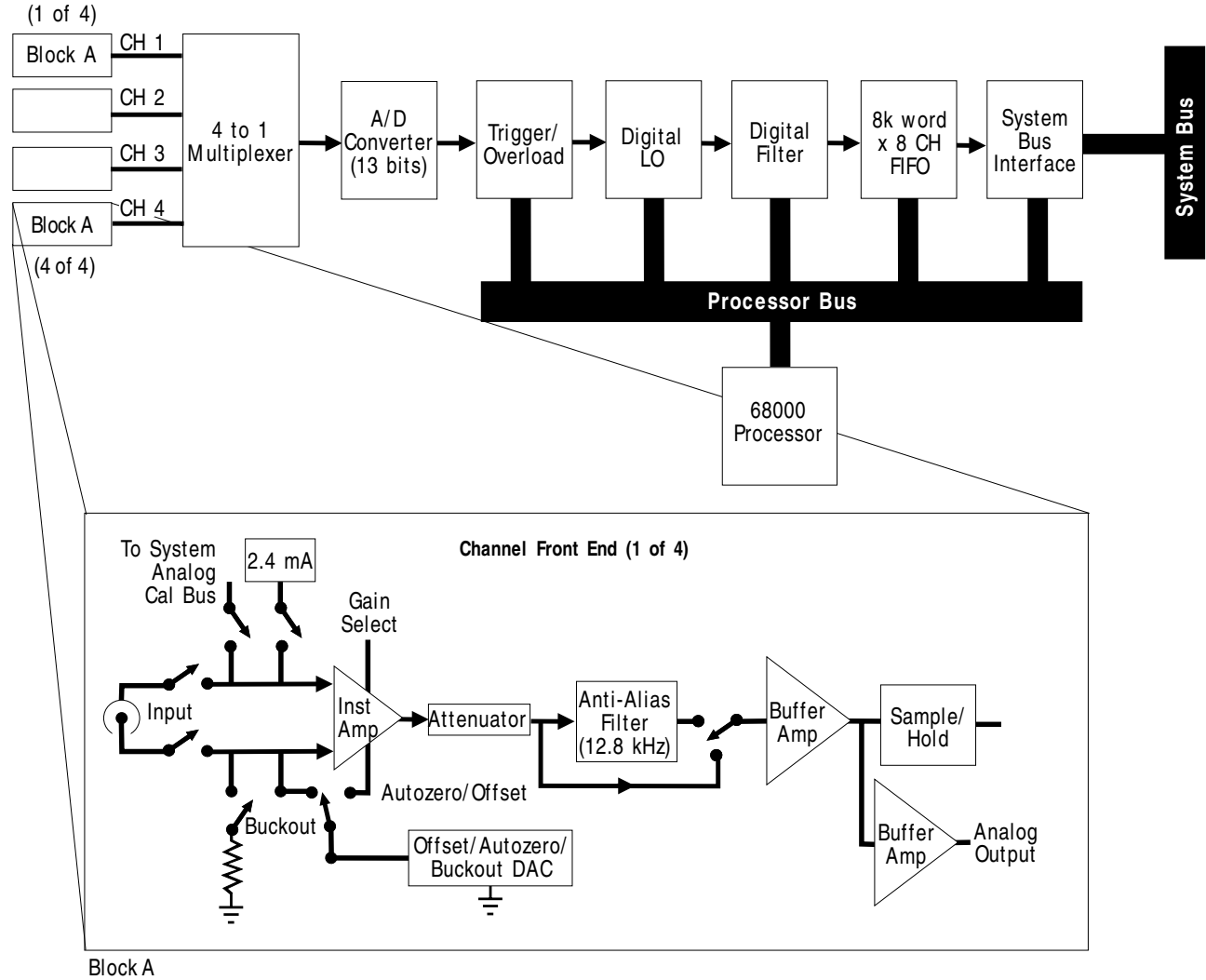

Voltage Input Accuracy

Single-Channel Amplitude:
(relative to 1 kHz full scale sine wave input)

Calibrated with HP 35653C source cal signal and calibration routine available with HP 35630B and HP 35635R software

Frequency	Input Range	Accuracy
All	20 dBVp to -46 dBVp	± 0.15 dB

Uncalibrated; after software correction of digital filter characteristics

Frequency	Ranges	Accuracy
30 Hz to 2 kHz	All Ranges	± 1.05 dB
2 kHz to 12.8 kHz	All Ranges	± 1.8 dB

Channel-to-Channel Amplitude and Phase Accuracy:

Calibrated with HP 35653C source cal signal and calibration routine available with HP 35630B and HP 35635R software

Amplitude	Phase
± 0.1 dB	± 0.5 degree

Uncalibrated; after software correction of digital filter characteristics

Frequency	Ranges	Accuracy
1 kHz	All Ranges	.25 dB nominal

Phase: (signal level > -40 dBfs, at 1 kHz) ±1.0 degree

Full Scale Range: 5 mVpk (-46 dBVp) to 10 Vpk (+20 dBVp) in 2 dB steps

Input Resistance (IEPE source off, dc coupled or ac coupled above 1 Hz) High or low to case, differential mode: 1 MΩ ±5%

Input Capacitance (IEPE source off) High or low to case: <200 pF

AC Coupling: 3 dB ac rolloff <1 Hz

Common Mode Rejection Ratio (dB):
(Rs = 0Ω, differential mode)

Frequency	Input Ranges	Accuracy
0 to 66 Hz (dc coupled)	-46 to -22 dBVp -20 to -2 dBVp 0 to +20 dBVp	>80 dB >74 dB >58 dB
66 Hz to 1 kHz (dc coupled)	-46 to -22 dBVp -20 to -2 dBVp 0 to +20 dBVp	>60 dB >50 dB >34 dB
47 to 66 Hz (ac coupled)	All Ranges	>45 dB

Dynamic Range: 72 dB
(16 averages, Rs = 50Ω, common mode signal < +20 dBfs)

Harmonic Distortion:
(relative to full-scale sine wave input)

Ranges	Frequency	Accuracy
-46 to +8 dBVp	All (internal sampling) All (external sampling)	<-72 dB <-60dB
+10 to +20 dBVp	<1.3 kHz (internal sampling) <1.3 kHz (external sampling) >1.3 kHz	<-72 dB <-60 dB <-154 + 20 Log (freq)+range dB

Intermodulation Distortion:
(relative to two -6.02 dBfs in-band sine wave input signals)

Ranges	Frequency	Accuracy
-46 to +8 dBVp	All (internal sampling) All (external sampling)	<-72 dB <-60 dB
+10 to +20 dBVp	<2.6 kHz (internal sampling) <2.6 kHz (external sampling) >2.6 kHz	<-72 dB <-60 dB <-160 +20 Log (freq)+range dB

Channel-to-Channel Crosstalk (50Ω source, 50Ω termination on all unused channels, relative to full scale signal on offending channel):

IEPE Current Source Off:
<MAX(-72 dBfs, -123 dB)
IEPE Current Source On:
<MAX (-72 dBfs, -110 dB)

Autozero Modes: see
HP 35652A/B specifications
on page 12.

Common Mode Range (differential mode): Absolute maximum signal level of either high or low terminal, with respect to chassis, including signal, common mode voltage, and noise shall not exceed: ±10 Vpk

Spurious or Residual Responses: (in-band input signal, full scale)

Int. Sample Clock: <-72 dBfs
Ext. Sample Clock: <-60 dBfs

Transducer Power Supply

Current: 2.4 mA nominal
(into 50 Ω)

Maximum Voltage: 24 V nominal,
relative to shell of BNC

Note: IEPE transducer must be isolated from ground to achieve +24 volts open circuit. When IEPE is turned on, the shell of the BNC is pulled to -10 volts, requiring ground isolation of the transducer.

Analog Output

Output Level for Any Full-Scale
Input: 2 Vpk nominal

Output Impedance: 2 kΩ

Noise (measured on most sensitive range):

20 to 1000 Hz (frequency dependent): <2260/√(f) nVrms/√(Hz)
>1000 Hz (frequency independent): <70 nVrms/√(Hz)

Abbreviations

The following abbreviations are used in the previous specifications:

dB - decibel

dBVp - dB relative to 1 volt peak

dBfs - dB relative to full scale

nVrms/√Hz - nano-volts rms per square root hertz

fs - full scale

Rs - resistance of source or termination connected to an input

Vs - voltage level of source connected to an input

MAX(x,y) - the specification is the greater of the two values, x and y

HP 35653C Source Module

The HP 35653C source module provides the excitation signals needed for a wide variety of stimulus/response measurements. The module's output modes include:

- An uncorrelated band-limited and band-translated random noise stimulus
- A variable burst random stimulus
- Burst sine (single frequency) and impulse outputs
- A reference signal for system calibration of input modules
- Programmable phase control at 0°, 90°, 180°, 270°
- Hard-wired switch to guarantee 100% compatibility with the obsolete HP 35653A

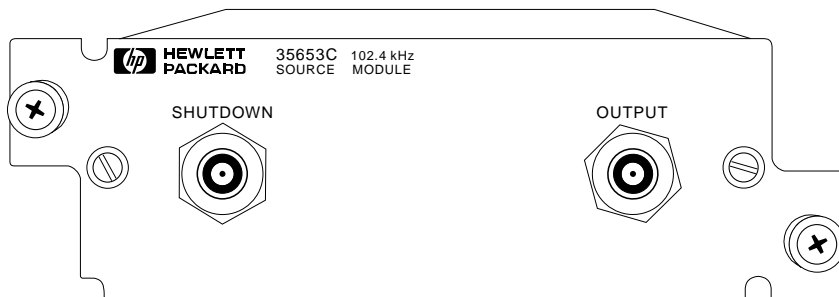

Specifications:

Amplitude

Output Level

AC Range: 1.26 mV (-58 dBVp) to 10.0V (+20 dBVp) in 0.375 dB steps

Maximum Output Voltage: (ac + dc) 10 V (RL > 10 k Ω)

Maximum Current: > 50 mA (-8 V < V_{out} < +8 V)

Accuracy

$\pm 10\% \pm 10$ mV: 1 kHz sine, RL > 10 k Ω , from 100 mVpk (-20 dBVp) to 10 Vpk (+20 dBVp)

DC Offset (RL > 10 k Ω)

Range: ± 5 V

Resolution: 2.5 mV

Accuracy: ± 20 mV $\pm 1\%$ of V_{out} (at 25°C)

Output Impedance: <1.2 Ω

Capacitive Load: 0.01 μ F max

Random Noise Modes

Passband Flatness: ± 3 dB

In-Band Energy: 70% (amplitude = 10 Vpk, center frequency = 5 kHz, span = 800 Hz)

Crest Factor:

5 (typical; baseband)

7 (typical; zoomed, center frequency > 70% of span)

Fixed Sine Mode

Flatness: ± 1 dB (relative to level at 1 kHz, ranges ≤ 16 dBVp); +1, -3 dB (relative to level at 1 kHz, ranges ≤ 16 dBVp)

Harmonic and Subharmonic

Distortion (for signals > 1 volt): < -35 dB

Pulse Mode

Pulse width: 1% to > 95% of time record (typical; minimum pulse width, block size of 1024 points)

Abbreviations

RL - Load resistance on HP 35653C output

dBVp - dB relative to 1 volt peak

HP 35653C Source Module

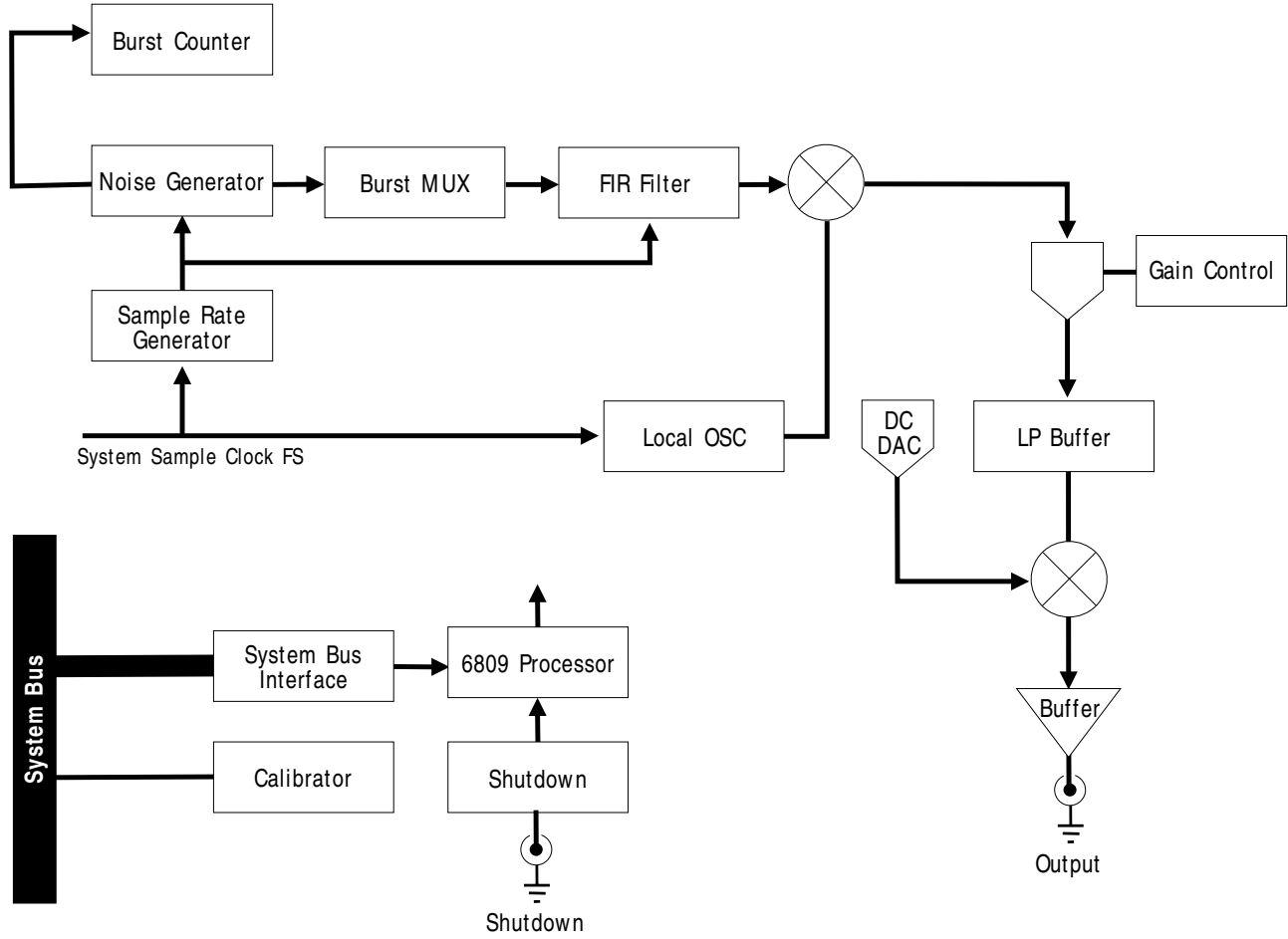

HP 35656B Programmable DAC Module

The HP 35656B is a digital-to-analog (DAC) source module that can be programmed to generate user-defined signals. Module features are tailored to vibration control applications:

- Signal DAC with 16 bits of resolution
- Programmable range DAC (16-bit resolution)
- Programmable data buffer size (from 1 to 32,768 datawords)
- Programmable sample Δt from 4 μsec to 64 sec
- Programmable output attenuators (0 dB, -20 dB, -40 dB)

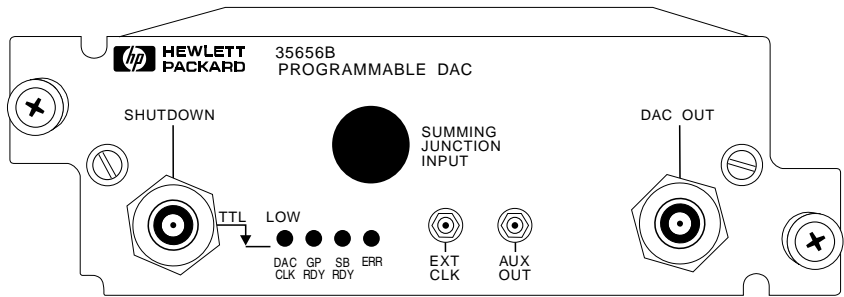

- DC offset (after autozero): $< \pm 2 \text{ mVolts}$
- Source rampdown time of approximately 1.5 sec
- System shutdown via the external TTL port or internal system bus
- External parallel interface to allow downloading of data directly from the host computer

Specifications

Signal Output

Max. Voltage Level: $\pm 10 \text{ Vpk}$
 Max. Current: $\pm 50 \text{ mA}$
 Max. Output Impedance: 1.2Ω
 Max. Capacitive Load: $0.01 \mu\text{F}$
 Output Range: 0.1 Vp to 10 Vp

HP 35656B Block Diagram

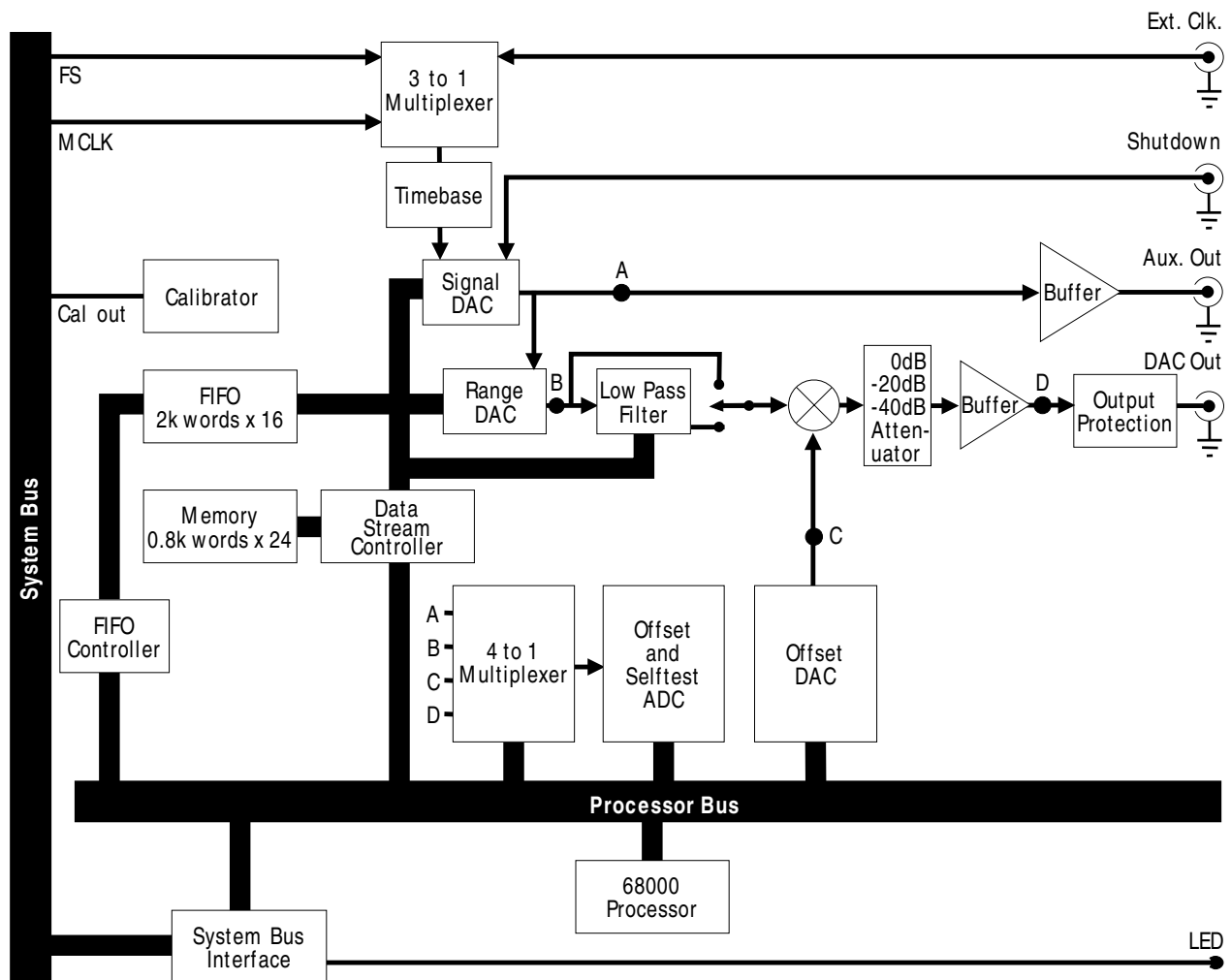

HP 35658A Tachometer/Trigger Module

The HP 35658A tachometer/trigger module provides tach and triggering information for use with digital order tracking and resampling software. The module uses a 20 MHz counter to record accurate tach or trigger times. It can also be use to externally trigger other measurements.

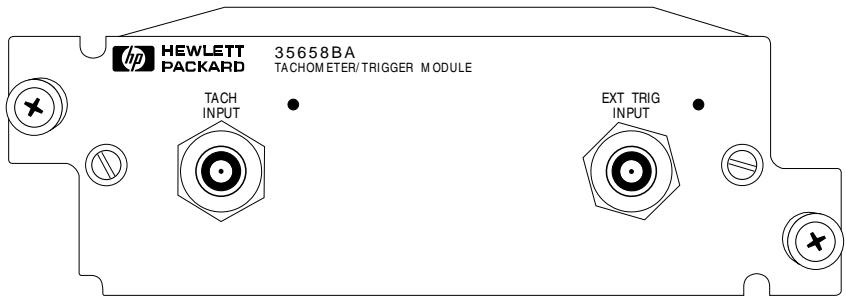

- Tachometer/trigger signal conditioning
- Programmable tach/trigger levels
- Hysteresis to prevent false tachs/triggers
- Trigger sources: time internal, RPM internal, (run-up or run-down), external

Specifications

Tach Pulses/Revolution: 0.00001 to 65,536
RPM Accuracy: ±100 ppm
RPM Range: 0.25 to 6,000,000 rpm
Tach Pulse Rate:
 min: 4.762 mHz
 max: 100 kHz

Tach/Trigger level

Range: -25 V to + 25 V
 Resolution: ≤ 5 V: 40 mV
 > 5 V: 200 mV
 Accuracy: ≤ 5 V: ±100 mV
 > 5 V: ±5% ±0.5 V
 Input Impedance: > 20 k (typical)

Min. Trigger pulse width: 100 ns

Tach Hold Off Time:

min: 4.8 μs (1.6 μs steps)
 Max: 50 ms (1.6 μs steps)

HP 35658A Block Diagram

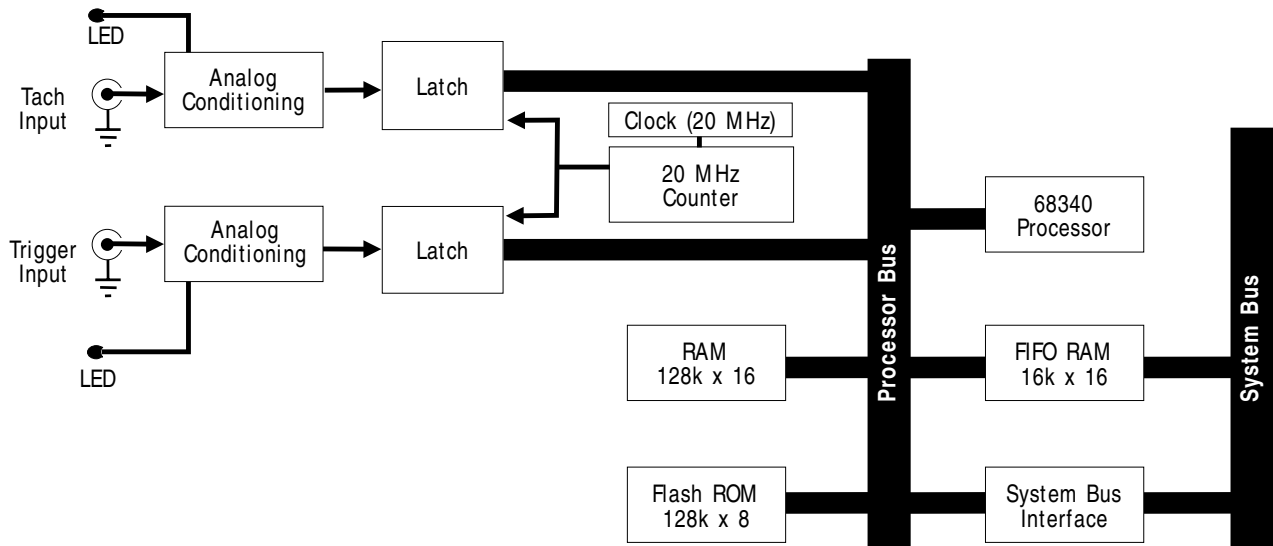

HP 35659A SCSI Interface Module

The HP 35659A module provides high-speed throughput capability for the HP 3565S system. Bypassing the signal processor module, it takes data from the internal high-speed system bus and transfers it directly to selected Small Computer System Interface (SCSI) compatible mass-storage devices or to an optional internal hard disk. The module supports transfer rates up to 2.6 MBytes/sec (1.3 Msamples per sec). The actual data transfer rate is typically limited by the storage device.

Features include:

- "Eavesdrop" mode takes data directly from the system bus while the signal processor module uses its HP-IB connection for other tasks.
- Monitor capability allows data to be viewed during the throughput session.
- Read mode takes data from SCSI compatible devices and puts it on the internal system bus for the signal processor module to process.

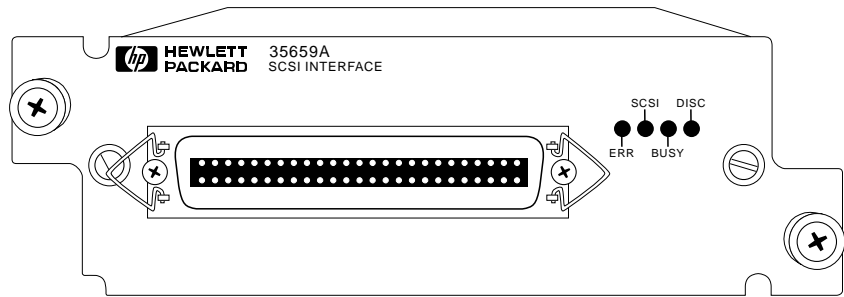

- Multiple HP 35659A modules can be installed in a system to increase the maximum storage size. Up to eight modules may be in a system.
- The maximum system transfer rate is 2.6 MBytes/sec, or 1.3 Msamples/sec with option AT3.
- An optional internal 1 GByte hard disk, option AT3, is fully contained inside the module. It functions as a target on the SCSI network.

Option AT3: Internal Hard Disk
 Type: Magnetic Hard Disk
 Size: 1 Gbyte (500 Msamples)
 Throughput rate: 1.3 Msamples/sec (2.6 Mbytes/sec)

Supported SCSI Mass Storage Devices:

Model	Type	Size	Max Rate*
HP 7979S	Mag	323 MB	0.7 MB/s
HP C2214B	Mag	1.3 GB	2.0 MB/s
HP C1520B	Tape	2.0 GB	100 kB/s
HP C1521B	Tape	8.0 GB	100 kB/s

* Transfer rates typical

SCSI Cables:

HP 92222A - 0.5 meter
 HP 92222B - 1 meter
 HP 92222C - 2 meters
 (maximum cable length is 6 meters)

HP 35659A SCSI Interface Module

