

HP 85071B Materials Measurement Software

Technical Data

Measure ϵ_r^* and μ_r^* over a wide frequency range

The HP 85071B materials measurement software determines the intrinsic electromagnetic properties of many dielectric and magnetic materials. The complete system is based on a versatile network analyzer which measures the material's response to RF or microwave energy.

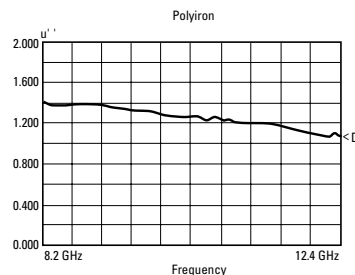
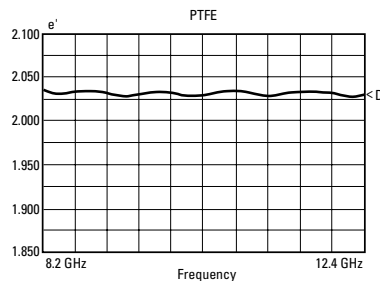

Examine the properties of materials across the RF and microwave frequency spectrum.

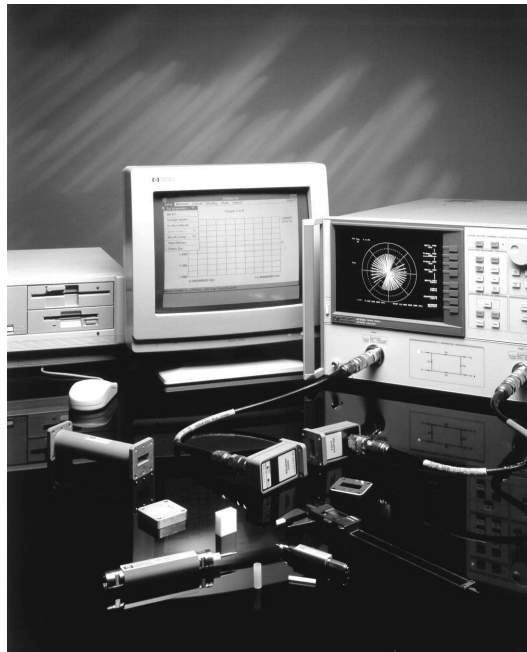

Small samples of the material under test (MUT) are machined to fill the cross section of coaxial or waveguide transmission lines and measured within the fixture. Or large, flat samples are placed between antennas and measured under free space conditions.

The HP 85071B software controls the network analyzer and calculates the complex permittivity ϵ_r^* (or dielectric constant) and permeability μ_r^* , including the loss factor or loss tangent. Results are displayed as a function of frequency, with 1 to 2% accuracy (typical). Depending on the HP network analyzer and fixture used, measurement frequencies can extend from 100 MHz to 110 GHz.

Flexible and easy to use

The HP 85071B runs on your choice of computer platforms: The standard version of software requires an HP Vectra PC and has a friendly mouse-driven user interface. Option 300 substitutes an HP BASIC version of the software and requires an HP 9000 Series 300 controller. The BASIC code is modifiable.

New HP 85071B features

- Improved Nicolson-Ross model provides sample position invariance.
- New one-port arbitrary backed model measures thin samples accurately.
- Air gap correction improves the accuracy of transmission line methods.
- Compatibility with free space measurements.
- Simpler user-interface.

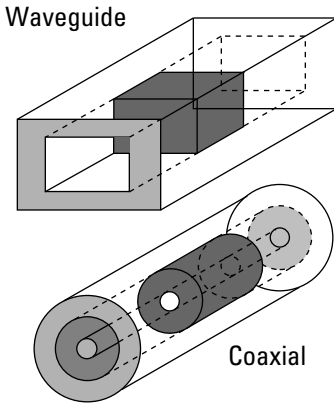

Simple coaxial or waveguide transmission lines hold the samples of material under test.

Transmission line method

Coaxial airlines or rectangular waveguide transmission lines can be used as sample holders. Solid samples that can be precisely machined to fit inside the fixture give the best results.

The HP 85071B features an algorithm that corrects for the effects of air gap between the sample and fixture, which can be the largest source of error with a transmission line technique.

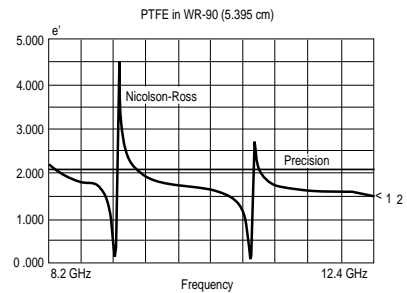

Air gap correction algorithms increase the accuracy of measurements made in a transmission line media.

Free space method

Large, flat samples of materials can be placed between antennas to measure their properties in a non-contacting fashion. Because the sample is not contained in a fixture, the error from air gap is not a concern. Free space is best when measuring materials that must be heated to very high temperatures or when measuring a large area of a

material which is non-uniform (i.e., honeycomb, composite).

A TRL or TRM (Thru-Reflect-Line or Match) calibration is ideal under free space conditions with a full S-parameter test set configuration. Time domain gating can also be used to remove mismatch effects.

Antennas direct beams of microwave energy at or through a material, without enclosing it in a fixture.

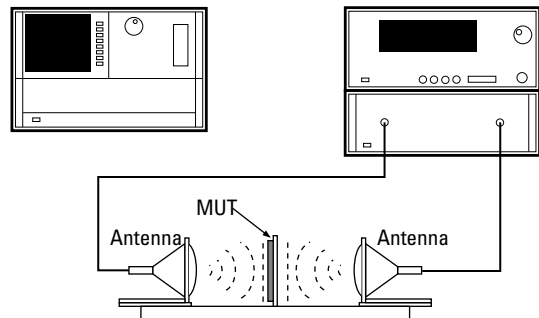

Wide range of models

The HP 85071B has five different algorithms to choose from, each with specific benefits:

The traditional method has been described by Nicolson-Ross, Weir and HP Product Note 8510-3. It is best for magnetic materials such as fer-rites and absorbers. It calculates both ϵ_r^* and μ_r^* , including loss, from a two-port measurement of a single sample. You get results quickly and easily.

The HP 85071B also includes two other two-port algorithms for non-magnetic materials ($\mu_r^*=1$). These models do not suffer from discontinuities at frequencies where the sample length is a multiple of half-wavelengths. These models are used to measure long, low-loss materials with greater accuracy.

While the two-port algorithms are best for most solid materials, one-port algorithms provide a simple calibration and measurement and are better suited to measurements of liquids and powders. A shorted waveguide can be turned on end and filled with a material. One-port

fixtures are also better suited to high-temperature measurements where one end of the fixture can be heated, while cooling mechanisms at the other end protect the network analyzer.

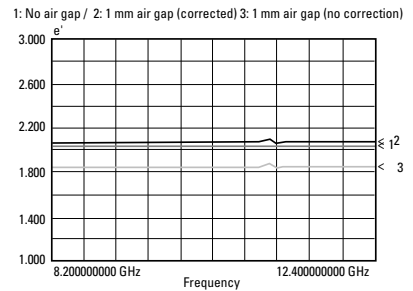

Traditional methods produce spurious data at periodic frequencies. With the HP 85071B you get accurate data at all frequencies.

Although one-port fixtures are usually terminated with a short circuit, the HP 85071B also accommodates an arbitrary termination which produces more reliable results for thin samples.

Performance characteristics

Specifications describe the warranted performance over the temperature range 0° to 55°C. **Supplemental characteristics** are intended to provide information useful in applying the instrument, by giving typical but non-warranted performance parameters. These are denoted as “typical,” “nominal,” or “approximate.”

Frequency range (typical)

100 MHz to 110 GHz depending on network analyzer, fixture and material.¹

Accuracy (typical)

1 to 2%

Transmission line fixtures

Coaxial fixtures (beadless airlines) are broadband but require a sample shaped into a flat-faced torus. Wave-guide fixtures are band-limited but operate at higher frequencies and accept a simpler rectangular shape.

Samples must completely fill the cross section of the transmission line without gaps at the fixture walls. Faces at either end must be flat, smooth and perpendicular to the long axis.

Free space systems

Large, flat, thin, parallel-faced samples are placed between antennas and measured under free space conditions.

Antennas should maintain a planar “far-field” wavefront to the sample².

Material under test assumptions

Material is homogeneous (uniform composition) with no layers³. Non-isotropic (uniform orientation) materials can be measured in waveguide.

Software features

Setup

Select frequency range, number of points, linear or log sweep; select model; define sample holder; apply air gap correction; verify estimate; save/recall test conditions and calibrations; select full/short menus for different levels of user-interface complexity.

Calibration

Performed manually on the network analyzer; use any error-correction technique supported by the network analyzer.

Measure

Trigger measurement; recalculate without re-measuring the MUT; title measurement; forward measurements only for one path two-port measurements using transmission/reflection test sets; retrieve measurement without verifying the existence of a calibration (i.e., time domain gating applied).

Format

ϵ_r' , ϵ_r'' , $\tan \delta$, μ_r' , μ_r'' , $\tan \delta_m$ or Cole-Cole plots; tabular listings of data.

Display

Display current measurement data; save/display up to 3 memory traces; compare data to reference trace using trace math.

Scaling

Set graticule scale factor or “autoscale.”

Output

Hardcopy plots to plotters or graphics printers; tabular listings to printers; save/recall/export data via disk in MS-DOS® ASCII format or HP BASIC BDAT format (HP LIF binary).

Software models

Model Name	Measured S-parameters	Number of Samples	Optimum Sample Thickness ⁴	Results	Comments
Refl/Tran u&e N-R (Nicolson-Ross)	$S_{11}, S_{21}, S_{12}, S_{22}$ (or S_{11}, S_{21})	1	$\lambda_g/4$	ϵ_r^* & μ_r^*	Fast, but has $n\lambda/2$ discontinuities. Best for magnetic, short or lossy MUTs.
Refl/Tran e Prec'n (NIST Precision)	$S_{11}, S_{21}, S_{12}, S_{22}$	1	$n\lambda_g/2$	ϵ_r^*	Accurate, no discontinuities. Best for long, low-loss MUTs.
Refl/Tran e Fast (Fast)	$S_{11}, S_{21}, S_{12}, S_{22}$ (or S_{11}, S_{21})	1	$n\lambda_g/2$	ϵ_r^*	Similar to Precision but faster and better for lossy MUTs. Best for long, low-loss MUTs.
Refl e Short-Back (Short-backed)	S_{11}	1	$\lambda_g/2$	ϵ_r^*	Best for liquids or powders.
Refl e Arbit-Back (Arbitrary-backed)	S_{11}	1	$\lambda_g/2$	ϵ_r^*	Best for thin films.

¹Minimum frequency is set by the maximum practical sample length (L): f (in GHz) > $\frac{1}{\sqrt{\epsilon_r' \mu_r'}} \frac{30 \text{ cm}}{L \text{ (in cm)}} \frac{20}{360}$

²Antenna should be placed $\approx 2d^2/\lambda$ from the sample, where d is the larger of the antenna or sample diameter.

³If the material is not homogeneous through the length of the sample (i.e., layers), the reflection from the front (S_{11}) and back (S_{22}) face will be different and will lead to a potentially erroneous result. If the material is not homogeneous across the face of the sample, the result is an average value over the cross section that is exposed to the EM field (weighted by the intensity).

⁴Where: $\lambda_g = \frac{1}{\sqrt{\epsilon_r' \mu_r' - \frac{1}{\lambda_c^2}}}$ $\lambda_c =$ cutoff frequency (omit for coaxial) and λ_o (in cm) = $\frac{30}{\text{frequency (in GHz)}}$

Ordering information

HP 85071B materials measurement software

MS-DOS® software is standard. Requires a controller, network analyzer and fixtures or antennas to complete the system (see table of compatible components below).

Option 300 **Substitutes HP BASIC software**

Compatible components

	HP 85071B standard software (MS-DOS® version)	HP 85071B Option 300 software (HP BASIC version)
	Program is compiled and not modifiable. 3.5-inch disk format (MS-DOS®)	Program is 90% modifiable. 3.5-inch disk format (HP LIF).
Controller	HP Vectra 386 or 486 with 3.5-inch floppy disk drive, >20 MByte hard drive, >2 MByte RAM, coprocessor (recommended), IEEE-488 interface card/library (HP 82335B HP-IB interface or National Instruments AT-GPIB, GPIB-II or GPIB-IIA interface). Requires MS-DOS® version 3.20 or higher and Microsoft Windows® 3.0 or 3.1.	HP 9000 Series 300 or 9816 or 9836 with >700 kByte 3.5-inch floppy disk drive, >2 MByte RAM. Requires HP BASIC operating system 5.0 or higher.
Network analyzer	HP 8752A (300 kHz to 1.3 or 3 GHz) Transmission/reflection test set is limited to S ₁₁ and S ₂₁ measurements only. HP 8753C (300 kHz to 3 or 6 GHz) HP 85044A transmission/reflection test set is limited to S ₁₁ and S ₂₁ measurements only. HP 8719A/C, 8720A/B/C or 8722A (50 or 130 MHz to 13.5, 20 or 40 GHz) HP 8510B/C (45 MHz to 110 GHz, depending on source and test set) Compatible with synthesized source-based HP 8510B/C systems with firmware revision 5.0 or higher. Not compatible with HP 8350 sweeper-based systems. Upgrade HP 8510A systems using HP 85103C performance upgrade package.	
Transmission line fixtures and accessories	Waveguide airlines <i>HP 11644A-series waveguide calibration kits contain a 1/4 wavelength line and a straight section which can also be used as sample holders. Contact HP for information on third party suppliers of other waveguide transmission lines.</i> Coaxial airlines <i>HP 8505X-series coaxial verification kits contain airlines that can also be used as sample holders. Contact HP for information on third party suppliers of other coaxial transmission lines.</i> Accessories <i>Test port cables to connect fixture to network analyzer; adapters (as needed) to adapt cables to fixture; calibration kit to match connectors on fixture.</i>	
Free space antennas and accessories	Antennas <i>Contact HP for information on third party suppliers of free space antennas.</i> Accessories <i>Cables to connect antennas to network analyzer; adapters (as needed) to adapt cables to antennas; free space calibration standards</i>	

HP 85078A upgrade kit

Upgrades the HP 85071A to the full capabilities of the HP 85071B.

Option 071 **Upgrade kit for HP 85071A to HP 85071B standard (MS-DOS®)**
Option 371 **Upgrade kit for HP 85071A to HP 85071B Option 300 (HP BASIC)**

HP 85079B software update

Updates the HP 85071B software to the most current version. Contact HP for details.

Option 071 **Updates the HP 85071B standard (MS-DOS®) software**
Option 371 **Updates the HP 85071B Option 300 (HP BASIC) software**

For more information, call your local HP sales office listed in your telephone directory.

**Prices and
Data Subject to Change
Copyright © 1993
Hewlett-Packard Company
Printed in U.S.A. 1/93
5091-6248E**