

- Advanced dynamic control
- 100 ns frequency agility
- 40 MHz instantaneous modulation bandwidth
- Arbitrary control over AM, FM,  $\Phi$ M, pulse, and frequency hop
- Easy-to-use application-specific software
- Precise synthesized signal control
- Standalone or subsystem operation
- 40 GHz operation with optional upconverters
- Phase-coherent frequency hopping

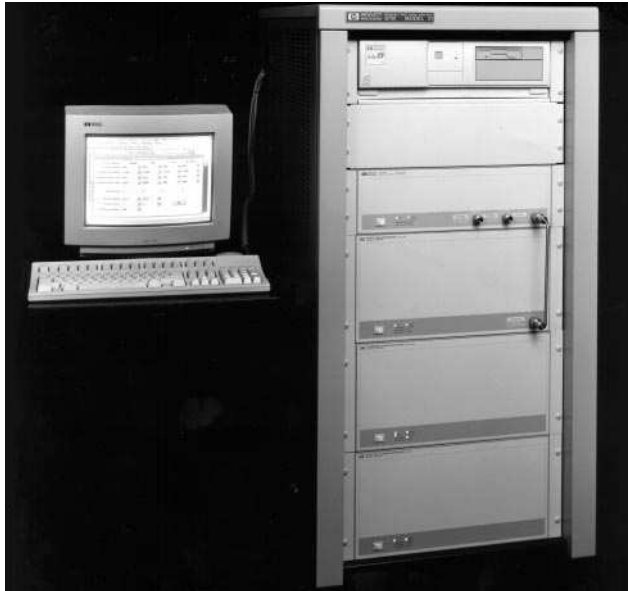

HP 8791 Model 11 with optional external upconverter

**HP 8791 Model 21 (0.05 to 18 GHz),  
HP 8791 Model 11 (10 to 3000 MHz),  
HP 8791 Model 7 (DC to 50 MHz).  
Frequency Agile Signal Simulators**



### High-Precision Signals for EW, Radar, and Advanced Communications

The HP 8791 family of Frequency Agile Signal Simulators (FASS) generate the complex yet realistic test signals needed for today's sophisticated signal simulation and system test. Whether you're simulating advanced EW threats, radar target returns, satellite transponder traffic, or cellular radio's multiple-signal environments, FASS combines powerful modulation capability with digitally-generated signal precision. The 40 MHz instantaneous modulation bandwidth can be switched anywhere across the 0.05 to 18 GHz coverage of Model 21 (3 GHz for Model 11) in 100 nanoseconds to generate spread spectrum formats, radar chirps, video, pseudo-noise, multiple carriers, QAM and FSK. Comprehensive application software harnesses the power of FASS, giving the system an easy-to-use, mouse-driven front panel.

Application-specific Instrument-on-a-Disk (ID) software includes the HP 8791 Model 100 precision signal generator which provides quick access to all FASS modulation and signal capability in the easy-to-use format of a traditional signal generator. The Model 200 radar simulator features various pulse modulations and antenna scans that simplify radar target return simulations. Optional upconversion extends FASS coverage to 40 GHz.

### Description

The Frequency Agile Signal Simulator uses high-speed memory, signal processing, digital-to-analog conversion and direct digital and analog synthesis for precise signal simulation with unprecedented flexibility. The Frequency Agile Signal Simulator is characterized by:

- High-performance modulation and agility
- Instrument-grade quality, repeatability, accuracy
- Easy-to-use, software-reconfigurable user interface
- Low cost of ownership
- Off-the-shelf instrumentation

The modulation data source's digital memory and sequencers store signal characteristics, namely carrier frequency and hop patterns, amplitude, frequency, phase and pulse modulation data. This data is supplied to the agile carrier synthesizer, where it is processed and converted to an analog signal made up of a carrier and its modulation. Model 7 outputs this dc to 50 MHz signal directly, while Model 11 translates it anywhere between 10 and 3000 MHz using the agile upconverter. A second agile upconverter, used in the HP 8791 Model 21 FASS, translates the signal between 0.05 and 18 GHz. The smart interface manages data flow and signal generation functions within FASS, as specified by inputs from its menu-driven front panel or over HP-IB.

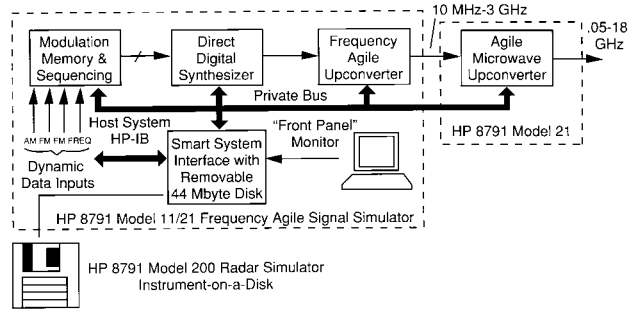

HP 8791 Models 7, 11, 21, 100, 200

### Application Overview

### Electronic Warfare

FASS is ideal for simulating advanced threats with intrapulse modulation, PRI stagger, frequency agility and antenna scan modulation. Being fully synthesized, FASS is especially well suited for pulse Doppler radar simulation.

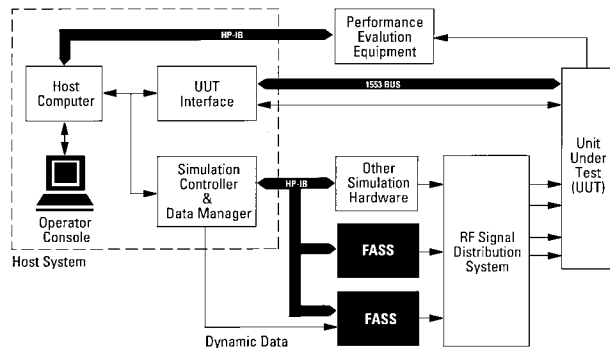

### Communications

FASS can produce a variety of sophisticated signals for testing satellite, terrestrial, and mobile communications systems and components. In parametric testing, FASS's high clock rate, frequency agility and digital precision can significantly shorten test times for tests like NPR, group delay and gain flatness. More importantly, FASS can simulate actual link traffic and signal environments, increasing accuracy and realism while eliminating the need for time-consuming and costly field testing. Link FASS with your computer simulation software to generate production test signals identical to the test vectors used in your design simulations. Add signal impairments and propagation effects to evaluate system operating margins. Complex signals like TDMA and CDMA are easily generated using FASS dynamic sequencing.

### Radar

FASS can simulate target returns for testing and calibrating radar receivers. FASS can also be used as a major subsystem for instrumentation radars, serving as a complex waveform exciter or a frequency agile STALO for coherent systems.

### Modes of Operation

#### Instruments-on-a-Disk (IDs)

Instruments-on-a-Disk (IDs) make this otherwise complex system easy to use and give FASS the front panel personality of specific applications. By clicking clearly-labeled softkeys with the mouse, users can modify sophisticated signal characteristics like PRI stagger quickly and easily.

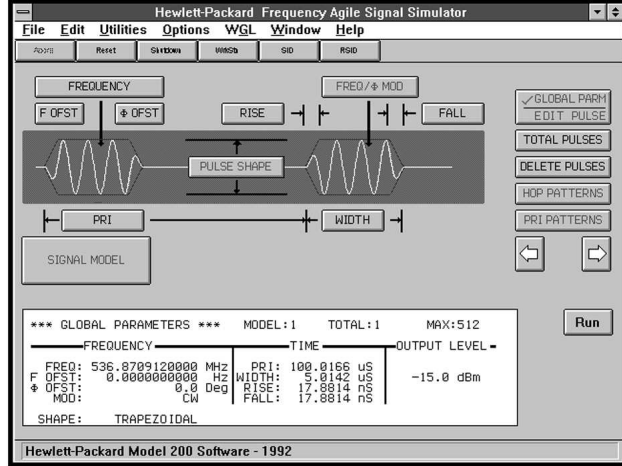

HP 8791 Model 200 screen

#### Remote HP-IB

Remote HP-IB commands in FASS come in two varieties. There are the commands that mimic front-panel keystrokes of an ID and the general-purpose commands that give access to all the functions of FASS. Whichever set of standard HP-IB commands is used, integrating FASS's high-integrity, advanced signal simulation capability into an existing simulation system is very convenient.

#### Waveform Generation Language (WGL)

For advanced applications where existing ID software is insufficient, users can program FASS with the Waveform Generation Language (WGL) software. WGL could be used to generate nonstandard signals such as nonlinear chirps or complex signal environments such as TDMA or CDMA.

#### Dynamic Data/Dynamic Sequence

Dynamic data mode allows selective, external control of instantaneous frequency, FM,  $\Phi$ M, and AM, as well as pulse modulation and level. In dynamic data mode, data maps are downloaded to the modulation data source's frequency and modulation memories. Dynamic data supplied at rates of up to 33 MHz addresses desired locations in memory. The output of FASS is determined by the values mapped at that location. Dynamic sequence allows external real-time selection of up to 1024 unique waveform sequences.

### Performance Characteristics

#### HP 8791 Model 21 Frequency Agile Signal Simulator

##### Frequency

**Range:** 0.05 to 18 GHz (to 40 GHz with upconversion)

**Resolution:** 0.125 Hz

**Switching Speed:** < 100 ns typical over full 18 GHz BW

##### Amplitude

**Fast-Level Control Switching Speed:** < 100 ns typical in 6.02 dB steps

**Output Power:** +10 to -107 dBm

##### Modulation Capabilities

**Instantaneous Bandwidth:** 40 MHz

**Formats:** Arbitrary FM,  $\Phi$ M, AM, Pulse, Frequency Hopping

##### Spectral Purity

**Spurious Response:** -55 dBc, typical

**Phase Noise:** < -110 dBc/Hz @ 10 kHz offset, 9.77 GHz, typical

##### Remote Operation

##### HP-IB compatible

**Dynamic Data:** AM, FM,  $\Phi$ M, carrier frequency, pulse

**Dynamic Data Rates:** Up to 33 megawords/sec/channel

##### General

**Size:** Rack: 600 mm W x 1237 mm H x 803 mm D (23.6 x 48.7 in x 31.6 in); console: 754 mm W x 1064 mm H x 756 mm D (29.7 in x 41.9 in x 29.8 in)

**Weight:** Shipping, rack 319 kg (700 lb); console 75 kg (165 lb)

#### HP 8791 Model 11 Frequency Agile Signal Simulator

Same specifications as Model 21 except:

**Frequency Range:** 0.01 to 3 GHz (to 18.5 GHz with upconversion)

**Switching Speed:** < 100 ns typical over full 3 GHz BW

#### HP 8791 Model 7 Frequency Agile Signal Simulator

Same specifications as Model 21 except:

**Frequency Range:** DC to 50 MHz (other output frequencies available using external upconverters)

**Switching Speed:** 8 ns to within  $10^\circ$  of final frequency

##### Amplitude

**Output Power:** +10 to -100 dBm

##### Spectral Purity

**Phase Noise:**  $\pm$  127 dBc/Hz at 10 kHz offset at 40 MHz typical

**Instantaneous Modulation BW:** 50 MHz p-p

**Weight:** Shipping, rack 258 kg (568 lb); console 75 kg (165 lb)

#### HP 8791 Model 100 Precision Signal Generator

The HP 8791 Model 100 Precision Signal Generator Instrument-on-a-Disk (PSID) software configures FASS to be a high-precision signal generator.

**Carrier:** Amplitude, phase, frequency

**AM:** Modulation index: 0 to 100% (80 dB DSB-SC);

Modulation frequency: 0.0625 Hz to 20 MHz

**PM:** Peak phase deviation:  $0^\circ$  to  $180^\circ$ ;

Modulation frequency: 0.0625 Hz to 20 MHz typical

**FM:** Frequency deviation: 0.125 Hz to 20 MHz;

Modulation frequency: 0.0625 Hz to 20 MHz;

0 to approximately 2 MHz typical

##### Modulation Waveforms

**Sine:** AM, PM, FM

**Rectangle:** 0 to 100% duty cycle AM (allows for pulse modulation)

**Arbitrary User-defined:**  $\leq$  8192 points

#### HP 8791 Model 200 Radar Simulator

The Model 200 Radar Simulator Instrument-on-a-Disk (RSID) software configures FASS to simulate advanced pulsed radar emitters.

**Frequency Hopping:** Constant, linear, scheduled, user-defined

**Intrapulse Modulation:** Coherent, noncoherent, chirp, Barker, user-defined

**Pulse Width:** 29.8 ns to 100 ms

**Rise and Fall:** 29.8 ns to 230  $\mu$ s

**Pulse Shapes:** Trapezoidal, Gaussian, exponential, user-defined

**Pulse Repetition Frequency:** 1 Hz to 625 kHz

**PRF Patterns:** Constant, burst, stagger, jitter, wobble, user-defined

**Antenna Scan Rate:** 4 to 100,000 RPM

**Main Beam Width:**  $0.1^\circ$  to  $360^\circ$

**Antenna Scan Patterns:** Circular, conical, raster, sector, user-defined

**Antenna Radiation Patterns:** Rectangular, Hamming, Hanning, Blackman, 3-term,  $\cos^n$ , programmable

#### Key Literature

HP 8791 Models 11 and 21 FASS Technical Data Sheet, p/n 5091-4425E

HP 8791 Model 7 FASS Technical Data Sheet, p/n 5091-2914E

#### Ordering Information

##### HP 8791

**Model 21** Frequency Agile Signal Simulator (E2505A)

**Model 11** Frequency Agile Signal Simulator (E2500B)

**Model 7** Frequency Agile Signal Simulator (E2506A)

**Model 100** Precision Signal Generator (E2502A Option 012)

**Model 200** Radar Simulator (E2501A Option 012)