

This literature was published years prior to the establishment of Agilent Technologies as a company independent from Hewlett-Packard and describes products or services now available through Agilent. It may also refer to products/services no longer supported by Agilent. We regret any inconvenience caused by obsolete information. For the latest information on Agilent's test and measurement products go to:

[www.agilent.com/find/products](http://www.agilent.com/find/products)

Or in the US, call Agilent Technologies at 1-800-452-4844 (8am–8pm EST)



# HP 11759D Dynamic Ghost Simulator

## Technical Data

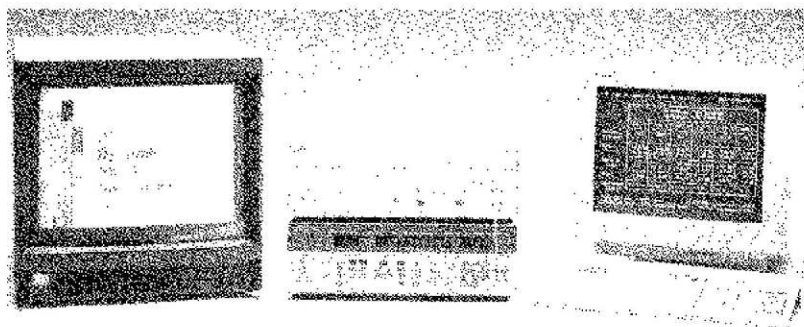

- 40 to 1000 MHz
- RF Bandwidth >6 MHz
- Doppler from  $\pm 0.01$  to  $\pm 425$  Hz
- Phase shifts to  $\pm 360^\circ$
- Delay interval to  $\pm 186$  usec with 1 ns resolution
- 12-Bit processing for low noise/distortion

### Versatile Simulation of Dynamic/Static Ghosts in TV Broadcast and CATV Signal Environments

The HP 11759D Dynamic Ghost Simulator has all the features and performance that make it the ideal solution for simulating the TV ghost conditions that occur in both 'off the air' and CATV reception conditions. The HP 11759D is specifically designed to test Ghost Cancelling Reference (GCR) Signal systems proposed for the NTSC system and bandwidth compatible digital HDTV systems proposed for terrestrial broadcast.

In addition it should be considered for ghost simulation for both Direct Broadcast Satellite (DBS) systems and systems with occupied bandwidths beyond those of the NTSC system. Systems with occupied bandwidths to 6 MHz at RF frequencies to 2700 MHz are all candidates for stress testing under the precision, repeatable ghosting conditions that can be simulated by the HP 11759D.

Testing susceptibility to both dynamic and static ghosting conditions is particularly important in the development phase of GCR systems and digital HDTV systems. Transmissions are complicated by not only a loss in signal strength on the direct path from transmitter to receiver antenna but also reflections from both stationary and moving reflectors. Multi-path images can arrive at the receiver prior to the primary signal or completely out of phase with it

### Precision Dynamic Ghost Simulations for Evaluation and Test of Ghost Cancellation and HDTV Systems of the 1990's

#### Simulates:

- Airplane flutter
- Tower sway
- Multiple fixed reflections
- Vehicle/people motion

causing extreme distortion of the displayed image in color hue and saturation and, multiple and faded images. All of these effects can be simulated by the HP 11759D with a precision and repeatability not previously available to the system designer.

Now, with the HP 11759D Dynamic Ghost Simulator's versatile and economical simulation of both static and dynamic RF ghosting (multipath) conditions, it is possible to reproduce the effects of tower sway, airplane flutter, atmospheric and geographic reflections early in the design cycle without resorting to extremely costly field trials.

**Flexibility, Precision, Performance**

The HP 11759D Dynamic Ghost Simulator contains six independent 40 MHz to 1000 MHz ghost paths. Each path can be Doppler shifted or phase shifted, delayed, and attenuated relative to the others. In addition, Log-normal fading statistics or Rayleigh fading statistics (with an adjustable correlation factor for path pairs) can be selected.

For test applications requiring in excess of 5 ghosts plus a main-path an additional 6 ghosts can be added to the system by adding a second HP 11759D to the test system for a total of 11 ghosts plus a main path.

The HP 11759D accepts an RF television signal directly at its input port (see Fig. 1) and delivers a multipath Ghost-impaired replica at its output port. A required external local

oscillator (LO) downconverts the input signal to a 6 MHz IF where precision digital signal processing can be employed. It also provides the signal necessary to return the ghost-impaired signal to its original RF frequency at the output port. This process allows the HP 11759D to remain general purpose over the full range of television broadcast frequencies and beyond.

By downconverting to a 6 MHz IF the signal processing becomes completely independent of the input RF frequency. In addition, 12-bit digital processing technology throughout the design ensures a large dynamic signal range, accuracy and, most importantly, low noise and distortion added to the input signal.

Because of the large information content contained within the bandwidth of the television

signal, it is extremely sensitive to sources of distortion such as group delay variation and amplitude flatness. Great care has been taken in the HP 11759D design to ensure that these sources of distortion are below the levels required by the television industry. Group delay variation is held to  $< \pm 15$  ns and amplitude flatness to  $< \pm 0.5$  dB over the 6 MHz specified bandwidth. Operation at bandwidths  $> 6$  MHz, although unspecified, is possible with some degradation in performance. In many cases the performance of the HP 11759D over a 7 MHz or greater bandwidth is more than adequate for the design and evaluation of existing and proposed television systems.

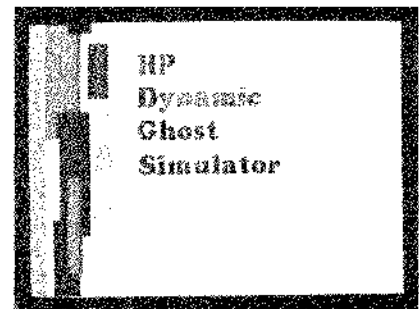
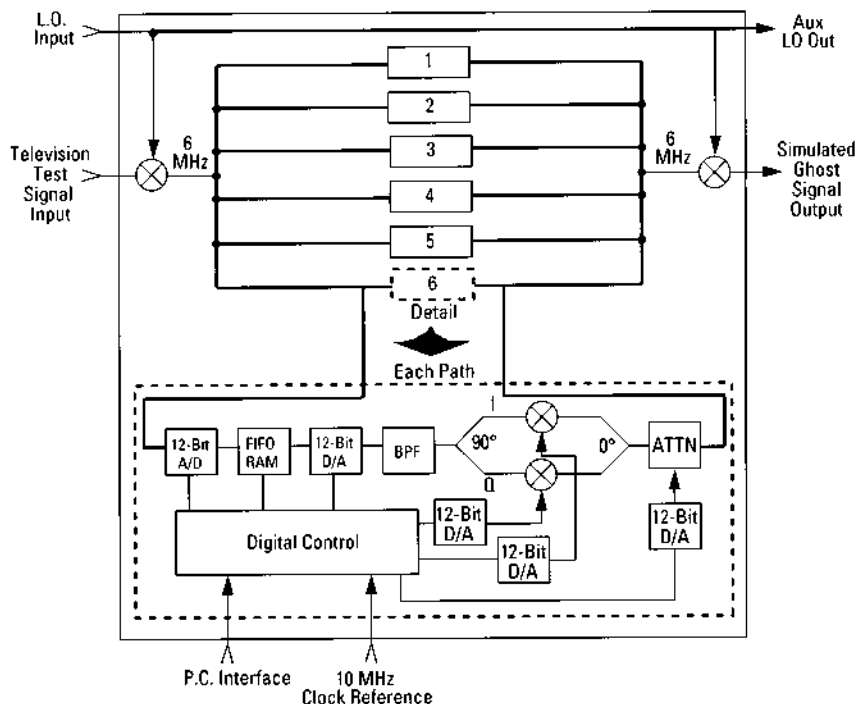

**Figure 2. Precise/repeatable TV ghost test signals.**

**Figure 1. HP 11759D Dynamic Ghost Simulator Simplified Block Diagram.**

## Friendly User Interface

Simple on-screen menus displayed on the 486DX based Personal Computer (PC) and pop-up help windows guide the user through the potentially complex task of creating RF multipath ghost signals for testing GCR system, HDTV, or CATV designs. The opening menu displays a choice of three different ghosting (multipath) simulations — Ghost Simulation Test, Dynamic Test and Travel Test.

The Ghost Simulation Test is used to create static multipath ghost conditions relative to a main path. Constant delay, power level and phase or Doppler differences between ghosts are independently selectable for up to five ghosts and a main path. The Dynamic Test allows the user to recall previously created propagation conditions which can include changing the delay, Doppler and attenuation for each path with time — conditions that are very representative of the 'real world' and never before possible with a commercially available ghost simulator. The Travel Test allows the user to simulate signal transmission from a fixed transmitter to a fixed receiver with interfering signals from up to five fixed reflectors and one moving reflector all placed on a 30 x 30 km grid.

After selecting the Ghost Simulation Test a table for entering path parameters appears on-screen. The operator can choose to enter parameters for the Spectrum type, Doppler, Delay, and Attenuation for each path, or recall either previously user-stored parameter configura-

tions (up to 10 configurations may be stored) or one of the factory stored ghost configurations. If the operator chooses to enter a particular set of parameters, then simple keystrokes, explained on-screen with pop-up windows, allow the operator to select parameters for any or all paths.

Each path may be enabled to provide either a Doppler shifted or Phase shifted ghost or, if desired, a Rayleigh faded ghost. If a Doppler spectrum is chosen then a pure Doppler from 0 to  $\pm 425$  Hz with .01 Hz resolution may be entered. A Phase Spectrum choice permits the user to adjust the relative phase of the ghost over a range of  $\pm 360$  degrees in 0.1 degree steps. In addition, for both spectrum types, the delay interval of each path can be set from 0 to 186 us and the relative attenuation of each can be adjusted from 0 to 50 dB.

The Dynamic Test is truly unique in that it is user defined and user created. The source for the dynamic multipath scenario can be actual ghosting conditions measured and recorded versus time in the field or a unique set of varying conditions

that the user desires to simulate to stress the TV receiver under unusual or anticipated conditions. Off-line, using a programming language of choice, the user writes a program to create an ASCII data file that defines the delay, Doppler and attenuation parameters at multiple points in time for each path to be controlled. Each set of parameters represents the ghosting conditions at one point in time and will be sequenced through at a rate set within the file created.

A translator utility converts the ASCII data file to a binary file used to control the HP 11759D. Thus, when the file is recalled using the Dynamic Test mode, the HP 11759D path parameters set by the file are stepped through sequentially, changing the multipath conditions dynamically with time. Sample programs written in QUICK BASIC are included with the HP 11759D software enabling the user to access subroutines for calculating Doppler, delay and level changes versus time as a reflector, such as an airplane, moves at an angle relative to the direct transmission path between a TV transmitter and receiver.

HP 11759D Dynamic Ghost Simulator Rev 3.22  
Copyright (c) Hewlett-Packard Co. 1993

GHOST SIMULATION TEST

-----MAIN MENU-----

G: Ghost Simulation Test  
D: Dynamic Test  
T: Travel Test  
C: Configuration  
H: Help (first-time installation tips)  
Q: Quit

Enter selection...

HP 11759D Dynamic Ghost Simulator Rev 3.22 GHOST SIMULATION TEST  
Test Case B

RF Frequency = 800.000000 MHz LO Frequency = 894.000000 MHz						
Path 1	Path 2	Path 3	Path 4	Path 5	Path 6	
PHASE	PHASE	PHASE	PHASE	PHASE	PHASE	PHASE
0.30 km 1.00 us	0.00 km 0.00 us	0.42 km 1.40 us	3.90 km 13.00 us	6.60 km 22.00 us	12.29 km 41.00 us	
130.0°	-60.0°	30.0°	-90.0°	0.0°	50.0°	
0.0 dB	26.0 dB	28.0 dB	20.0 dB	20.0 dB	15.0 dB	
To Path 4	To Path 5	To Path 6	(0.0)	(0.0)	(0.0)	

Spectrum:  
(file name)

Delay:

Doppler or Phase:

Atten:

Correlations:  
(Rayleigh)

[ARROW KEYS] Move [ESC] Exits Set SPECTRUM to turn path ON or OFF  
[ENTER] Sets Value [CTRL][BACKSPACE] Resets [ALT-P] Save/Recall Profiles

Loss Normal Scenario Signal Map

Move TRANSMITTER to desired location  
or enter coordinates (km)

```

> TRANSMITTER (+0.0,+2.0)
RECEIVER (+5.0,+2.0)
#1 (+0.0,+2.0) +0.0dB
#2 (+3.0,+4.0) +6.0dB
#3 (+4.0,-0.5) +5.0dB
#4 (-2.0,+0.0) +10.0dB
#5 (MOVING) +5.0dB

```

MOVING REFLECTOR moves from (-0,+0) to (+15.0,+0)

[TAB] exit and save changes; [ESC] exit without saving changes  
[ENTER] enter atten, mov to next signal; [BACKSPACE] move to previous signal  
[ID] delete signal; [I] insert new signal; [SPACE BAR] move to origin  
[ARROW KEYS] move signal; [+][=][I][O][P] enter signal location from keyboard

The Travel Test is a novel but powerful multipath ghosting simulation. The user first selects whether a moving reflector or receiver is desired. Then, a 30 x 30 km grid is displayed on the PC and, using simple keystrokes, the transmitter, receiver and omnidirectional reflectors (one for each path in the system configuration) with individually chosen loss factors are placed on the grid. Next, reflector (or receiver) velocity, RF frequency, and the loss exponent for the medium are selected. A keystroke then starts a reflector (or receiver) moving from the origin to +15 km along the X-axis. At each new position

a new multipath profile is calculated and output. The Doppler and level are corrected for the changed angle of arrival and path length and a log-normal amplitude distribution if previously chosen is applied.

The resulting multipath signal is unique to the choice of receiver and transmitter positions and can be used to approximate actual ghost conditions encountered in a particular geographic area.

### Economical and Simple to Configure

The HP 11759D Dynamic Ghost Simulator consists of the applica-

tions software and the RF processing hardware. To complete the RF ghost simulation system two other user-supplied components are necessary — a PC acting as a front panel/controller for the HP 11759D and an RF local oscillator used to determine the RF operating frequency and to supply a 10 MHz timebase.

This separation of functions permits an acquisition cost significantly less than one normally expects for a product of this complexity and capability. Significant savings are achieved by not burdening the HP 11759D with the cost of built-in local oscillator and control functions. Many users will already have an appropriate PC and local oscillator in their equipment inventory.

The PC must be at least 486DX based running at 33 MHz or faster, with a numerical co-processor, 4MB of add-on memory, and MS-DOS 5.0 or higher installed. A hard disk drive, floppy disk drive, parallel interface and VGA monitor are also required (an additional HP-IB interface is required if remote control is to be implemented). The local oscillator (synthesized) must cover the RF frequency range of interest, offset by 6.0 MHz, with at least +10 dBm output level and have a 10 MHz timebase output of 0 dBm.

Remote control of the HP 11759D Dynamic Ghost Simulator software is also easily accomplished with readily available equipment. The PC which is used to control the HP 11759D is itself controlled through an HP-IB interface card installed in the PC. Most menus can be accessed and controlled from a remote terminal or remote computer.

## Specifications

Specifications describe the instrument's warranted performance over the 15 to 35°C temperature range. Supplemental characteristics (*in italics*) are intended to provide information useful in applying the instrument by giving typical but not warranted performance parameters. These are denoted as "typical" or "nominal."

NOTE: All Specifications measured under the following conditions:

RF Input Frequency = 50/200/900 MHz  
RF Input Level = -10 dBm (+97 dB $\mu$ V)  
nominal (0.1 dB <power overrange)  
LO Input Frequency = RF Input Frequency  
less 6 MHz  
LO Input Level = +10 dBm (+117 dB $\mu$ V)  
Controller: HP Vectra 486/33T, 4 MB  
Extended Memory, and MS-DOS Version 5.00.

### RF Channel Specifications

**Number of RF Channels:** 1 of 6 paths

**Impedance (RFin, RFout, LOin):** 50  
*nominal*

**RF Input level (+20 dBm maximum —  
damage level):** -10 dBm (+97 dB $\mu$ V) *nominal*  
(Automatic sensor indicates peak power in excess  
of optimum)

**RF Frequency Range:** 40 MHz to 1000 MHz  
(useable 40 to 2700 MHz)

**RF Bandwidth (1dB):** >6 MHz *typically*

**Group Delay variation over 6 MHz band-  
width:** < $\pm 15$  nsec *typically*

**Path Insertion Loss (0 dB attenuation, band  
center):** *Typically 24 dB  $\pm 3$  dB, 40-1000 MHz*

**Insertion Loss variation (path to path):**  
*< $\pm 0.1$  dB typical at band center.*

**Path Insertion Delay (RFin to RFout, 0 ns  
delay):** *<600 ns typical*

**Path to Path Insertion Delay variation:**  
*< $\pm 10$  ns typical at band center.*

**LO Input Frequency Range:** RF Input  
Frequency  $\pm 6$  MHz

**LO Input level:** +10 dBm to +13 dBm  
(+117 dB $\mu$ V to +120 dB $\mu$ V)

**LO Feedthrough on RFout:** *typically*  
*<-20 dBm (+87 dB $\mu$ V)*

**Image Feedthrough on RFout:** = RFout level

**Path ON/OFF Ratio (RFin = 900 MHz):**  
*>65 dB typical*

**Path RFout S/N Ratio (RFin 900 MHz,  
6 MHz BW):** *-54 dBc typical*

**RFout Spurious levels:** *In-band ( $\pm < 3$  MHz);*  
*-55 dBc typical in Ghost Simulation Test and low*  
*delay resolution,*  
*-50 dBc typical in Travel Test and Ghost Simula-*  
*tion Test with high delay resolution*

The following characteristics apply only to RF signals modulated with NTSC formats centered in the 6 MHz signal processing bandwidth with the overrange indicator OFF by 0.1 dB.

- 1. Chrominance-to-luminance delay inequality:** *<10 ns typical*
- 2. Chrominance-to-luminance gain inequality:** *<4% typical*
- 3. Differential Phase distortion:** *<1 degree typical*
- 4. Differential Gain distortion:** *<1 % typical*

### Ghost Simulation Specifications

Number of independent ghosts (paths): 6 including main signal. Independent Delay, Doppler(or Phase) and level available on each path.

#### Path Attenuation:

**Range:** 0 to 50 dB

**Resolution:** 0.1 dB

**Accuracy:**  *$\pm 0.3$  dB typical 0-30dB,  $\pm 1.0$  dB*  
*typical >30-40 dB,  $\pm 2.0$  dB typical >40-50 dB*

#### Relative Delay Interval between paths:

**Range:** 0 to  $\pm 186.2$   $\mu$ s in Ghost Simulation  
Test mode, with a maximum delay difference  
between paths of 186.2  $\mu$ s.

Note: Delays to  $\pm 1.49$  ms are available by  
special order.

0 to 39.9  $\mu$ s in Travel Test mode

**Resolution:** 1.0 ns

**Accuracy:** *typically  $\pm 25$  ns + Insertion Delay*  
*variation*

**Simulated Doppler (DOPPLER SPECTRUM MODE):**

**Range:** 0 to ±425 Hz  
**Resolution:** 0.01 Hz

**Relative Phase between Paths (PHASE SPECTRUM MODE):**

**Range:** 0 to ±360 degrees  
**Resolution:** 0.1 degrees

**Rayleigh Amplitude Distribution:** available on all paths in RAYLEIGH SPECTRUM MODE for Doppler to 425 Hz. Correlation Coefficient between paths 1/4, 2/5, 3/6 is adjustable from 0-1 in 0.1 steps. Note: if two HP 11759D's are configured in the system then 6x6 correlation may be selected.

**Remote Control**

The Dynamic Ghost Simulator software is remotely controllable through a HP-IB Interface card installed in the Personal Computer controlling the HP 11759D. Most menus can be accessed and controlled from a remote terminal or remote computer.

**General**

**Operating Temperature Range:** 0 to +55°C

Note: Specifications warranted +15 to +35°C

**Storage Temperature:** -55 to +75°C

**Humidity (Operating):** up to 95% relative humidity to +40°C

**EMC:** Conducted and radiated interference is within the requirements of EN55011, Group 1, Class A/CISPR Pub. 11 (1990). Meets the requirements of EN50082-1/IEC 801, -2, -3, -4 Acoustic Noise Emissions/Geraeuschemission:

	LpA: Per EN 27779
<i>Operator Position: am Arbeitsplatz:</i>	<i>44 dB (typical)</i>
<i>Bystander Position: Nachbararbeitsplatz</i>	<i>36 dB (typical)</i>

**Power:** 90-132/190-264 V; 48-66 Hz; 325 VA maximum

**Weight:** Net: 13.6 kg (30 lb); Shipping: 19 kg (42 lb)

**Dimensions:** 620 mm D x 425 mm W x 146 mm H (24.4" x 16.8" x 5.7")

**Rear Panel Connectors:**

LO Output (Type N(f)); +10 dBm nominal  
Timebase Input (BNC(f)); 10 MHz; 0 dBm nominal

System Interface; 36-pin Female Centronics

**Supplied with each HP 11759D:** Power cord, Operating and Service Manual, System Software supplied on 3 1/2" 720 KB capacity floppy disk media and 5 1/4" 1.2 MB capacity floppy disk media.

**System Controller Minimum Requirements**

33 MHz PC compatible, 486DX with 1 MB RAM and Math Coprocessor

4 MB Add-on extended memory

30 MB free Hard Disk space, and 3 1/2" Floppy Disk drive

Parallel Printer Interface

Graphics Adapter and VGA monitor

MS-DOS Version 5.0 or higher

**Minimum System Configuration**

1 each HP 11759D Dynamic Ghost Simulator

1 each System controller (Personal Computer as described above)

1 each Local Oscillator with a 10 MHz timebase output

1 each 25-pin Male Centronics to 36-pin Male Centronics cable-recommended HP 24542D, 2.0 m (6.6 ft.)

## Recommended Accessories

### PC Controller

<b>HP Vectra 486/33U</b>	P/N HP D2274B
<b>Model 120</b>	
plus: 14" VGA Color Display	P/N HP D1194A
4-MByte Memory upgrade	P/N HP D2381A (2 ea.)
Parallel interface cable	P/N HP 24542D (2.0 m)
Optional HP-IB Interface	P/N HP 82335B
Optional Serial/Parallel Interface for Second HP 11759D	P/N HP 24540B

### Local Oscillator

HP 8656B Signal Generator 0.1-990 MHz or  
HP 8657A Signal Generator 0.1-1040 MHz or  
HP 8657B Signal Generator 0.1-2060 MHz or  
HP 8644A Signal Generator 0.25-1030 MHz

Please consult your HP sales representative for information on additional PC controllers and Local Oscillators available from Hewlett-Packard Company.

**Power Divider/Combiner** (useful when two HP 11759D's are used for up to 12 Ghost Simulation)

HP 11636A Power Divider/Combiner.

## Ordering Information

HP 11759D Dynamic Ghost Simulator Options:

002 Rear panel only RF connectors  
907 Front panel handle kit  
908 Rack mount flange kit  
909 Rack mount flange kit with handles  
910 Extra operating and service manual  
W30 Two additional years of Return-to-HP service

## Ghost Simulation Features (Menus)

1. Ghost Simulation Test — Allows independently selectable relative delay, Doppler (or Phase) and attenuation for up to 11 Ghosts plus a main signal (12 paths total for a two HP 11759D configuration). Delay may be entered as path distance (km) or time ( $\mu$ s), either positive or negative, and Doppler may be entered as velocity (km/h) or frequency (Hz) also either positive or negative. If velocity is entered, Doppler is calculated using the RF channel frequency entered (default is 900 MHz). Up to 10 user defined Ghost Simulation Test scenarios may be saved for future recall.

2. Travel Test — Allows 1 to 6 (12) path Ghost simulation with either a moving reflector or a moving receiver. Log-normal fading statistics may be added to the signals (Ghosts) if the user chooses. The user positions a Transmitter, a receiver (if a moving reflector scenario is chosen) and 1 to 5 (11 with two HP 11759D's) fixed omnidirectional reflectors on a 30 km x 30 km grid. The moving reflector (or receiver) travels from the origin to +15 km on the X-axis at a velocity selected by the user. RF frequency, path loss in dB/decade, reflector loss and the standard deviation for the log-normal fading are selectable. Any number of reflector, transmitter and receiver mappings may be saved under unique file names and replayed in real time using the available recall feature.

3. Dynamic Test — User defined dynamic parameter modification. Utilities provided enable dynamic control of delay, Doppler, relative phase and attenuation for up to 12 independent paths at rates up to 100 complete 12 path modifications per second. Transmitter tower sway and airplane flutter are two examples of dynamic ghost parameter modifications that can be simulated using this software utility. Each dynamic scenario created can be saved to the PC hard disk memory under a unique file name and is available for replay at any time.

For more information, call your local HP sales office listed in the telephone directory white pages or an HP regional office listed below for the location of your nearest sales office.

**United States:**

Hewlett-Packard Company  
4 Choke Cherry Road  
Rockville, MD 20850  
(301) 670-4300

Hewlett-Packard Company  
5201 Tollview Drive  
Rolling Meadows, IL 60008  
(708) 255-9800

Hewlett-Packard Company  
1421 S. Manhattan Ave.  
Fullerton, CA 92631  
(714) 999-6700

Hewlett-Packard Company  
2015 South Park Place  
Atlanta, GA 30339  
(404) 955-1500

**Canada:**

Hewlett-Packard Ltd.  
6877 Goreway Drive  
Mississauga, Ontario L4V1M8  
(416) 678 9430

**Japan:**

Yokogawa-Hewlett-Packard Ltd.  
91 Takakura-cho  
Hachioji  
Tokyo 192, Japan  
0426-42-1231

**Latin America:**

Hewlett-Packard  
Latin American Region Headquarters  
5200 Blue Lagoon Drive, 9th floor  
Miami, Florida 33126  
U.S.A.  
(305) 267-4245/4220

**Australia/New Zealand:**

Hewlett-Packard Australia Ltd.  
31-41 Joseph Street  
Blackburn, Victoria 3130  
Melbourne, Australia  
(03) 895-2895

**Europe**

Hewlett-Packard S.A.  
European Marketing Centre  
P.O. Box 999  
1180 AZ Amstelveen  
The Netherlands  
(31) 20 547 66698

**Far East:**

Hewlett-Packard Pacific Ltd.  
22-30/F Peregrine Tower  
Lippo Centre  
89 Queensway, Central  
Hong Kong  
(852) 848 7070

**Data Subject to Change  
Printed in U.S.A. March 1993**

**Hewlett-Packard Company  
Copyright © 1993  
5091-6793 E**