

# The HP MultiProbe System

## Technical Specifications

**For use with the  
HP 16500B Logic  
Analysis System**

The HP MultiProbe System consists of the following components:

- HP E5320A  
9-to-2 analog probe pod
- HP E5321A  
240-to-2 analog probe pod and  
240-pin QFP adapter
- HP E5322A  
208-to-2 analog probe pod and  
160-pin QFP or 208-pin QFP  
adapter
- HP 16535A  
MultiProbe control module

Specifications and characteristics apply only within an ambient temperature range of  $\pm 10$  °C from the temperature at which self-calibration was performed.

**The following specifications and characteristics apply when using an HP MultiProbe pod and an HP 16535A MultiProbe control module.**

Specifications	HP E5320A	HP E5321A HP E5322A
Attenuation (Nominal) (from any input of the MultiProbe pod to the output of the HP 16535A MultiProbe control module) <sup>[1]</sup>	50:1 or 25:1	50:1 or 25:1
dc offset <sup>[2]</sup>	$\pm 1$ mV	$\pm 1$ mV
Bandwidth	> 1 GHz	> 750 MHz
Characteristics	HP E5320A	HP E5321A HP E5322A
Input resistance	10 K $\Omega$ $\pm 2\%$	20 K $\Omega$ (Nominal)
Input capacitance (typ)	1 pF	3.3 pF <sup>[3]</sup>
Mutual capacitance (typ) (adjacent pins)	N/A	0.45 pF
Dynamic range (referenced to input)		
Attenuation = 50:1	- 6V to + 13V	- 4V to + 10V
Attenuation = 25:1	- 3V to + 10V	- 3V to + 9V
Gain Compression	< 2%	< 4%
dc offset drift	300 $\mu$ V per °C	
Propagation delay (nominal) from an input of the MultiProbe pod to the output of the HP 16535A MultiProbe control module	10.5 ns	10.5 ns
Rise time (calculated from bandwidth)	< 350 ps	< 467 ps
Overshoot (for a step with a rise time > 500 ps)	< 5%	< 5%
Coupling (for a step with a rise time > 1 ns) (internal to probe)	< 4%	< 4%
ESD Tolerance	$\pm 8$ kV (150 pF, 330 $\Omega$ )	<b>Requires ESD precautions</b>
Maximum input voltage (dc + peak ac)	$\pm 40$ V	$\pm 20$ V
Operating temperature	0 to 55 °C	0 to 55 °C

**Notes:**

<sup>[1]</sup>The actual probe attenuation is indicated in the user interface. The indicated probe attenuation is correct within  $\pm 2\%$  (specification).

<sup>[2]</sup>At the temperature at which the self-calibration was performed.

<sup>[3]</sup>The input capacitance (3.3 pF) is the capacitance to ground (2.4 pF) plus the mutual capacitance between each adjacent pin (0.45 pF)  $\times 2$ .

The following typical performance characteristics apply when using an HP MultiProbe pod, an HP 16535A MultiProbe control module, and an HP 16534A oscilloscope.

Characteristics	HP E5320A	HP E5321A HP E5322A
dc voltage measurement accuracy	±3% of full scale	±3% of full scale
dc offset accuracy	±[1% of offset + 2% of full scale + (1 mV + 300 μV/°C) × probe attenuation factor]	
Bandwidth	> 500 MHz	> 500 MHz
Rise time (calculated from bandwidth)	< 700 ps	< 700 ps
<b>Differential time interval measurement accuracy</b>		
For two inputs on the same pod	< 200 ps	< 250 ps
For two inputs on different pods	< 300 ps	< 300 ps

The following characteristics apply when using an HP MultiProbe pod and an HP 16535A MultiProbe control module with other oscilloscopes.

Characteristics	HP E5320A	HP E5321A HP E5322A
<b>Bandwidth (typical)</b>		
HP 54121T, HP 54750A	1 GHz 1 GHz	750 MHz 750 MHz
HP 54710A, D HP 54720A, D		
<b>with plug-in:</b>		
HP 54711A	1 GHz	750 MHz
HP 54712A	800 MHz	600 MHz
HP 54721A	800 MHz	600 MHz
HP 54713B	500 MHz	500 MHz
HP 54714A	500 MHz	500 MHz
HP 54715A	500 MHz	500 MHz
HP 16532A, HP 16533A	250 MHz 250 MHz	250 MHz 250 MHz
<b>Differential time interval measurement accuracy [4]</b>		
<b>Signals on same HP MultiProbe pod</b>		
with correction factors	± 200 ps	± 250 ps
without correction factors	± 300 ps	± 500 ps
<b>Signals on different HP MultiProbe pods</b>		
with correction factors	± 300 ps	± 300 ps
without correction factors	± 800 ps	± 800 ps

[4] Skew correction factors are provided on the HP MultiProbe control module user interface that can be used to correct differential time interval measurements on other oscilloscopes.

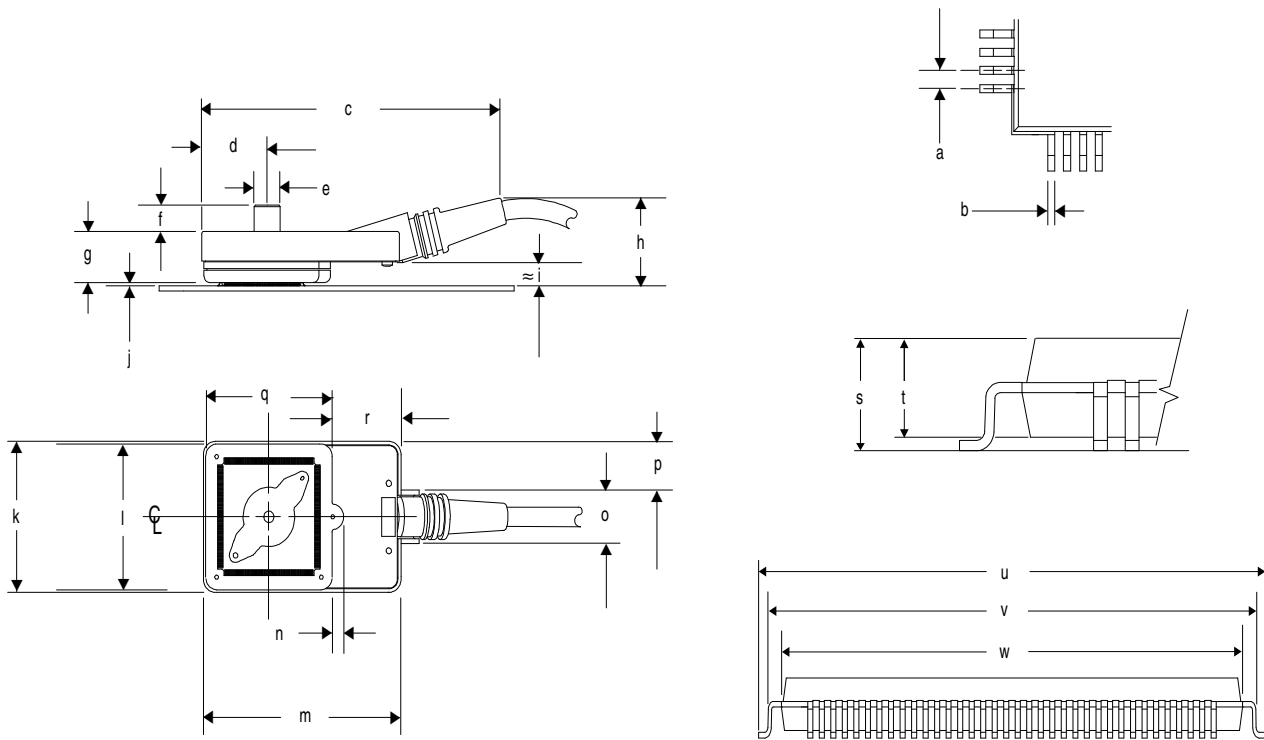

Dimension	160-pin IC HP E5322A 28 mm square		208-pin IC HP E5322A 28 mm square		240-pin IC HP E5321A 32 mm square	
	inches	millimeters	inches	millimeters	inches	millimeters
a	0.0256	0.65	0.0197	0.50	0.0197	0.50
b	0.087 to 0.0015	0.22 to 0.38	0.0067 to 0.0106	0.17 to 0.27	0.0067 to 0.0106	0.17 to 0.27
c	3.957	100.5	3.957	100.5	4.114	104.5
d	0.823	20.9	0.823	20.9	0.902	22.9
e	0.354	9.0	0.354	9.0	0.354	9.0
f	0.311	7.9	0.311	7.9	0.311	7.9
g	0.622	15.8	0.622	15.8	0.622	15.8
h	1.047	26.6	1.047	26.6	1.047	26.6
i	≈0.295	≈7.5	≈0.295	≈7.5	≈0.295	≈7.5
j	(minimum)	0.8 mm (0.032 in)				
k	1.646	41.8	1.646	41.8	1.803	45.8
l	1.583	40.2	1.583	40.2	1.740	44.2
m	2.567	65.2	2.567	65.2	2.724	69.2
n	0.168	4.0	0.168	4.0	0.168	4.0
o	0.638	16.2	0.638	16.2	0.638	16.2
p	0.504	12.8	0.504	12.8	0.583	14.8
q	1.583	40.21	1.583	40.21	1.740	44.2
r	0.952	24.19	0.952	24.19	0.952	24.19
s	0.136 min 0.161 max	3.45 min 4.10 max	0.136 min 0.161 max	3.45 min 4.10 max	0.136 min 0.161 max	3.45 min 4.10 max
t	0.126 min 0.146 max	3.20 min 3.70 max	0.126 min 0.142 max	3.20 min 3.60 max	0.126 min 0.142 max	3.20 min 3.60 max
u	1.27 max	32.15 max	1.205 ±0.008	30.6 ±0.2	1.362 ±0.008	34.60 ±0.2
v	1.154 min	29.32 min	1.136 min	28.85 min	1.293 min	32.85 min
w	1.106 max	28.10 max	1.110 max	28.20 max	1.268 max	32.20 max

**Figure 1. IC pin and high-density pod dimensions**

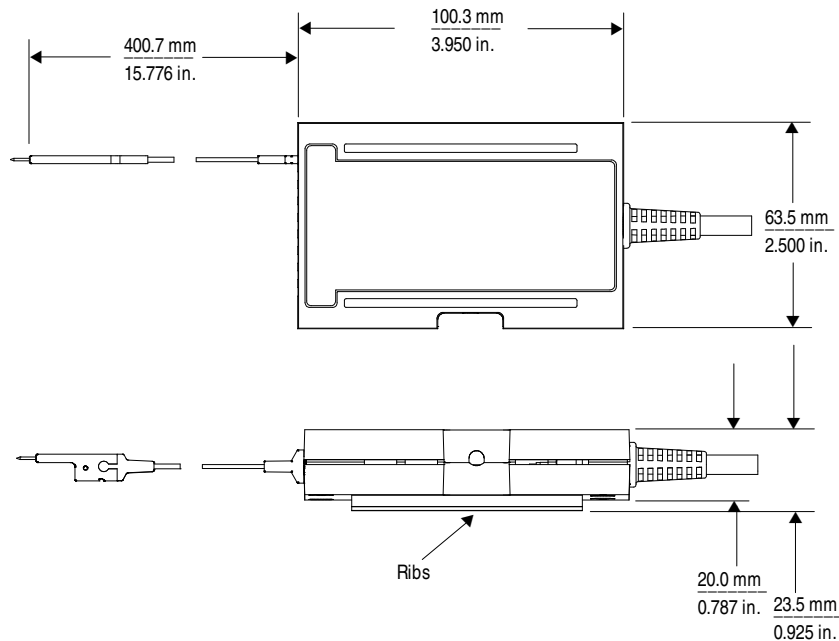

**Figure 2.**  
**The HP E5320A**  
**general-purpose**  
**pod dimensions**

**For more information on Hewlett-Packard Test & Measurement products, applications or services please call your local Hewlett-Packard sales offices. A current listing is available via Web through Access HP at <http://www.hp.com>. If you do not have access to the internet, please contact one of the HP centers listed below and they will direct you to your nearest HP representative.**

**United States:**

Hewlett-Packard Company  
 Test and Measurement Organization  
 5301 Stevens Creek Blvd.  
 Bldg. 51L-SC  
 Santa Clara, CA 95052-8059  
 1 800 452 4844

**Canada:**

Hewlett-Packard Canada Ltd.  
 5150 Spectrum Way  
 Mississauga, Ontario  
 L4W 5G1  
 (905) 206 4725

**Europe:**

Hewlett-Packard  
 European Marketing Centre  
 P.O. Box 999  
 1180 AZ Amstelveen  
 The Netherlands

**Japan:**

Hewlett-Packard Japan Ltd.  
 Measurement Assistance Center  
 9-1, Takakura-Cho, Hachioji-Shi,  
 Tokyo 192, Japan  
 Tel: (81-426) 56-7832  
 Fax: (81-426) 56-7840

**Latin America:**

Hewlett-Packard  
 Latin American Region Headquarters  
 5200 Blue Lagoon Drive  
 9th Floor  
 Miami, Florida 33126  
 U.S.A.  
 (305) 267 4245/4220

**Australia/New Zealand:**

Hewlett-Packard Australia Ltd.  
 31-41 Joseph Street  
 Blackburn, Victoria 3130  
 Australia  
 1- 800 629 485

**Asia Pacific:**

Hewlett-Packard Asia Pacific Ltd  
 17-21/F Shell Tower, Time Square,  
 1 Matheson Street, Causeway Bay,  
 Hong Kong  
 Fax: (852) 2506 9285

**Technical information in this document is subject to change without notice.**

**Printed in U.S.A.**  
**5964-0237E**

**8/96**

**© Hewlett Packard Company 1996**