

---

# HP 8711B and HP 8713B RF Economy Scalar Network Analyzers

## Technical Specifications

HP 8711B, 300 kHz to 1.3 GHz  
HP 8713B, 300 kHz to 3.0 GHz

---

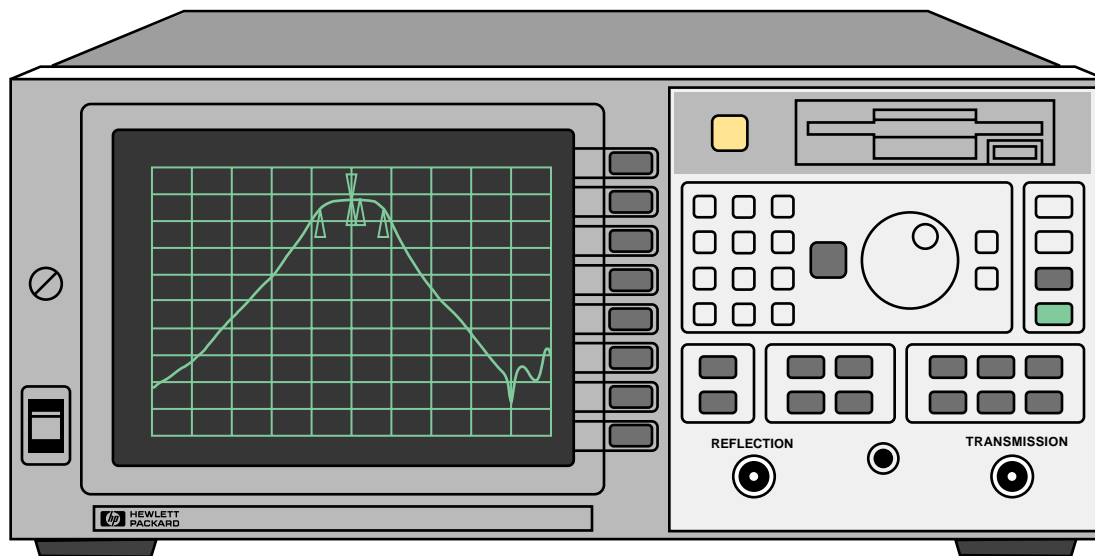

## Specifications

### Measurement Ports

	HP 8712B	HP 8714B
	50 and 75 ohm	
Directivity	40 dB	40 dB
Source match (reflection)	20 dB	20 dB
Source match (transmission)	14 dB typical <sup>1</sup>	23 dB typical at <1.3 GHz, 20 dB typical at >1.3 GHz
Load match	18 dB typical	20 dB typical at <1.3 GHz, 18 dB typical at >1.3 GHz
Reflection Tracking	0 ±0.4 dB typical	0 ±0.2 dB typical

This table shows the residual HP 8712B and 8714B system specifications. These characteristics apply at an environmental temperature of 25° ±5° C, with less than 1° C deviation from the calibration temperature. Directivity and source match specifications apply after calibration.

### Source

#### Frequency

Range	300 kHz to 1.3 GHz (HP 8712B) 300 kHz to 3.0 GHz (HP 8714B)
Resolution	1 Hz
Stability	±5 ppm 0° C to 55° C (typical)
Accuracy	1) ±5 ppm at 25° C ±5° C 2) <1 Hz at 10% change in line voltage

#### Harmonics

<-20 dBc, <1 MHz
<-30 dBc, >1 MHz for HP 8712B,
<-30 dBc for HP 8714B

#### Output Power

Resolution	0.01 dB
Level accuracy	±1.0 dB ±1.5 dB Option 1EC1 ±2.0 dB Option 1E1 ±3.0 dB Option 1EC1 and 1E1

### Maximum and minimum power

Options	HP 8712B				HP 8714B	
	≤1.0 GHz		>1.0 GHz		minimum power	maximum power
	minimum power	maximum power	minimum power	maximum power		
No options	0 dBm	16	0	13	-5	10
1E1	-60	15	-60	12	-60	9
1EC1	-3	13	-3	10	-8	7
1DA/DB	-2	14	-2	11	-9	6
1E1 and 1EC1	-60	12	-60	9	-60	6
1E1 and 1DA	-60	13	-60	10	-60	5
1EC1 and 1DB	-5	11	-5	8	-12	3
1EC1, 1E1, and 1DB	-60	10	-60	7	-60	2

1. All power specifications with Option 1EC (75 ohms) are typical above 2.0 GHz.

## Receiver

Frequency range	HP 8712B	HP 8714B
Narrowband	300 kHz to 1.3 GHz	300 kHz to 3.0 GHz
Broadband	0.10 to 1.3 GHz	0.10 to 3.0 GHz

### Dynamic range<sup>2</sup>

Narrowband 50 ohm	>100 dB, $\geq 5$ MHz (+10 to -90 dBm) >60 dB, <5 MHz (+10 to -50 dBm)	>100 dB (+10 to -90 dBm)
Narrowband 75 ohm	>97 dB, >5 MHz (+10 to -87 dBm) >57 dB, <5 MHz (+10 to -47 dBm)	>97 dB (+10 to -87 dBm)
Broadband 50 ohm	> 66 dB (+16 to -50 dBm)	>66 dB (+16 to -50 dBm)
75 ohm	> 63 dB (+16 to -47 dBm)	>63 dB (+16 to -47 dBm)

<b>Damage level</b>	+23 dBm, $\pm 25$ VDC	+23 dBm, $\pm 25$ VDC
---------------------	--------------------------	--------------------------

<b>Maximum input</b>		
Narrowband (0.5 dB compression)	+10 dBm	+10 dBm
Broadband (0.55 dB compression)	+16 dBm	+16 dBm

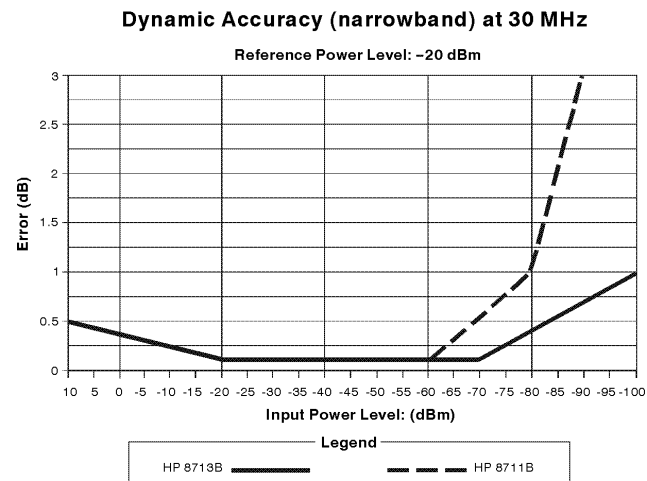

- Receiver dynamic range is calculated as the difference between maximum receiver input level and receiver's noise floor. System dynamic range applies to transmission measurements only, since reflection measurements are limited by directivity. Noise floor is specified as the mean trace noise at specified CW frequencies. A signal at this level would have a signal to noise ratio of 3 dB. Noise floor is measured with test ports terminated in loads, response and isolation calibration, 15 Hz IF bandwidth, 10 dB source power and no averaging.

## Supplemental data

### Source signal purity

	HP 8711B	HP 8713B
<b>Nonharmonic spurious</b>		
≥50 kHz from carrier	<-20 dBc, < 1 MHz <-30 dBc, ≥ 1 MHz	<-30 dBc
<50 kHz from carrier	<-25 dB	<-25 dBc
<b>Phase noise</b> (10 kHz offset)	-70 dBc/Hz	-67 dBc/Hz
<b>Residual AM</b> (in 100 kHz bandwidth)	<-50 dBc	<-50 dBc
<b>Residual FM</b> 30 Hz to 15 kHz	<1.5 kHz peak	<1.5 kHz peak

### Absolute power accuracy (typical, broadband)

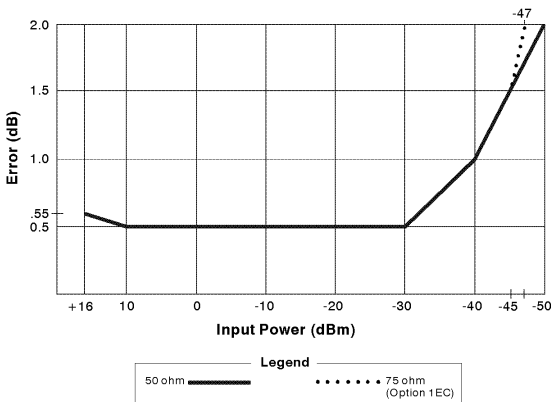

Total power accuracy = absolute power accuracy  $\pm 0.5$  dB for HP 8711B,  $\pm 1.0$  dB for HP 8713B.

### Display characteristics

<b>Display resolution</b>	0.01 dB/division
<b>Marker reference level</b>	range: $\pm 500$ dB resolution: 0.01 dB

### Typical measurement uncertainty for HP 8713B at 1.3 GHz

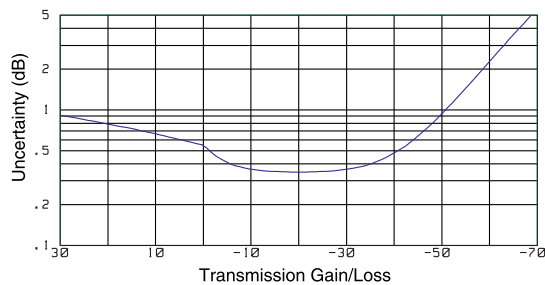

Transmission magnitude uncertainty

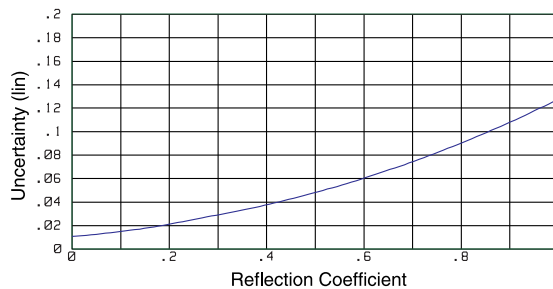

Reflection magnitude uncertainty

These graphs show the measurement uncertainty for the HP 8713B. The assumptions made to generate these curves were: For transmission uncertainty,  $S_{11} = S_{22} = 0.0$ ; and for the reflection uncertainty,  $S_{21} = S_{12} = 0.0$ . Reflection tracking = 0.2 dB, transmission tracking = 0.2704 dB (computed from match terms), and trace noise = 0.02 dB. Power = 0 dBm for reflection measurements, and -20 dBm for transmission measurements.

## Characteristics

---

### Measurement

#### Number of display channels

Two display channels are available.

#### Measurements

- Narrowband: reflection (A/R), transmission (B/R), A, B, R,
- Broadband: X, Y, Y/X, X/Y, Y/R\*, power (B\*, R\*), conversion loss (B\*/R\*)

#### Formats

Rectilinear: log/linear magnitude, SWR, real and imaginary, and dBv, dBmv and dBuv (75 ohm only)

#### Data markers

Each display channel has eight markers. Markers are coupled between channels. Any one of eight markers can be the reference marker for delta marker operation. Annotation for up to four markers can be displayed at one time.

#### Marker functions

Markers can be used for various functions: marker search, mkr to max, mkr to min, mkr → target, mkr bandwidth and notch. Also with user-defined target values, mkr → center, mkr → reference, mkr → electrical delay are available. The tracking function enables continuous update of marker search values on each sweep.

For testing cable TV broadband amplifiers, the slope and flatness functions enable rapid tuning. Marker statistics enable measurement of the mean, peak-to-peak and standard deviation of the data between two markers.

### Storage

#### Internal memory

400 Kbytes of nonvolatile storage are available to store up to 100 instrument states via the save/recall menu.

Instrument states include all control settings, active limit lines, memory trace data, active calibration coefficients, and custom display titles.

#### Disk drives

Data, instrument states (including calibration data), and HP Instrument BASIC (IBASIC) programs can also be stored on disk, using the built-in disk drive or an external disk drive with command subset CS/80. Data can be stored to disk in MS-DOS format or Hewlett-Packard's standard LIF format. Data can be stored in binary, PCX, HP-GL or ASCII formats.

### Data hardcopy

#### Data plotting

Hard copy plots are automatically produced with HP-GL compatible digital plotters such as the HP 7475A and compatible graphics printers such as the HP DeskJet or LaserJet (in single color or multi-color format). The analyzer provides Centronics, RS-232C, and HP-IB interfaces.

#### Data listings

Printouts of instrument data are directly produced with a printer such as the HP DeskJet 540 or 560C or PaintJet 3630A (color).

#### CRT formats

Single-channel, dual-channel overlay (both traces on one graticule) or dual-channel split (each trace on separate graticules).

#### Trace functions

Display current measurement data, memory data or current measurement with memory data simultaneously. Vector division of current linear measurement values and memory data.

#### Display annotations

Start/stop, center/span or CW frequency, scale/division, reference level, marker data, soft key functions, warning and caution messages, trace, titles, clock and pass/fail indication.

#### Limit lines

Create test limit lines that appear on the display for pass/fail testing. Limits may be any combination of lines or discrete points. Limit test TTL output available for external control or indication. Limit lines are only available in rectilinear formats.

### Remote programming

#### Interface

HP-IB interface operates to IEEE 488.2 and SCPI standard interface commands.

#### Pass control

Allows the analyzer to request control of the HP-IB (when an active controller is present) output to a plotter or printer.

#### System controller

Lets the analyzer become the controller on the HP-IB bus to directly control a plotter or a printer.

#### Data transfer formats

- Binary (internal 48-bit floating point complex format)
- ASCII
- 32- or 64-bit IEEE 754 floating point format
- Mass memory transfer commands allow file transfer between external controller and analyzer.

## Characteristics

### Determining optimal sweep speed and dynamic range

Dynamic range, sweep time and IF Bandwidth are interdependent quantities. When sweep time is reduced, dynamic range tends to decrease. The application requirement determines the appropriate tradeoff between sweep speed and dynamic range. The following charts will help in making these tradeoffs. All data determined from preset conditions, except as noted.

#### HP 8713B dynamic range vs IF BW (typical)

IF bandwidth	Narrowband dynamic range
Wide (6500 Hz)	70 dB typical
Medium (3700Hz)	90 dB typical
Narrow (250 Hz)	105 dB typical
Fine (15 Hz)	110 dB typical

#### Measurement sweep times

	HP 8711B		HP 8713B	
	fwd	cycle	fwd	cycle
Medium IF BW	132	159	182	223
Wide IF BW	64	72	118	159
CF=177 MHz, Span=200 MHz	51	59	68	87

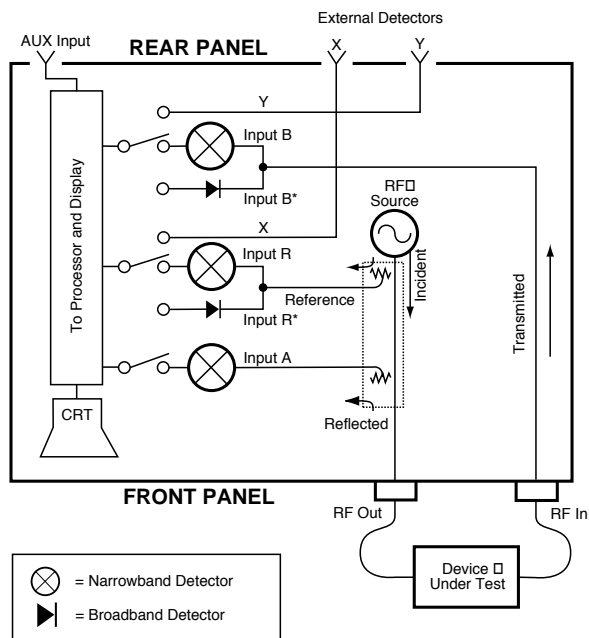

HP 8711B/8713B block diagram

### Determining automated test configuration

The following charts can help you decide on a system configuration for an automated test. For example, you may need to determine whether transferring data to an external computer or using the built-in IBASIC capabilities.

#### Speed of common IBASIC operations (in microseconds)

Operation	Platform	
	HP 871X IBASIC	80486DX 33 MHz
int16 ADD	182	35
int16 SUB	200	36
int16 MUL	219	39
int16 DIV	860	124
float64 ADD	366	94
float64 SUB	346	93
float64 MUL	384	92
float64 DIV	502	95

#### Trace transfer time (in milliseconds)

Format	Number of points			
	51	201	401	1601
Corrected (Int, 16)	26	31	39	85
Corrected (Real, 64)	32	65	97	330
Corrected (ASCII)	105	364	713	3000
Formatted (Real, 64)	38	59	98	335
Formatted (ASCII)	60	199	390	1510

#### Entering HP 8711 data into a HP BASIC workstation (HP 735/125)

Format	Number of points			
	51	201	401	1601
Corrected (Real, 64)	32	65	97	330
Formatted (Real, 64)	38	59	98	335

#### Entering data from IBASIC

Format	Number of points			
	51	201	401	1601
Corrected (Int, 16)	28	30	38	102
Corrected (Real, 32)	38	100	182	675
Corrected (Real, 64)	36	90	161	593
Corrected (ASCII)	130	470	923	3600
Formatted (Real, 64)	28	60	102	354
Formatted (ASCII)	75	254	492	1900

#### Entering HP 8711 data into a PC (HP Vectra VL2 4/66)

## Calibration

---

### Measurement calibration

Calibration significantly reduces measurement uncertainty due to errors caused by system directivity, source match, reflection tracking and crosstalk. These analyzers reduce systematic errors with a built-in calibration so that measurements can be made on many devices without performing a user calibration. For greater accuracy, especially for special test setups, the analyzers offer one-port reflection calibration to remove reflection errors, a response calibration to remove transmission tracking error and a response and isolation calibration to remove transmission tracking and crosstalk errors.

The interpolated mode recalculates the error coefficients when the test frequencies or the number of points are changed. The resulting frequency span must be equal to or less than the user calibration frequency span. System performance is not specified for measurements with interpolated error correction applied.

### Calibrations available

#### Transmission measurements

##### Normalization

Simultaneous magnitude and phase correction of frequency response errors for transmission measurements. Requires a through connection. Used for both narrowband and broadband measurements. Does not support interpolation.

##### Response

Simultaneous magnitude and phase correction of frequency response errors for transmission measurements. Requires a through connection.

##### Response and isolation

Compensates for frequency response and crosstalk errors. Requires a load termination on reflection and transmission ports and a through connection.

#### Reflection Measurements

##### One-port calibration

Calibrates reflection port to correct directivity, tracking and source match errors. Requires an open, short, and load.

### Calibration kits

Data for several standard calibration kits are stored in the instrument for use by calibration routines. They include:

- 3.5 mm (choose HP 85033C or HP 85033D)
- type-F 75 ohm (choose HP 85039A)
- type-N 50 ohm (choose HP 85032B/E)
- type-N 75 ohm (choose HP 85036B/E)

In addition you can also describe the standards (for example, open-circuit capacitance coefficients, offset short length, or fixed loads) of a user-defined kit.

The following calibration kits available from HP contain precision standards in many different connector types. For further information, consult the *RF Economy Network Analyzer Configuration Guide*, HP literature number 5962-9928E.

##### HP 85032B/E 50 ohm type-N calibration kit

Contains precision 50 ohm type-N standards used to calibrate the analyzer to measure of devices with 50 ohm type-N connectors. E versions do not contain adaptors or female standards.

##### HP 85036B/E 75 ohm type-N calibration kit

Contains precision 75 ohm type-N standards to calibrate the analyzer to measure of devices with 75 ohm type-N connectors. E versions do not contain adaptors or female standards.

##### HP 85039A type-F calibration kit

Contains 75 ohm type-F standards to calibrate the analyzer to measure devices with type-F connectors.

##### HP 85033D Option 001 3.5 mm calibration kit

Contains precision 3.5 mm standards to calibrate the analyzer to measure devices with 3.5 mm or SMSA connectors.

## Options

---

### Standard options

#### AM delay (Option 1DA – 50 ohms, or Option 1DB – 75 ohms)

This option adds amplitude modulation group delay capability, which allows measurements of group delay through frequency-translation devices such as tuners or mixers. Using two external scalar detectors (HP 86200B or HP 86201B) and a power splitter (all included) this option measures group delay in any device that does not have limiting circuits, saturated amplifiers, or automatic gain control.

<b>Aperture</b>	55.56 kHz
<b>Resolution</b>	1 ns /division
<b>Accuracy<sup>3</sup></b>	±4 ns
<b>Delay range</b>	30 msec, (9000 m)
<b>Amplitude range</b>	-10 to + 13 dBm (typical)

<b>Change from calibration power</b>	<b>Delay</b>
0 to 10 dB	±10 ns
10 to 20 dB	±20 ns

#### AM delay dynamic accuracy (typical)<sup>4</sup>

#### 75 ohms (Option 1EC)

Provides 75 ohm system impedance.

#### IBASIC (Option 1C2)

This option adds a resident IBASIC system controller, facilitating automated measurements and control of other devices. Using keystroke recording for the simplest applications, or an optional keyboard to write complex control and calculation programs, IBASIC improves productivity by customizing your measurements.

#### Step attenuator (Option 1E1)

This option adds a built-in 60 dB step attenuator, extending the source minimum power to -60 dBm.

#### Fault location and structural return loss software (Option 100)

For fully characterizing cable performance, providing *both* fault location and structural return loss. Structural return loss is a special case of return loss measurements. Physical damage of cable, by handling or manufacturing process, causes reflections. Structural return loss occurs when these periodic reflections sum at half-wavelength spacing and reflect the input signal.

### Special options

#### Switching test sets (Special Option K02)

Switching test sets enhance productivity by allowing multiple measurements with a single connection to the device under test. They are available in several configurations. Call your local HP sales office for more information.

3. Specified at 0 dBm, 16 averages, well-matched device, normalized.

4. Normalized at +10 dBm

## General characteristics

---

### Front panel connectors

<b>Connector type</b>	type-N female
<b>Impedance</b>	50 ohms (standard) 75 ohms (Option 1EC)
<b>Probe power</b>	+15V 200 mA -12.6V 250 mA

### Rear panel connectors

<b>External reference</b>	10 MHz, > -5 dBm, 50 ohm BNC
---------------------------	---------------------------------

### Auxiliary input

The auxiliary input measures the DC level at each sweep point. If the slew rate on this input exceeds 700 mV/msec, increased measurement errors will result.

Calibrated range	±10V
Accuracy	±(3 % or reading +20 mV)
Damage level	>15 Vdc

### External trigger

Triggers on a negative TTL transition or contact closure to ground.

### Limit test output

Provides an open collector TTL high signal. The output is pulled low when the limit test fails.

### User TTL input/output

Provides a bi-directional open collector TTL signal that can be accessed by IBASIC.

### Video output

Provides an RS-343A compatible multisync video signal. Pixel rate is 33.3 MHz, vertical rate is 60 Hz, and horizontal rate is 24.1 kHz. Output is not compatible with EGA or VGA monitors.

### HP-IB

Allows communications with compatible devices including external controllers, printers, plotters, disk drives, and power meters.

### X and Y external detector inputs

Provides for two external detector inputs. See *HP 86200B and 86201B Technical Specifications*, HP literature number 5962-9931E.

### Parallel port

This 25-pin female connector is used with parallel (or Centronics interface) peripherals such as printers and plotters. It can also be used as a general-purpose I/O port, with control provided by IBASIC.

### RS-232C

This 9-pin male connector is used with serial peripherals such as printers and plotters.

### DIN keyboard

This connector is used for adding an IBM PC-AT compatible keyboard for titles, remote front-panel operation, and for IBASIC programming (Option 1C2).

### Line power

47 to 60 Hz  
115V nominal (90V to 132V) or 230V nominal (198V to 264V)  
230 VA max. A three-wire ground is required.

## Environmental characteristics

### General conditions

RFI and EMI susceptibility defined by CISPR Publication 11.

ESD (electrostatic discharge) should be minimized by the use of static-safe work procedures and an antistatic bench mat (such as an HP 92175T).

The sealed flexible rubber keypad protects key contacts from dust, but the environment should be as dust-free as possible for optimal reliability.

### Operating environment

Temperature	0° to 55° C
Humidity	5% to 95% at 40° C (noncondensing)
Altitude	0 to 4,500 meters (15,000 feet)

### Storage conditions

Temperature	-40° C to +70° C
Humidity	0 to 90% relative at +65° C (noncondensing)
Altitude	0 to 15,240 meters (50,000 feet)

### Cabinet dimensions

The following dimensions exclude front and rear panel protrusion:

179 mm H x 425 mm W x 514 mm D  
(7.0 in x 16.75 in x 20.25 in)

### Weight

Net	20.5 kg
Shipping	30 kg

This document describes the system performance of the HP 8711B and 8713B 50 ohm and 75 ohm (Option 1EC) network analyzers, and provides two kinds of information:

Specifications describe the instrument's warranted performance over the temperature range of 25° ±5° C, unless otherwise stated.

Supplemental characteristics are typical but nonwarranted performance parameters. These are denoted as "typical," "nominal" or "approximate."

**Test hardware includes the following:**

**Network analyzer:** HP 8711B or 8713B  
**Calibration kit:** HP 85032E (50 ohm)  
HP 85036E (75 ohm)  
**Test port cable:** HP part number 8120-6469 (50 ohm)  
HP part number 8120-6468 (75 ohm)

**For more information on Hewlett-Packard Test & Measurement products, applications or services please call your local Hewlett-Packard sales offices. A current listing is available via Web through AccessHP at <http://www.hp.com>.**

**If you do not have access to the internet please contact one of the HP centers listed below and they will direct you to your nearest HP representative.**

**United States:**

Hewlett-Packard Company  
Test and Measurement Organization  
5301 Stevens Creek Blvd.  
Bldg. 51L-SC  
Santa Clara, CA 95052-8059  
1 800 452 4844

**Canada:**

Hewlett-Packard Canada Ltd.  
5150 Spectrum Way  
Mississauga, Ontario L4W 5G1  
(905) 206 4725

**Europe:**

Hewlett-Packard  
European Marketing Centre  
P.O. Box 999  
1180 AZ Amstelveen  
The Netherlands

**Japan:**

Yokogawa-Hewlett-Packard Ltd.  
Measurement Assistance Center  
9-1, Takakura-Cho, Hachioji-Shi,  
Tokyo 192, Japan  
(81) 426 48 3860

**Latin America:**

Hewlett-Packard  
Latin American Region Headquarters  
5200 Blue Lagoon Drive, 9th Floor  
Miami, Florida 33126, U.S.A.  
(305) 267 4245/4220

**Australia/New Zealand:**

Hewlett-Packard Australia Ltd.  
31-41 Joseph Street  
Blackburn, Victoria 3130, Australia  
131 347 Ext. 2902

**Asia Pacific:**

Hewlett-Packard Asia Pacific Ltd.  
17-21/F Shell Tower, Time Square,  
1 Matheson Street, Causeway Bay,  
Hong Kong  
(852) 2599 7070