

## Discontinued Product—Support Information Only

This literature was published years prior to the establishment of Agilent Technologies as a company independent from Hewlett-Packard and describes products or services now available through Agilent. It may also refer to products/services no longer supported by Agilent. We regret any inconvenience caused by obsolete information. For the latest information on Agilent's test and measurement products go to:

[www.agilent.com/find/products](http://www.agilent.com/find/products)

Or in the US, call Agilent Technologies at 1-800-452-4844 (8am–8pm EST)



Agilent Technologies

# HP E8115A/16A/18A Preprocessor Interface for the Motorola CPU32 Microcontrollers

## Product Overview

### For use with Logic Analyzers

### Easy Probing of Your Target System

The HP preprocessor family provides an easy way to connect an HP logic analyzer to a target system using the following Motorola microcontrollers:

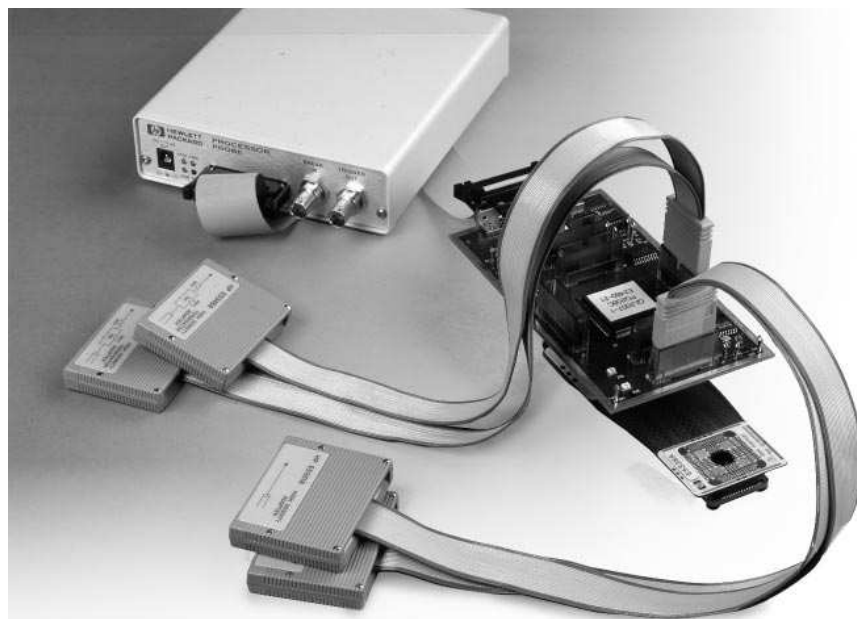
68331/32/34/35	PQFP 132 pin
68331/32/34/35	TQFP 144 pin
68336/76	PQFP 160 pin

Each preprocessor can be modified easily to support any of the CPU32 microcontrollers in this list.

### Control Your Target System with the HP E3458A Processor Probe

In addition to analysis capabilities, hardware and software designers may need to control target processor operation, download new software, and display or modify target memory or internal registers.

These features can be obtained by connecting the preprocessor to the HP E3458A processor probe (figure 2). This tool uses the Motorola BDM port to provide full internal and external visibility of the microcontroller. Please refer to the *HP E3458A Processor Probe Product Overview* for more information.



### A Preprocessor for Hardware and Software Designers

The HP E8115A, E8116A, and E8118A preprocessor family has been designed to provide an extensive set of analysis capabilities to meet the needs of both hardware and software designers in the prototype debug and software development phases of CPU32-based systems.

### From Signal-Level to High-Level Source Code Analysis

While hardware designers need to analyze the prototype at the signal or bus level, software designers expect C source-level visibility during real-time code execution.

All this analysis capability can be delivered simultaneously by an HP E811xA preprocessor connected to any HP logic analyzer with an HP B4620A or B3740A software analyzer tool set.

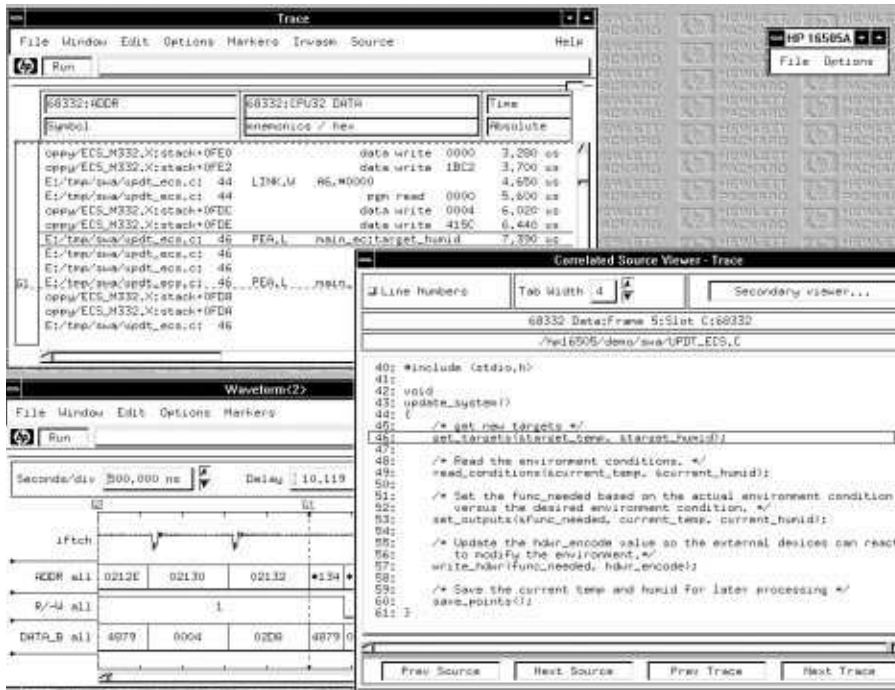


Figure 1: Get a real-time window into the 6833x behavior with source code, time-correlated trace

## Data Sampling Modes

### Timing Analysis

Each preprocessor provides unbuffered timing analysis for all signals.

### State-Per-Clock

In state-per-clock mode, every clock cycle is captured by the logic analyzer, including idle and wait states. Address, data, status and I/O ports are captured on each CPU clock. This mode is useful in hardware validation and when debugging system crashes.

### State-Per-Bus Cycle

In the state-per-bus cycle mode, the analyzer samples address, data, status and I/O ports once per bus cycle. This mode is useful in software debugging because it increases the readability of the executed code and stores more instructions in the logic analyzer's trace memory.

## Enhanced Disassembler

A disassembler included with the preprocessor displays execution traces in CPU32 microcontroller mnemonics. Instructions that are prefetched but not executed are marked in the trace display. Coprocessor operations can also be displayed or removed from the trace. Additionally, when the target microcontroller is configured in show mode, the preprocessor will capture and disassemble internal cycles.

### To Logic Analyzer

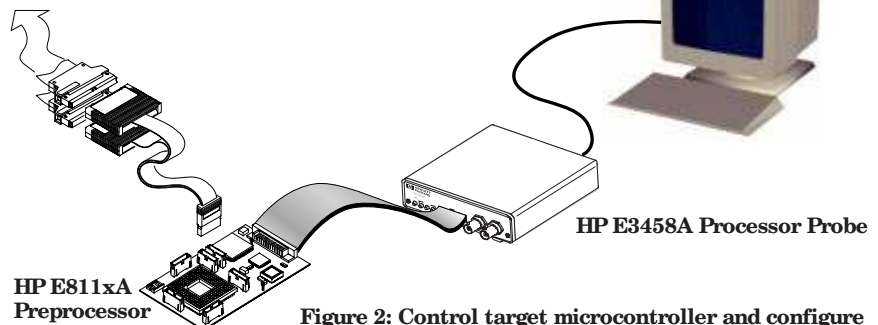


Figure 2: Control target microcontroller and configure preprocessor with an HP E3458A

## Address Reconstruction and Source-Level Display

For software designers who need C source-level visibility during real-time code execution, the preprocessors have been designed to be used in conjunction with the HP B3740A or B4620A software analyzer tool set.

The HP software analyzer tool set provides a correlation between a microcontroller's execution trace window and the corresponding high-level source code window. The HP software analyzer reads the microcontroller's address bus value in each trace sample and finds the corresponding source line by using the symbolic information provided in the code's object file.

The preprocessor supports all CPU32 working modes, even those using address bus pin reallocation. For example, an address bus pin can be reallocated as an I/O port pin. Since the HP software analyzer tool set expects a complete address value to perform mnemonic-to-source translation, the preprocessor reconstructs A19-A23 as needed and provides the analyzer with a complete 24-bit address.

To reconstruct the address bus, the preprocessor needs to be configured at least once for each different setup of a microcontroller's Chip Select registers. This configuration is done with the HP E3458A processor probe connected to the preprocessor and to any ASCII terminal via RS-232 or LAN. Once configured, the preprocessor keeps the address reconstruction parameters in a local EEPROM. The analyzer or the target system can be powered down without having to reload the preprocessor's configuration.

## Product Structure

By ordering the following preprocessor model numbers, you will receive all necessary boards, QFP probes, four high-density adapter cables, and configuration files to analyze and disassemble microcontroller address, data, status, and I/O port lines in state or timing mode.

### Preprocessor Model #

#### E8115A

- Processor: 68331, 68332, 68334, 68335
- Package: PQFP 132 Pin

#### E8116A

- Processor: 68331, 68332, 68334, 68335
- Package: TQFP 144 Pin

#### E8118A

- Processor: 68336, 68376
- Package: PQFP 160 Pin

Each preprocessor includes four high-density cables for connection to eight analyzer pods and configuration software to set up the HP logic analyzer for compatibility with the preprocessor interface.

Two additional HP E5346A high-density adapter cables are necessary to provide simultaneous state and timing analysis of address, data and status lines, coupled with

## Analysis Pod Requirements

State analysis of reconstructed address, data and status busses. Allows trace disassembly and source-level analysis.	State/timing analysis of I/O ports.	Timing analysis of address, data and status busses.
4 analyzer pods required (68 channels)	4 analyzer pods required (68 channels)	4 analyzer pods required (68 channels)

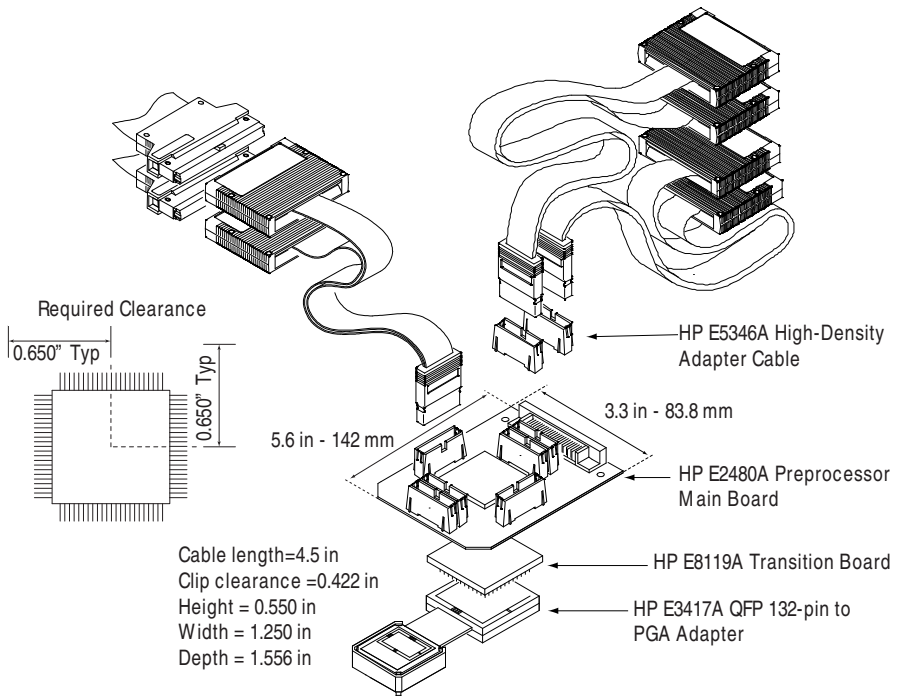
I/O port analysis. These two cables allow connection to four additional pods (68 channels) on the logic analyzer.

preprocessor product will include different probe adapters depending on the package of your target microcontroller.

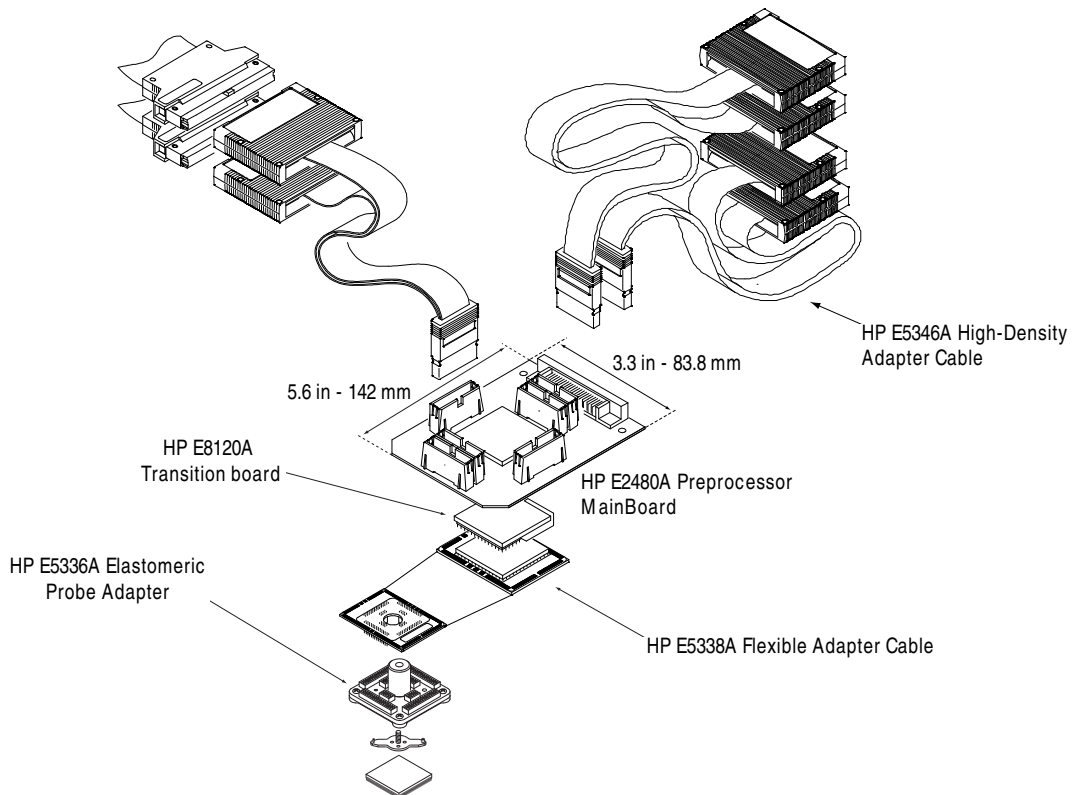
## Preprocessor Structure and Probing Technologies

Probing fine pitch QFP parts has become increasingly difficult over the past several years. Hewlett-Packard has developed several advanced probing adapters for 0.5 mm and 0.65 mm high-density PQFP and TQFP packages. The

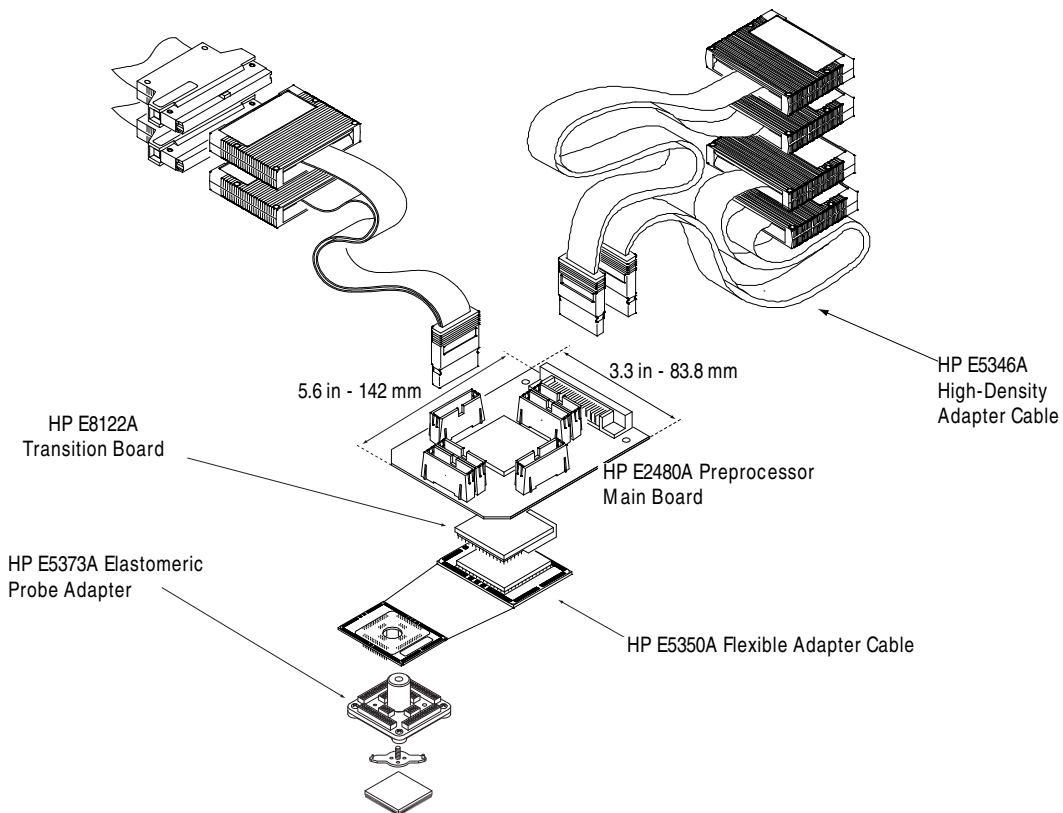
The HP probe adapter provided with the HP E8115A provides a connection to 132-pin JEDEC Ceramic Quad Flat Pack (CQFP) or Plastic Quad Flat Pack (PQFP) microprocessors. The HP probe adapter assembly mounts on top of the microcontroller soldered on the target system.



**Figure 3: HP E8115A Preprocessor for Motorola 68331/32/34/35 PQFP 132 pin**

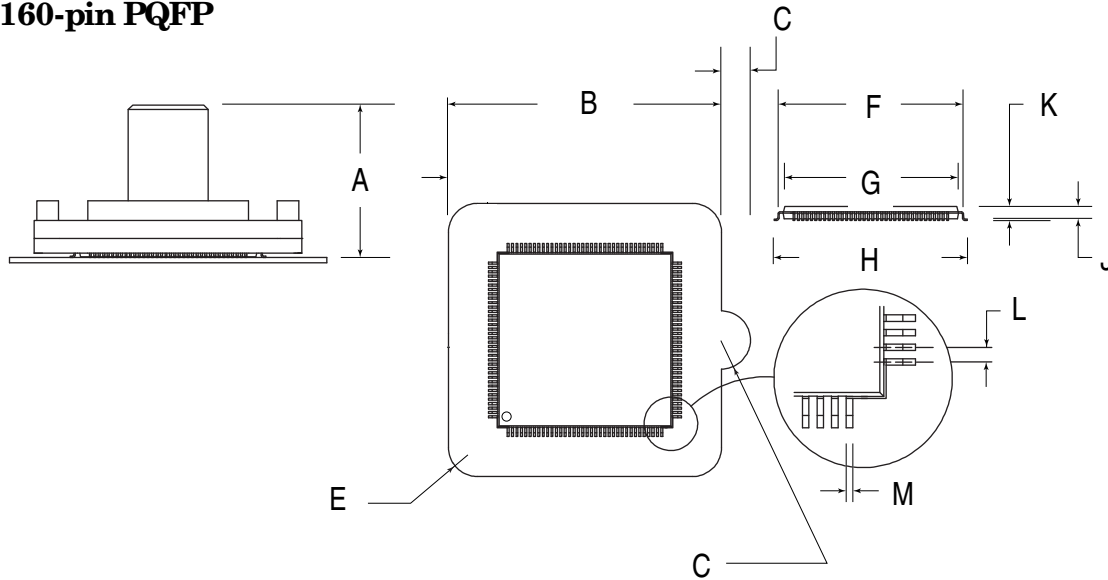


**Figure 4: HP E8116A Preprocessor for Motorola 68331/32/34/35 TQFP 144 pin**



**Figure 5: HP E8118A Preprocessor for Motorola 68336/76 PQFP 160 pin**

## Elastomeric Probe Dimensions for 144-pin TQFP and 160-pin PQFP



Adapter	A	B	C	E	F	G	H	J	K	L	M
<b>144-Pin TQFP</b>											
(inches)	0.67	1.24	0	0.14	0.827 (min)	0.795 (max)	0.866 +/- 0.008	0.053 to 0.057	0.057 to 0.063	0.020 +/- 0.02	0.009 +/- 0.02
(millimeters)	17.13	31.5	0	3.5	21.00 (min)	20.20 (max)	22.00 +/- 0.20	1.35 to 1.45	1.45 to 1.60	0.50 +/- 0.03	0.22 +/- 0.05
(max)	22.00										
<b>160-PIN PQFP</b>											
(inches)	0.76	1.58	0.16	0.15	1.154 (min)	1.106 (max)	1.266 (max)	0.126 to 0.146	0.136 to 0.161	0.03	0.087 to 0.015
(millimeters)	19.2	40.21	4	3.8	29.32 (min)	28.10 (max)	32.15 (max)	3.20 to 3.70	3.45 to 4.10	0.65	0.22 to 0.38

## Detailed Product Matrix

This matrix can be used to order separate parts of a preprocessor or to adapt your current configuration for another processor.

Preprocessor Product Model Number:	Preprocessor Main Board	Transition Board	Probe Assembly	High Density Adapter Cables
E8115A	Includes: E2480A	E8119A	E3417A : 132-pin adapter	E5346A (Qty 4)
E8116A	Includes: E2480A	E8120A	E5338A : Flex cable E5336A : 144-pin adapter	E5346A (Qty 4)
E8118A	Includes: E2480A	E8122A	E5350A : Flex cable E5373A : 160-pin adapter	E5346A (Qty 4)

## Key Specifications

Active Preprocessor	Power supplied by the HP logic analyzer
Maximum Clock Speed	25 MHz
Termination Adapters	None are required
Signal Loading	10pf max on any signal
Voltages	Both 3.3 Volts and 5 Volts are supported by all preprocessors

## Ordering Information

---

### Logic analysis system

- 166xC/CS/D/DS Portable logic analyzers
- 167xA/D Deep memory portable logic analyzers
- 16500C Modular logic analyzer with HP 1655xA analysis boards
- 16505A Prototype analyzer

### Preprocessor

- E8115A Preprocessor for 68331, 68332, 68334, 68335 in PQFP 132-pin package
- E8116A Preprocessor for 68331, 68332, 68334, 68335 in TQFP 144-pin package
- E8118A Preprocessor for 68336, 68376 in QFP-160 pin package.

### Software analysis tool set

- B3740A Software analysis tool for PC or workstation
- #AAV Sun SPARCstation, media and manuals
- #AAV HP 9000 series 700, media and manuals
- #AJ4 IBM, 3 1/2" media and manuals
- #UBK Sun SPARCstation, single-user license
- #UBY HP 9000 series 700, single-user license
- #UDY IBM, single-user license
- B4620A Software analysis tool set for the HP 16505A prototype analyzer

### Processor probe

- E3458A Processor probe for run-control through BDM interface and preprocessor configuration. Includes graphical interface on HP 16505A prototype analyzer

Note : The HP E3458A processor probe can also be controlled by third-party debuggers on HP or Sun workstations

## Warranty Information

---

This Hewlett-Packard product has a warranty against defects in material and workmanship for a period of one year from date of shipment. During this warranty period, Hewlett-Packard Company will, at its option, either repair or replace products that prove to be defective.

## Related HP Literature

---

*HP 16500C Logic Analysis and HP16505A  
Prototype Analyzer, 5965-3187E*

*The HP 1660C/CS and HP 1670-Series  
Logic Analyzers, 5964-3665E*

*The HP B4620A Software Analyzer Tool Set, 5964-9333E*

*The HP B3740A Software Analyzer, 5962-7114E*

*The HP E3458A Processor Probe for the Motorola CPU 32 Series  
Microcontroller, 5965-6676E*

For more information about Hewlett-Packard test & measurement products, applications, services, and for a current sales office listing, visit our web sites,  
<http://www.hp.com/go/tmdir>  
<http://www.hp.com/go/emulator>  
<http://www.hp.com/go/logicanalyzer>

You can also contact one of the following centers and ask for a test and measurement sales representative.

**United States:**  
**Hewlett-Packard Company**  
**Test and Measurement Call Center**  
**P.O. Box 4026**  
**Englewood, CO 80155-4026**  
**1 800 452 4844**

**Canada:**  
**Hewlett-Packard Canada Ltd.**  
**5150 Spectrum Way**  
**Mississauga, Ontario**  
**L4W 5G1**  
**(905) 206 4725**

**Europe:**  
**Hewlett-Packard**  
**European Marketing Centre**  
**P.O. Box 999**  
**1180 AZ Amstelveen**  
**The Netherlands**  
**(31 20) 547 9900**

**Japan:**  
**Hewlett-Packard Japan Ltd.**  
**Measurement Assistance Center**  
**9-1, Takakura-Cho, Hachioji-Shi,**  
**Tokyo 192, Japan**  
**Tel: (81-426) 56-7832**  
**Fax: (81-426) 56-7840**

**Latin America:**  
**Hewlett-Packard**  
**Latin American Region Headquarters**  
**5200 Blue Lagoon Drive**  
**9th Floor**  
**Miami, Florida 33126**  
**U.S.A.**  
**(305) 267 4245/4220**

**Australia/New Zealand:**  
**Hewlett-Packard Australia Ltd.**  
**31-41 Joseph Street**  
**Blackburn, Victoria 3130**  
**Australia**  
**1 800 629 485**

**Asia Pacific:**  
**Hewlett-Packard Asia Pacific Ltd**  
**17-21/F Shell Tower, Times Square,**  
**1 Matheson Street, Causeway Bay,**  
**Hong Kong**  
**Tel: (852) 2599 7777**  
**Fax: (852) 2506 9285**

Technical information in this document is subject to change without notice

Printed in U.S.A. 11/97  
5965-5904.E