

This literature was published years prior to the establishment of Agilent Technologies as a company independent from Hewlett-Packard and describes products or services now available through Agilent. It may also refer to products/services no longer supported by Agilent. We regret any inconvenience caused by obsolete information. For the latest information on Agilent's test and measurement products go to:

www.agilent.com/find/products

Or in the U.S., call Agilent Technologies at 1-800-452-4844 (8am-8pm EST)



Agilent Technologies

Innovating the HP Way

HP 8590E-Series DECT Measurement Solutions



Product Overview

HP 85723A DECT Measurements Personality
HP 859XE Option 012 DECT Source
HP 859XE Option 112 DECT Demodulator

The testing of DECT transmitters provides some complex measurement challenges which until now have proved difficult without using a range of expensive test equipment. The HP 85723A DECT measurements personality enhances the capability of the HP 8590E series of spectrum analyzers, simplifying the key transmitter measurements for testing DECT portable and fixed parts. The DECT personality gives you the functionality to do one-button tests for the key DECT transmitter measurements. Features such as automatic channel selection, power versus time templates and frequency deviation measurements simplify the configuration for your measurements and allow for quick and easy testing of your DECT transmitter.

The spectrum analyzer with DECT measurements personality is an ideal tool for R&D where its flexibility allows for real time pass/fail measurements on transmitters. For production testing the HP 8590E-series and the HP 85723A measurement functions are all accessible via remote control to make the system suitable for an automated production test environment.



The HP 8590E options 012 and 112 complete the spectrum analyzer solution for your DECT transceiver testing needs. The option 112 DECT demodulator card, gives the capability to analyze the modulation on the transmitted DECT signals and display the demodulated data in real time on the spectrum analyzer screen.

The HP 8590E option 012 DECT source provides a built in DECT stimulus, allowing you to perform receiver sensitivity or RF sub assembly testing.

Measurements available in the HP 85723A DECT personality include:

Carrier power
Power versus Time template
Spurious Emissions
Intermodulation Attenuation
Adjacent channel power due to modulation and transients
Frequency Error
Frequency Deviation

Now includes*

Standard and Extended DECT channels • Increased measurement Speed
Real-time FM Measurement • Improved adjacent channel power operation

*Applies to 85723A Rev B.00.00 and above

DECT one-button measurements

Transmitter Carrier Power

ETS 300-176, Section 10

The parameters of a TDMA pulsed signal can be measured using the powerful one-button measurements available in the HP 85723A DECT personality. By just pressing one key, you can measure the normally transmitted power (NTP) with the results for mean carrier power being displayed in a numerical readout with a pass/fail flag.

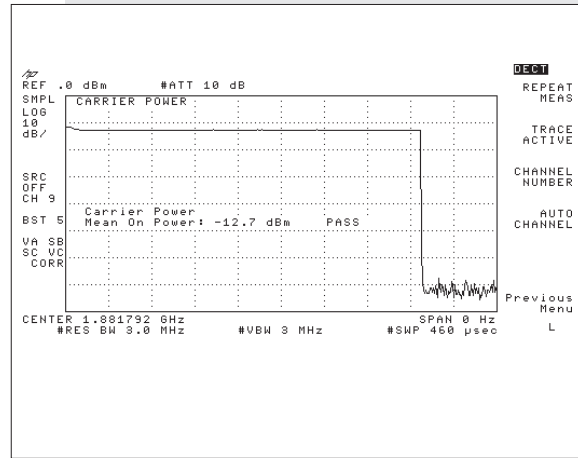

Power versus Time

ETS 300-176, Section 9

A full TDD frame or just the rising and falling edges of the pulsed signal can be analyzed using the HP 85723A DECT measurements personality. The timing of this pulse is vital to ensure that the ramp up and down of the pulse edges fall within the required DECT specification. Limit line testing allows for easy verification of your DECT transmitter with rising edge, falling edge and full frame templates. For a static trace the 110 dB of on screen dynamic range clearly shows the complete pulse shape.

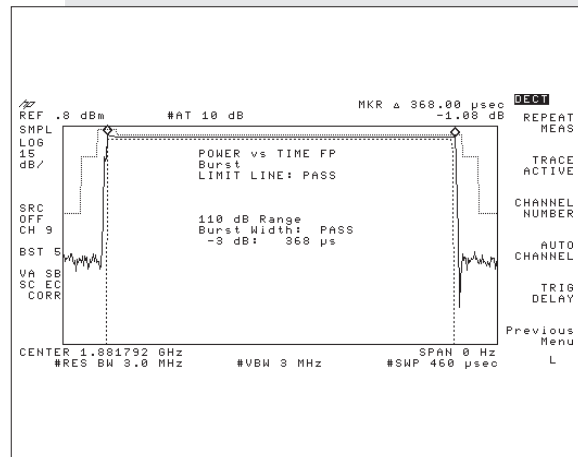

Adjacent Channel Power

Due to Modulation and Transients
ETS 300-176 Sections 12.1 & 12.2

The HP 85723A DECT measurements personality allows measurement of the total power in all of the DECT channels relative to that of the transmit channel. The analyzer will scan through all these channels and use a time gating technique to eliminate the spectral components due to switching transients, leaving only the spectral components due to the GFSK modulation. Once the measurement is complete, results are displayed on screen in a tabular format.

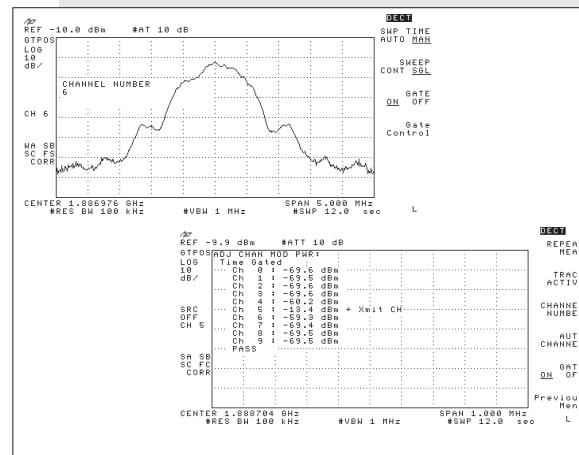

Spurious Emissions

In transmit and idle mode
ETS 300-176 Sections 12.5 & 13.7

Take full advantage of the wide dynamic range of the HP 8590E-series spectrum analyzers for spurious emissions testing. A one-button automatic spurious search routine is available within the HP 85723A DECT personality. The spectrum analyzer will scan all the way across the specified frequency band and will detect all the spurious signals which exceed a user defined limit. These spurs can be listed in a table or examined more closely by zooming in. The upper frequency limit is defined by the spectrum analyzer used, but you have complete control over the settings within that range.

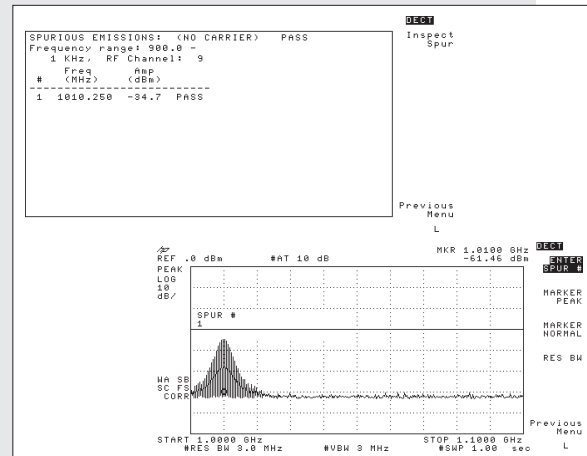

Intermodulation Attenuation

ETS 300-176 Section 12.4

Using the one-button intermodulation test, you can quickly and easily find any third order intermodulation products generated by the transmitter. These can be displayed clearly on screen by using time gating to measure only the intermodulation products due to the GFSK modulation without the edge transients. Along with the on screen trace, the amplitudes of the intermodulation products are displayed with a pass/fail flag.

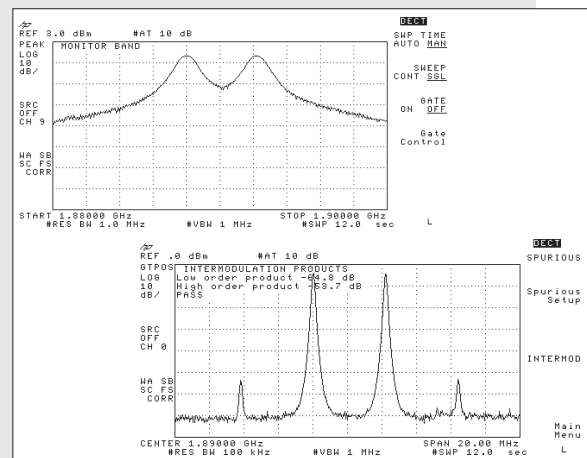

Frequency Error and Frequency Deviation

ETS 300-176 Sections 7 & 11

The option 112 DECT demodulator card for the HP 8590E spectrum analyzer, gives a real time display of the carrier frequency error and peak frequency deviation. The demodulated DECT burst can be captured and stored in the analyzer memory and then displayed in 80 ms segments so you can inspect the DECT packet down to its component bits. The median frequency error calculates the difference between the transmitted DECT signal and the specified DECT channel frequency.

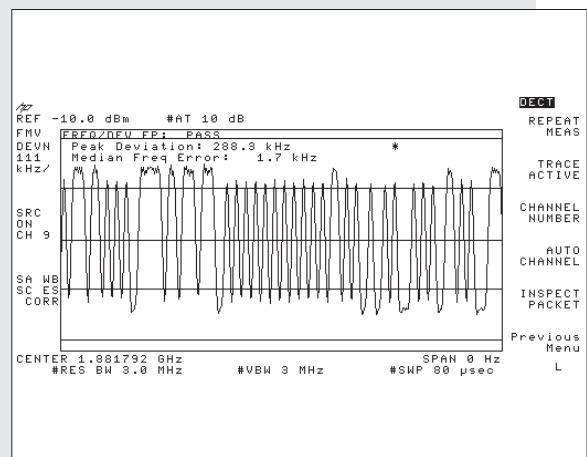

DECT Source

For DECT receiver measurements, the HP 8590E option 012 DECT source offers the capabilities of a standalone signal generator for a fraction of the cost. The built in tracking generator available for the HP 8593/4/5/6E spectrum analyzers can be configured to generate a DECT modulated signal so you don't need to invest in a standalone RF signal generator. The option 012 DECT source operates by pulse modulating the tracking generator output. When a DECT protocol generator is used to supply DECT data, the source filters this data with a 0.5 GFSK filter before applying it to the RF carrier.

To generate a DECT signal, you need only supply two inputs for operation of the DECT source

1. TDMA burst signal - A TTL signal is used to control the pulse modulation of the tracking generator source to create a pulsed DECT carrier.
2. Data input - A TTL data input must be applied to the rear panel to provide DECT protocol to modulate onto the tracking generator.

The source can generate a DECT modulated signal in the band 1.88 GHz to 1.9 GHz or in normal tracking generator operation can generate a sweeping signal in tune with the analyzer. The HP 85723A personality can fully control the DECT source and will automatically tune the output frequency to the DECT channel at which the spectrum analyzer is set. The output amplitude range of the source covers -21 dBm to -83 dBm, making it an ideal tool for receiver sensitivity measurements.

Using the HP 8590E spectrum analyzer configured with the option 012 DECT source and the option 112 DECT demodulator opens the door to bit error rate testing on your DECT transceiver. Using the DECT source to transmit a signal to the DECT transceiver, a DECT protocol generator can be used to supply a known sequence of data to the TTL data input connector to modulate onto the RF carrier.

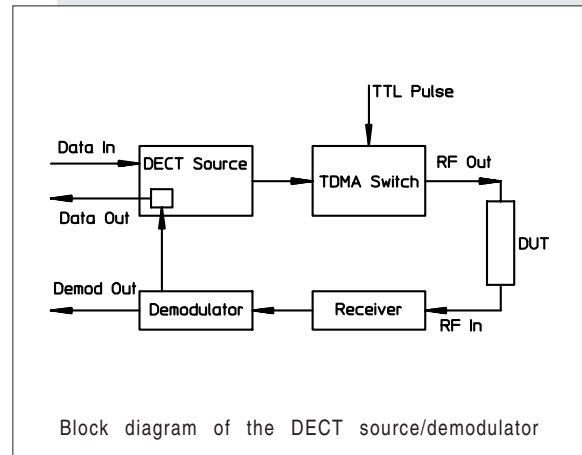
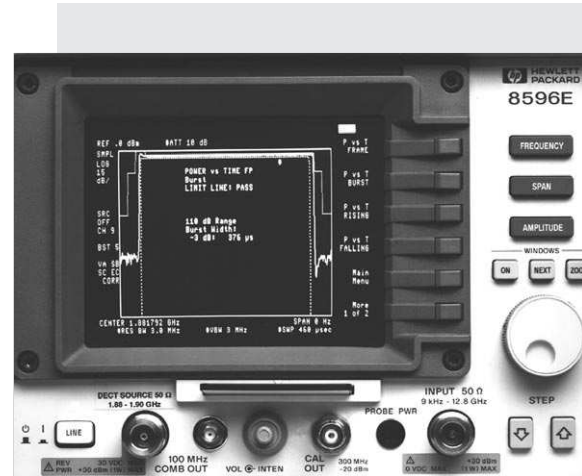

Block diagram of the DECT source/demodulator

Once the DECT transceiver is put in loopback mode, the signal transmitted from the DECT source will be received and re-transmitted by the transceiver. The option 112 DECT demodulator can then be used to demodulate this signal which can be examined on screen and is also available via the rear panel TTL data output connector. With the use of a stand-alone BER tester, this output data can then be compared with the original stimulus to allow BER measurements.

HP 85902A Burst Carrier Trigger

The HP 85902A burst carrier trigger (BCT) is an accessory device intended for use with the HP 859XE family of spectrum analyzers for measuring TDMA or TDD carriers, where a trigger signal is required. For typical TDMA or TDD measurements, the pulsed carrier is split into two paths using a power splitter. One path connects to the input of the spectrum analyzer and the other connects to the RF input of the BCT. In the BCT, the signal is detected by an RF detector, amplified by a 70 dB AGC amplifier and sent to a trigger comparator. When the amplified signal exceeds the trigger threshold level, the trigger comparator switches state and provides a pulse which can be applied to the spectrum analyzer to trigger the measurement. The BCT internal amplifier has a nominal gain of 15 dB to improve the sensitivity of the RF detector. This amplifier has its own input and output connectors and can be used as a stand alone pre-amplifier with power provided from the probe power connector on the spectrum analyzer front panel. Applications for the HP 85902A BCT include power versus time, carrier power and gated adjacent channel power measurements for DECT, CT2, GSM, NADC, JDC, DCS1800 and PHP digital communications formats.

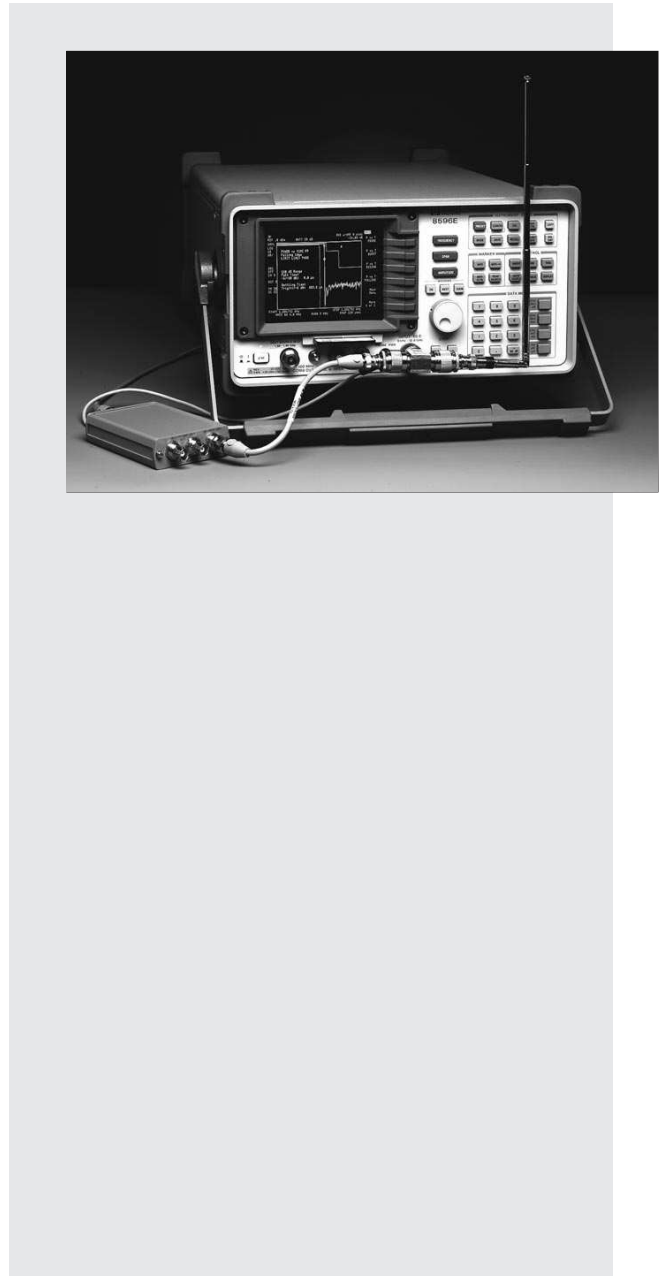

Quality Spectrum Analyzers

Fit an analyzer to your needs

HP has a family of portable spectrum analyzers covering the frequency ranges 9 kHz up to 26.5 GHz. This gives you high-quality spectrum analysis with the added capabilities to make dedicated measurements on DECT transmitters.

Powerful yet portable

The HP 8590-series analyzers offer a marker count frequency accuracy of ± 358 Hz at 1880 MHz when the option 004, precision frequency reference is installed. An external 10 MHz frequency reference can also be used for improved frequency stability. Firmware functions provide the ability to do limit line testing, trace math, Fourier transform and storage of traces and states. The built in-clock and calendar function can be used to time-and-date stamp traces before storage to a RAM card or the analyzers internal memory.

Flexibility for the future

A built-in card cage allows the hardware configuration of the analyzer to be adapted for different measurement needs. The circuit cards containing the analyzer options are retrofittable so upgrades are always available.

Some of the circuit cards necessary for DECT measurements are :

Option 101, fast time domain sweeps. This option allows zero span sweep times as fast as 20 ms.

Option 105, time gated spectrum analysis provides the capability to analyze pulsed RF signals. The analyzer is set up to measure the RF signal on the input only for a specified gate time. This gate time is variable from 1 ms up to 65 ms with a 1 ms resolution. This allows a much clearer measurement of the contents of a pulsed signal as all of the edge transients of the pulse are rejected. Option 112, DECT

demodulator card. This card gives the capability to demodulate DECT signal packets to do frequency deviation and frequency error measurements. Note: the HP 53310A option 031 modulation analyzer may be used in applications where greater accuracy is called for.

Model	Frequency Range (GHz)					
	0	2.9	6.5	12.8	22	26.5
HP 8594E	9 kHz-2.9 GHz					
HP 8595E	9 kHz-6.5 GHz					
HP 8596E	9 kHz-12.8 GHz					
HP 8593E	9 kHz-22 GHz					Opt.

Note: As DECT covers the frequency range 1880 to 1900 MHz, the HP 85723A is not supported on the HP 8591E as their frequency range only extends to 1800 MHz.

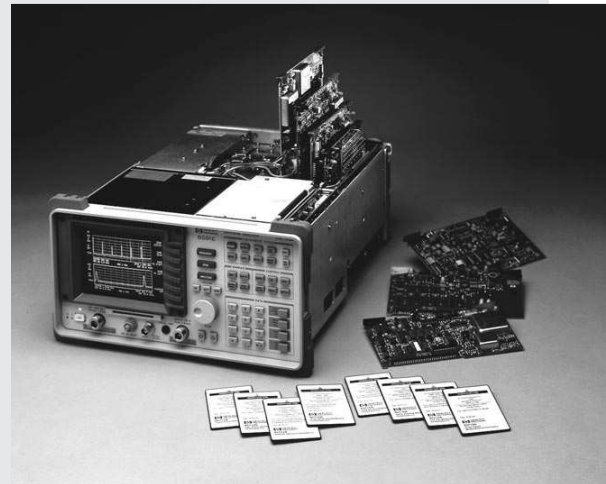

Measurements using the HP 53310A Modulation Domain Analyzer

The HP 53310A option 031 Modulation Domain Analyzer is the ideal complement to the HP 8590E-series of analyzers when you require higher precision frequency error, frequency deviation, frequency drift and jitter measurements. The HP 53310A option 031 offers a view of information which other measurement techniques miss, the modulation domain. The HP 53310A option 031 provides built-in analysis such as automatic center frequency and peak deviation to simplify DECT testing.

Jitter analysis is simplified with automated mean, standard deviation and probability functions. Option 031 (Digital RF Communications Analysis/High Resolution 2.5 GHz input), provides the capability to accurately measure - Carrier center frequency - Peak Frequency deviation - Frequency drift over a burst - Jitter, all within the DECT specifications.

The option 031 downconverts the RF signal to provide finer frequency resolution. Once the signal has been downconverted, fast sample rates up to 7.5 MHz can be achieved for repetitive signals. This modulation bandwidth means that DECT data can be easily demodulated. Measurement setup is further simplified by automatically triggering on the RF envelope of the TDMA burst.

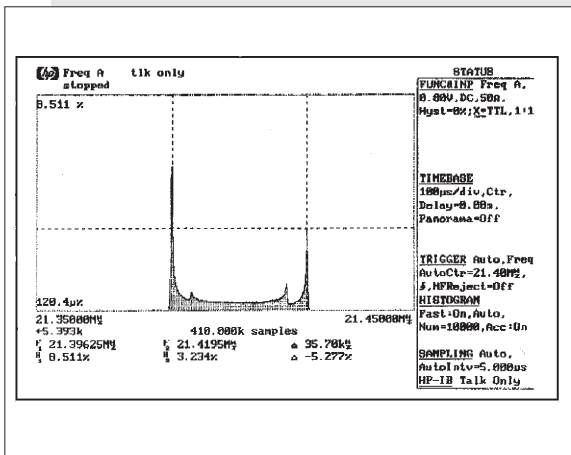

Specifications

Specifications describe the instrument's fully warranted performance. Characteristics provide information about non-warranted instrument performance in the form of nominal values. Characteristics are denoted in italics.

A positive or negative TTL transition is required to synchronize the measurement system with the transmitter under test. The synchronization signal must occur once per DECT timeframe. A trigger signal is required for the carrier power, power vs. time, and modulation measurements.

General

Maximum Safe Input Level: Total power must not exceed +30 dBm or 1 watt.

Internal Freq Reference: Option 004 $\pm 1 \times 10^{-7}$ /year (aging only)

Carrier Power

Range: +26 dBm to -35 dBm

Absolute Amplitude Accuracy: ± 4.5 dB, ± 2.0 dB RSS

Relative Amplitude Accuracy
0 to -60 dB from Fixed Ref Lvl: ± 0.75 dB

Adjacent Channel Power (ACP) due to Modulation and Intermodulation Attenuation

Integration bandwidth (RBW 100 kHz): 1 MHz $\pm 3\%$

Range of Spectrum Before Integration: *Adjacent channel power: +26 dBm to -60 dBm*
Intermodulation attenuation: +26 dBm to -40 dBm

Absolute Amplitude Accuracy: ± 4.7 dB, ± 2.0 dB RSS

Relative Amplitude Accuracy
0 to -60 dB from Fixed Ref. Lvl: ± 0.75 dB

ACP due to switching transients

Range: +26 dBm to -40 dBm

Absolute Amplitude Accuracy: ± 4.7 dB, ± 2.0 dB RSS

Relative Amplitude Accuracy
0 to -70 dB from Fixed Ref. Lvl: ± 0.75 dB

Power versus Time

Display Range of Waveform, log scale: *select either 0 dB to -70 dB or 0 dB to -110 dB*

Vertical Scale per Division: 1 to 15 dB in 1 dB steps

Relative Amplitude Accuracy
0 to -70 dB from Fixed Ref Lvl: ± 1.0 dB

Time Resolution
Displayed time resolution (μ s):

Test	Burst Size			
	Short	Basic	Low Capacity	High
Capacity				
Frame	25	25	12	25
Burst	0.45	1.15	0.6	2.2
Rising Edge	0.3	0.3	0.3	0.3
Falling Edge	0.3	0.3	0.3	0.3
Carrier On	0.15	0.85	0.35	1.9

Time Error, absolute with respect to external trigger:
(*RBW = 3 MHz, VBW = 3 MHz*)
 $\pm (3 \mu\text{s} + \text{time resolution})$
 $\pm (1.5 \mu\text{s} + \text{time resolution})$

RSS

Time Error, relative:
(*RBW = 3 MHz, VBW = 3 MHz*)
 $\pm (1.3 \mu\text{s} + \text{time resolution})$
 $\pm (1.0 \mu\text{s} + \text{time resolution})$

RSS

Time Accuracy: $\pm 2\%$ of sweep time (ST < 20ms)

Spurious Emissions (total TX power = +17 dBm)

Sensitivity

Transmitter active, 30 kHz RBW, displayed average noise level for the frequency range

1875 MHz to 1880 MHz: -55 dBm
1900 MHz to 1905 MHz: -55 dBm

Transmitter active, 100 kHz RBW, displayed average noise level for the frequency range

1870 MHz to 1875 MHz: -50 dBm

Transmitter active, 300 kHz RBW, displayed average noise level for the frequency range

1860 MHz to 1870 MHz: -45 dBm
1910 MHz to 1920 MHz: -45 dBm

Transmitter active, 1 MHz RBW, displayed average noise level for the frequency range

1850 MHz to 1860 MHz: -40 dBm
1900 MHz to 1902 MHz: -40 dBm

Transmitter active, 3 MHz RBW, displayed average noise level for the frequency range¹

5 MHz to 1850 MHz²: -40 dBm
1930 MHz to 12.75 GHz: -40 dBm

Transmitter idle, no carrier, (ATT=10 dB), 100 kHz RBW, displayed average noise level for the frequency range^{1,3}

30 MHz to 12.75 GHz: -70 dBm

Absolute amplitude accuracy

Frequency Range 100 kHz to 6.4 GHz: ±4.9 dB, ±2.3 dB RSS

Relative Amplitude Accuracy

0 to -60 dB from fixed ref. lvl: ±0.75 dB

¹ Frequency Ranges

HP 8594E: 100 kHz to 2.9 GHz
HP 8595E: 100 kHz to 6.5 GHz
HP 8596E: 100 kHz to 12.8 GHz
HP 8593E: 100 kHz to 22 GHz
(optionally 26.5 GHz)

² Except for frequency bands as follows:

47 MHz to 74 MHz: -55 dBm
87.5 MHz to 108 MHz: -55 dBm
108 MHz to 118 MHz: -55 dBm
174 MHz to 230 MHz: -55 dBm
470 MHz to 862 MHz: -55 dBm

Frequency Error and Peak Frequency Deviation (with option 112)

Total Range from Nominal Carrier Frequency
-440 kHz to +440 kHz

Resolution: 3.7 kHz

Frequency Accuracy: $< \pm 20 \text{ kHz} + (\text{carrier freq}) \times (\text{freq ref error})$

Frequency Temperature Drift: ±1 kHz per degree C

FM Deviation Accuracy at 288 kHz: $< \pm 22 \text{ kHz}$

FM Discriminator 3 dB bandwidth at 288 kHz peak deviation:
dc to 1 MHz

Level Range: +26 dBm to -35 dBm

DECT Source (option 012)

Warm up 30 minutes

Carrier Frequency

Range: 1.88 GHz to 1.9 GHz

Frequency Accuracy: ±(5 kHz + Analyzer Frequency Error)
(at 25°C ±10°C)

Output Power Level

Range: -21 dBm to -83 dBm

Resolution: 0.1 dB

Absolute Accuracy: ±1.5 dB (1.89 GHz, -40 dBm)
(at 25°C ±10°C)

Output Flatness: ±0.5 dB

Modulation

Input - TTL compatible signal

Format - Frequency Shift Keying

Premodulation Filter - Gaussian (BT = 0.5)

Frequency Deviation - 288 kHz fixed

Frequency Deviation Accuracy ±5 kHz

TDMA Switch

Input - TTL compatible signal

On/Off Ratio >75 dB

Spurious Output

Non-harmonic spurs from 1.88 GHz to 1.9 GHz <-40 dBc
(>10 kHz offset)

Output VSWR

0 dB attenuator <2.0 : 1

8 dB attenuator <1.5 : 1

³ ETSI Specification requires that for spurious emission measurements below the second harmonic of the carrier frequency, the filter used shall be a high 'Q' (notch) filter centered on the transmitter carrier frequency and attenuating this signal by at least 30 dB. For the measurement of spurious emissions at and above the second harmonic of the carrier frequency the filter used shall be a high pass filter with a stop band rejection exceeding 40 dB. The cut-off frequency of the high-pass filter shall be approximately 1.5 times the transmitter carrier frequency.

Ordering Information



Recommended Configuration

HP 8593E, HP 8594E, HP 8595E or HP 8596E Portable Spectrum Analyzer

- Option 004** Precision Frequency Reference¹
- Option 012** DECT Source²
- Option 101** Fast Time Domain Sweep Card
- Option 105** Time-Gated Spectrum Analysis Card
- Option 112** DECT Demodulator Card³
- Option J61** ±0.6 dB Amplitude Measurement Accuracy in the DECT Band (1880 MHz to 1900 MHz)

HP 85723A DECT Measurements Personality

Ordering Convenience

HP 8593E, HP 8594E, HP 8595E, HP 8596E Portable Spectrum Analyzer Option E67⁴

Contains:

- Option 004** Precision Frequency Reference¹
- Option 012** DECT Source
- Option 101** Fast Time Domain Sweep Card
- Option 105** Time-Gated Spectrum Analysis Card
- Option 112** DECT Demodulator Card

For enhanced accuracy, frequency error and frequency deviation measurements, and the capability to do frequency drift and jitter measurements

- HP 53310A** Modulation Domain Analyzer
- Option 031** Digital RF Communication High Resolution 2.5 GHz Input

Related Spectrum Analyzer Options

- Option 021** HP-IB Interface
- Option 023** RS-232 Interface
- Option 040** Front Panel Protective Cover

Related Products

- HP 85902A** Burst Carrier Trigger
- HP 85700A** 32 kByte Blank RAM Card
- HP 85702A** 128 kByte Blank Ram Card
- HP C1405A** Option ABA Keyboard (Requires option 021 on the HP 8590E Spectrum Analyzer)
- HP 3630A** Option 001 PaintJet Color Printer with RS-232 interface
Option 002 PaintJet Color Printer with HP-IB interface
- HP 8664A** Option H10 Signal Generator with DECT Option
- HP 8665A/B** Option H10 Signal Generator with DECT Option

For more information about Hewlett-Packard test and measurement products, applications, services, and for a current sales office listing, visit our web site: <http://www.hp.com/go/tmdir>
You can also contact one of the following centers and ask for a test and measurement sales representative.

United States:

Hewlett-Packard Company
Test and Measurement Call Center
P.O. Box 4026
Englewood, CO 80155-4026
(tel) 1 800 452 4844
Canada:

Canada:

Hewlett-Packard Canada Ltd.
5150 Spectrum Way
Mississauga, Ontario
L4W 5G1
(tel) (905) 206 4725

Europe:

Hewlett-Packard Company
European Marketing Centre
P.O. Box 999
1180 AZ Amstelveen
The Netherlands
(tel) (31 20) 547 9900

Japan:

Hewlett-Packard Japan Ltd.
Measurement Assistance Center
9-1, Takakura-Cho, Hachioji-Shi,
Tokyo 192-8510, Japan
(tel) (81) 426 56 7832
(fax) (81) 426 56 7840

Latin America:

Hewlett-Packard Company
Latin American Region Headquarters
5200 Blue Lagoon Drive
9th Floor
Miami, Florida 33126
U.S.A.
(tel) (305) 267 4245/4220
(fax) (305) 267 4288

Australia/New Zealand:

Hewlett-Packard Australia Ltd.
31-41 Joseph Street
Blackburn, Victoria 3130
Australia
(tel) 1 800 629 485 (Australia)
(tel) 0 800 738 378 (New Zealand)
(fax) (61 3) 9210 5489

Asia Pacific:

Hewlett-Packard Asia Pacific Ltd
17-21/F Shell Tower, Times Square,
1 Matheson Street, Causeway Bay,
Hong Kong
(tel) (852) 2599 7777
(fax) (852) 2506 9285

**Data Subject to Change
Copyright © 1998
Hewlett-Packard Limited**

¹ Required unless an external 10 MHz reference is provided
² If option 012 is ordered without the other DECT options (101, 105, 112) the following options are not supported: 009, 010, 102, 103, 110, 111, 119, 130, 140, 151, 301.
³ Options 102, 103 and 110 are not supported with option 112.
⁴ When option E67 is ordered, the options 009, 010, 101, 102, 103, 105, 110, 111, 119, 130, 140, 151, 301, cannot be added.