

---

# Hinged ICA, High Density (21 Slots) HP E3722A Technical Specifications

---

- 21 connector slots, up to 4,032 pins
- Easy wiring from places other than VXI mainframe
- Power connections to 250 Vac, 30 A per pin
- Mounts onto the HP E1401A/B C-size mainframe
- Connector blocks/cables for ICA and ITA

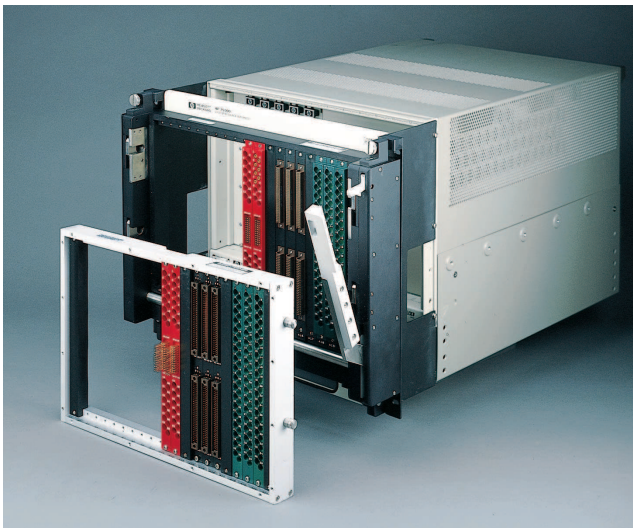

HP E3722A

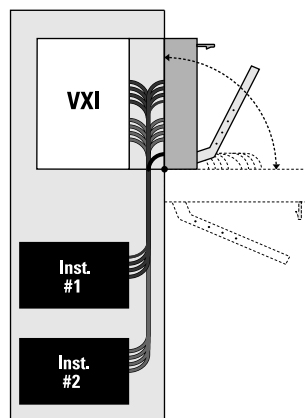

## Description

The HP E3722A Hinged Interface Connector Assembly (H/ICA) provides connections to and from the VXI and other measurement equipment. It mounts directly onto the HP E1401A/B C-size mainframes and mates them to the HP 9421A interface test adapter (ITA). For information on using the HP E3722A with the HP E84XX series mainframes, contact your HP Sales Representative.

The HP E3722A Hinged Interface Connector Assembly (H/ICA) is used under the following conditions: 1) the majority of ICA connections are wired directly to VXI plug-in modules in a single VXI mainframe; 2) up to 4,032 general purpose pins and 250 Vac, 30 A per pin are required; 3) wiring is flexible enough to bend when the fixture is closed; and 4) reduced access and visibility to VXI plug-in modules are acceptable.

The Interface Test Adapter (ITA) provides connections to/from the Unit Under Test (UUT). The HP 9421A Interface Test Adapter (ITA) module mates with the HP E3722A ICA for quick and easy connections. A custom UUT interface may be built onto the ITA.

Additionally, general purpose connector blocks/cable assemblies (HP 914XX, HP 915XX series), coaxial connector blocks/cable assemblies (HP 914XX series), power connector blocks/cable assemblies (HP 914XX series), and special purpose connector blocks/cable assemblies are available for use with the HP E3722A product.



HP E3722A Hinged Interface

## Product Specifications

Height:	40.00 cm (15.75 in)
Width:	48.30 cm (19.00 in)
Depth:	79.20 cm (31.2 in) including mainframe with rear feet
Connector slots:	21
General purpose pins:	Up to 4,032
Power connections:	To 250 Vac, 30 A per pin
Mounts:	HP E1401A/B C-size mainframe, directly

## Ordering Information

Description	Product No.
Hinged interface connector assembly	HP E3722A
<b>Note: See "Connector and Cabling Accessories for Mass Interconnect Products" for ordering information on related accessories.</b>	

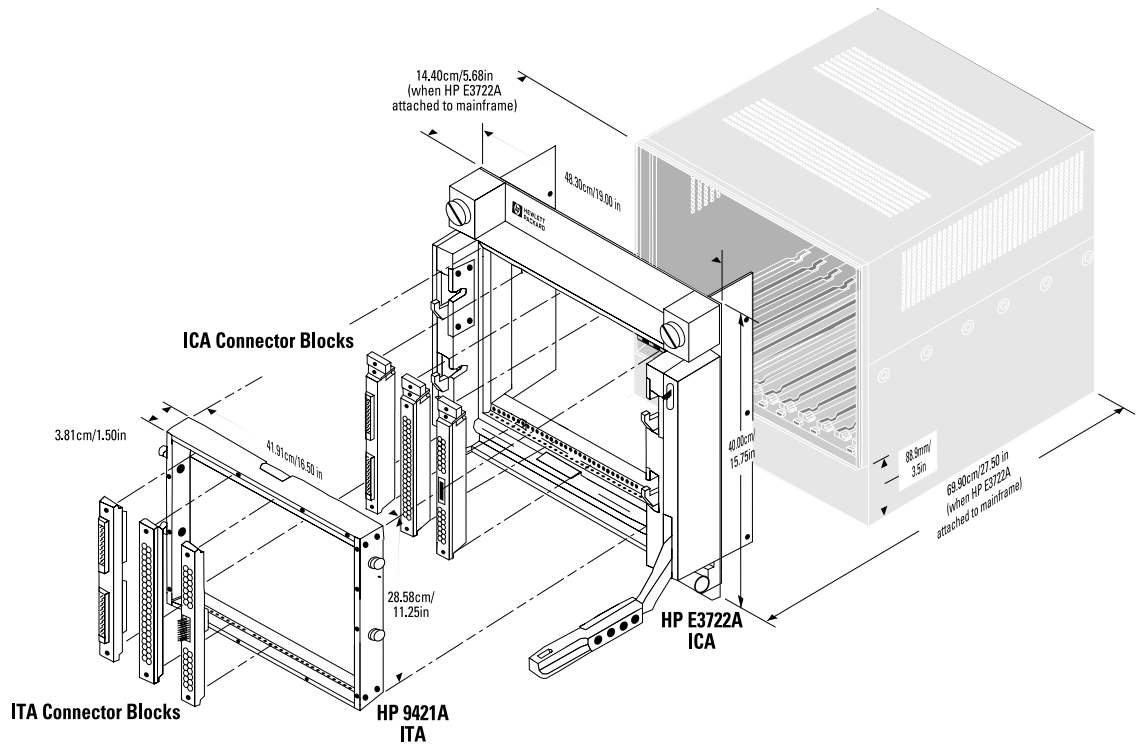

---

**Related Literature**

*1998 Test System and VXI Products Data Book*,  
HP Pub. No. 5966-2812E

*1999 Test System and VXI Products Catalog*,  
HP Pub. No. 5968-3698

---

**Warranty**

Standard Hewlett-Packard VXIbus hardware products are warranted against defects in materials and workmanship for a period of three years unless otherwise noted. HP software and firmware products that are designated by HP for use with a hardware product, when properly installed on that hardware product, are warranted not to fail to execute their programming instructions due to defects in materials and workmanship.

For a complete and detailed warranty statement please see the *HP Test System and VXI Products Data Book* or visit the HP Website at <http://www.hp.com/go/vxi>.

---

**Website Directory**

HP VXI Product Information  
<http://www.hp.com/go/vxi>

HP VXI Channel Partners  
<http://www.hp.com/go/vxichanpart>

HP VEE Application Website  
<http://www.hp.com/go/hpvee>

Data Acquisition and Control Website  
[http://www.hp.com/go/data\\_acq](http://www.hp.com/go/data_acq)

HP Instrument Driver Downloads  
[http://www.hp.com/go/inst\\_drivers](http://www.hp.com/go/inst_drivers)

Electronics Manufacturing Test Solutions  
<http://www.hp.com/go/manufacturing>

**For more information about Hewlett-Packard test & measurement products, applications, services, and for a current sales office listing, visit our website, <http://www.hp.com/go/tmdir>. You can also contact one of the following centers and ask for a test & measurement sales representative.**

**United States:**

Hewlett-Packard Company  
Test and Measurement Call Center  
P.O. Box 4026  
Englewood, CO 80155-4026  
1 800 452 4844

**Canada:**

Hewlett-Packard Canada Ltd.  
5150 Spectrum Way  
Mississauga, Ontario L4W 5G1  
(905) 206 4725

**Europe:**

Hewlett-Packard  
European Marketing Centre  
P.O. Box 999  
1180 AZ Amstelveen  
The Netherlands  
(31 20) 547 9900

**Japan:**

Hewlett-Packard Japan Ltd.  
Measurement Assistance Center  
9-1, Takakura-Cho, Hachioji-Shi,  
Tokyo 192, Japan  
Tel: (81) 426 56 7832  
Fax: (81) 426 56 7840

**Latin America:**

Hewlett-Packard  
Latin American Region Headquarters  
5200 Blue Lagoon Drive, 9th Floor  
Miami, Florida 33126  
U.S.A.  
Tel: (305) 267-4245  
(305) 267-4220  
Fax: (305) 267-4288

**Australia/New Zealand:**

Hewlett-Packard Australia Ltd.  
31-41 Joseph Street  
Blackburn, Victoria 3130  
Australia  
1 800 629 485

**Asia Pacific:**

Hewlett-Packard Asia Pacific Ltd.  
17-21/F Shell Tower, Times Square,  
1 Matheson Street, Causeway Bay,  
Hong Kong  
Tel: (852) 2599 7777  
Fax: (852) 2506 9285

Data Subject to Change  
Copyright © April 1999  
Hewlett-Packard Company  
HP Publication No.: 5965-5579E