

Agilent E1346A

48-Channel Single-Ended Relay Multiplexer

Data Sheet

- 1-Slot, B-size, register based
- 48 single-ended channels
- Common low and guard terminals
- Channel scanning with Agilent DMMs
- Analog bus connector on the faceplate

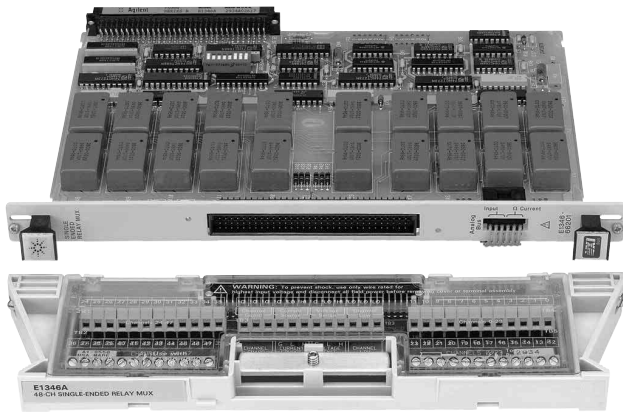

Agilent E1346A

Description

The Agilent E1346A Single-Ended Relay Multiplexer is a **B-size, 1-slot, register-based VXI module** that switches 48 channels of high connections and one channel each of low and guard. This module consists of a component and a terminal block that plugs onto the component card. An analog bus connector on the faceplate provides easy connection to an E1326B DMM, E1411B DMM, and/or other slot-adjacent multiplexers.

Common high, low, and guard signals are connected by tree switch to both the tree-switch terminals on the terminal card and the analog bus connector. Removal of a factory-installed jumper on the component card isolates the low from the guard input. One analog bus cable is shipped with each module, making it easy to connect multiplexer common outputs together for slot-adjacent modules.

Refer to the Agilent Technologies Website for instrument driver availability and downloading instructions, as well as for recent product updates, if applicable.

Configuration

Common high, low, and guard signals are connected by tree switch to both the tree-switch terminals on the terminal card and the analog bus connector. Removal of a factory-installed jumper on the component card isolates the low from the guard input. One analog bus cable is shipped with each module, making it easy to connect multiplexer common outputs together for slot-adjacent modules. If you are using a B-size mainframe, Agilent E1300B or E1301B, use the analog bus cable shipped with the E1326A DMM to connect it to the multiplexer(s).

C-size Adapter

For installing the E1346A in a C-size mainframe, the E1403C active adapter is recommended.



Agilent Technologies

Product Specifications

Input

DC:

Maximum voltage (any terminal to any other terminal or chassis): 120 Vdc

AC rms:

Maximum voltage (any terminal to any other terminal or chassis): 120 V rms

Maximum current (per channel common, non-inductive): 50 mA

Maximum power per channel: 1 VA

DC

Maximum thermal offset per channel, differential

Hi-Lo: 50 μ V

Closed channel resistance: 100 $\Omega \pm 10\%$

Insulation resistance (between any two points): 10E9 Ω

Insulation resistance (Hi to Lo, power off): n/a

AC

Minimum bandwidth (-3 dB, 50 Ω source/load): 10 MHz (protection resistors shorted)

Crosstalk (channel-to-channel):

100 kHz: -70 dB

10 MHz: -20 dB

Both: n/a

Closed channel capacitance: <150 pF Hi-Lo, <150 pF Lo-Guard, <2000 pF Guard-Chassis

General Characteristics

Relays: Reed relays
Break-before-make

Power down state: Relays open on power down

Power up state: Relays open on power up

Minimum relay life:

No load: 10E8 operations

Rated load: 10E7 operations

Screw terminal wire size: 16 to 26 AWG (1.5, 1.2, 0.9, 0.75, 0.5 mm)

Scanning rate: 600 channels/s typ.

General Specifications

VXI Characteristics

VXI device type: Register based, A16, slave only

Size: B

Slots: 1

Connectors: P1

Shared memory: None

VXI busses: None

C-size compatibility: Requires E1403C

Instrument Drivers

See the Agilent Technologies Website (http://www.agilent.com/find/inst_drivers) for driver availability and downloading.

Command module

firmware: Downloadable

Command module

firmware rev: A.01

I-SCPI Win 3.1: Yes

I-SCPI Series 700: Yes

C-SCPI LynxOS: Yes

C-SCPI Series 700: Yes

Panel Drivers: Yes

VXIplug&play Win

Framework: No

VXIplug&play Win 95/NT

Framework: No

VXIplug&play HP-UX

Framework: No

Module Current

	I_{PM}	I_{DM}
+5 V:	0.2	0.01
+12 V:	0.13	0.01
-12 V:	0	0
+24 V:	0	0
-24 V:	0	0
-5.2 V:	0	0
-2 V:	0	0

Cooling/Slot

Watts/slot: 1.00

ΔP mm H₂O: 0.02

Air Flow liter/s: 0.10

Ordering Information

Description	Product No.
48-Channel Single-Ended Relay Multiplexer	E1346A
Service Manual	E1346A 0B3
Japan - Japanese Localization	E1346A ABJ
Extra terminal block for the E1346A	E1346-80001

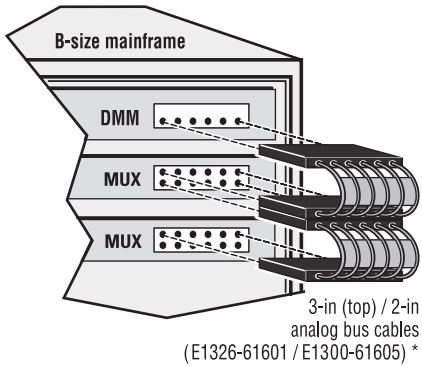

Analog bus cabling for MUX-to-MUX and MUX-to-multimeter

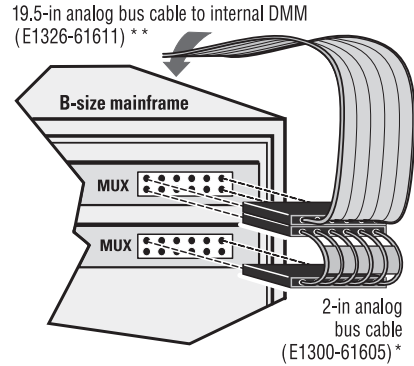

* DMM-to-MUX and MUX-to-MUX analog bus cables are provided with the purchase of the DMM and MUX modules respectively.

** 19.5-in analog bus cable is provided with purchase of E1300/01B Series B mainframe with internal DMM option.

Analog bus cabling for MUX-to-MUX and MUX-to-multimeter

E1346A Circuit Diagram

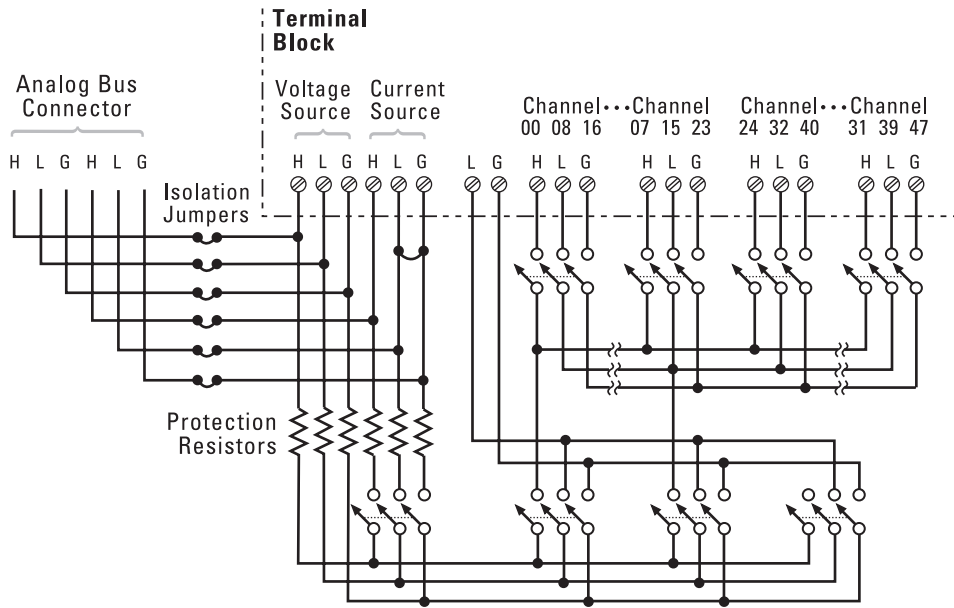

Related Literature

2000 Test System and VXI Catalog CD-ROM,
Agilent Pub. No. 5980-0308E (detailed specifications for VXI products)

2000 Test System and VXI Catalog,
Agilent Pub. No. 5980-0307E (overview of VXI products)

1998 Test System and VXI Products Data Book,
Agilent Pub. No. 5966-2812E

Online

Internet access for Agilent product information, services and support
www.agilent.com/find/tmdir

VXI product information
www.agilent.com/find/vxi

Defense Electronics Applications
www.agilent.com/find/defense_ATE

Agilent Technologies VXI Channel Partners
www.agilent.com/find/vxichanpart

Agilent Technologies' HP VEE Application Website
www.agilent.com/find/vee

Agilent Technologies Data Acquisition and Control Website
www.agilent.com/find/data_acq

Agilent Technologies Instrument Driver Downloads
www.agilent.com/find/inst_drivers

Agilent Technologies Electronics Manufacturing Test Solutions
www.agilent.com/go/manufacturing

Get assistance with all your test and measurement needs at
www.agilent.com/find/assist
or check your local phone book for the Agilent office
near you.

Agilent Technologies' test and measurement service/support commitment

Agilent strives to maximize the value our test and measurement products give you, while minimizing your risk and service/support problems. We work to ensure that each product is realistically described in the literature, meets its stated performance and functionality, has a clearly stated global warranty, and is supported at least five years beyond its production life. Our extensive self-help tools include many online resources (www.agilent.com).

Experienced Agilent test engineers throughout the world offer practical recommendations for product evaluation and selection. After you purchase an Agilent product, they can provide no-charge assistance with operation verification and basic measurement setups for advertised capabilities. To enhance the features, performance, and flexibility of your test and measurement products—and to help you solve application challenges—Agilent offers free or extra-cost product options and upgrades, and sell expert engineering, calibration, and other consulting services.

Phone or Fax

United States:
(tel) 1 800 829 4444

Canada:
(tel) 1 877 894 4414
(fax) (905) 282 6495

China:
(tel) 800 810 0189
(fax) 800 820 2816

Europe:
(tel) (31 20) 547 2323
(fax) (31 20) 547 2390

Japan:
(tel) (81) 426 56 7832
(fax) (81) 426 56 7840

Korea:
(tel) (82 2) 2004 5004
(fax) (82 2) 2004 5115

Latin America:
(tel) (305) 269 7500
(fax) (305) 269 7599

Taiwan:
(tel) 0800 047 866
(fax) 0800 286 331

Other Asia Pacific Countries:
(tel) (65) 6375 8100
(fax) (65) 6836 0252
(e-mail) tm_asia@agilent.com

Data Subject to Change
© Agilent Technologies, Inc. 2000
Printed in the U.S.A. May 1, 2004
5965-5602E