

# Agilent N2216A VXI/SCSI Interface Module with Optional Data Disks

Product Overview

Fast Data Recording for  
VXI Applications



- On-line recording of digitized signals
- Fast, continuous throughput to disk
- Low voltage differential SCSI interface
- Optional internal 50 GB or dual 50 GB hard drives
- > 30 MB/s data transfer rate to dual internal drives



**Agilent Technologies**  
Innovating the HP Way

### Capture high-speed signals directly from VXI digitizers

This C-size 2-slot VXI module is a high-speed dual SCSI interface with optional internal disks that is optimized for online recording of digital data to disk. It is ideal in a variety of data capture applications, including both dynamic and static signal acquisition. It finds applications in transient signal analysis, in acoustic and mechanical measurements, as well as electronic surveillance.

### Available in three configurations

The standard configuration consists of a dual low voltage differential/single-ended SCSI interface and is intended for applications using external SCSI storage devices. Data from the VXI backplane or local bus can be transferred directly to the external device without involving the VXI Slot 0 Controller.

The two optional configurations provide a single 50 GB internal disk or two 50 GB internal disks. These

disks provide a compact high-speed solution for on-line recording. The SCSI interface can still be used for external readback or disk backup with external SCSI DAT tape drives.

### Sustained data throughput to internal disks at 30 Mbytes/sec

There is no need to accept gaps or missing samples in your high-speed transient digital data capture applications. Using the VXI local bus, data can be transferred from VXI ADC modules to the dual disk N2216A (Option 002) at a real time, sustained rate of more than 30 Mbytes/sec without losing a single byte of data. With over 100 GB of disc storage, data can be written to the disc at this rate for over 55 minutes.

### Simultaneously monitor data while recording to disk

In cases where it is also necessary to monitor the local bus data as it is being written to disk, some (or all) of the data can be transferred to the VXI bus for monitoring by the host

computer. The effect of monitoring the data on the overall local bus transfer rate is very small; however, there is a 2 MB/sec limit on the data rate of the monitored data (using D16 transfers to shared memory).

Consequently, if the monitoring data rate doesn't exceed the shared memory rate, then the effect of data monitoring on the data recording rate to disk is not significant.

The amount of data that can be monitored is dependent upon the amount of shared memory available.

### Connect external SCSI devices for fast data export

In other applications, data can also be transferred from A/D modules via the local bus to external fast wide differential SCSI devices at the rate of 15 Mbytes/sec on each of the two SCSI interfaces, simultaneously.

Figure 1: Agilent N2216A block diagram

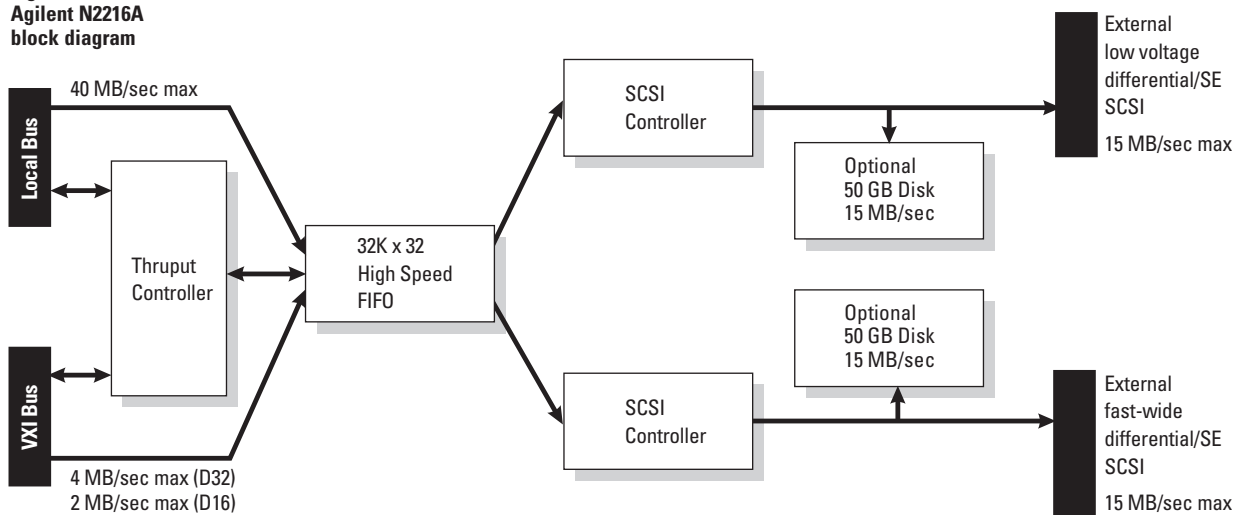

## Backup internal disk data

In the N2216A dual disk configuration (Option 002), on-line data can be written to one disc while the host computer starts backing up the second disk to an external DAT drive using the second SCSI interface (requires a cable connection between the DAT SCSI interface and the N2216A front panel connector).

If the N2216A module is not busy writing on-line data then data stored on the optional internal disks can also be backed up using the host computer by transferring the data via the VXI bus.

## Use either local bus or VXI bus data transfers

If you use VXI input modules without local bus support, data can be transferred to the SCSI module over the VXI backplane. These transfers can take place at a maximum rate of 5 Mbytes/sec (D32). For example, nine E1413C 64-Channel modules can be simultaneously writing data to the N2216A providing 576 channels scanned every 1 ms, without losing any samples.

One can also monitor data while recording it to the N2216A optional disk when local bus transfers are not involved. In this case the data is being transferred via the VXI bus to both the disk and shared memory. If the amount of data monitored is small compared to the overall amount

of data being written to disk, then the throughput rate to disk is not significantly compromised.

If all of the data is being monitored then the overall effect of monitoring while recording is a factor of two in performance. This factor of two in performance arises because the same bus is being used to transfer the data to disk as well as sending the data to shared memory for monitoring by the host.

## Use both local and VXI bus data transfers simultaneously

The N2216A can also simultaneously acquire data from both local bus modules and interleave this data stream with modules that only use the VXI bus for data transfers. An example would include a measurement situation where several E1432A (16ch 51.2KHz Digitizer) modules sending their data over the Local Bus are mixed with several E1413C (64ch Scanning A/D) modules producing data on the VXI bus. Data monitoring can also take place in these mixed local bus / VXI bus data recording sessions.

## Replace analog tape recorders in many applications

Analog tape recorders have traditionally been used to record signals so that different data analysis processes can be performed off-line, on the same data or simply to archive raw data for some future use.

Writing digitized data to disk provides more dynamic range than that available on analog tape recorders. Tape recorders (both analog and digital) are serial devices which requires the tape

to be rewound each time the data is to be reused. Recording the data on the N2216A optional internal disks provides rapid, random access to any segment of the data. The data can also be backed up to external DAT tape for long term archival storage.

## Comprehensive software support

This VXI/SCSI interface module is a message based VXI module with a Plug&Play driver and a SCPI interpreter. This allows software packages like HP or Agilent VEE an easy way to setup the N2216A module.

This module's command set allows the user a relatively simple, straight forward interface for programming the module. The complexity of managing the data flow from multiple VXI input modules to multiple disks has been reduced to typically less than a dozen SCPI commands with parameters. This programming command set manages the data transfer for applications using external SCSI devices or the optional internal 50 GB hard drives

## Additional software support

The module is also supported by a set of C example programs for use by an embedded VXI host computer (HP-UX or MS Windows®), a host computer connection via the MXI interface or Firewire (IEEE-1394).

For applications needing to manage reading and writing of multiple files on the disk(s), a LIF file system software package is available. Two versions of the LIF file system are available, one is a shared library for HP-UX and one is for MS Windows in the form of a DLL (dynamic link library).

## Accessories available

The following cables are available for connecting external SCSI devices.

Low voltage differential/single-ended cable with 68 pin connectors.

C2911A	Cable, 0.9 Meter
C2924A	Cable, 2.5 Meter

## Summary specifications

See Technical Data Sheet for a complete list of specifications.

## Ordering information

<b>Agilent N2216A</b>	VXI/SCSI Interface Module
<b>Opt 001</b>	Add one internal 50 GB hard drive
<b>Opt 002</b>	Add two internal 50 GB hard drives
<b>Opt 0B0</b>	Delete manual set
<b>Opt 0B1</b>	Add manual set
<b>Opt AUC</b>	Factory installed with DAC <i>Express</i> system
<b>Opt W01</b>	Convert to one year on-site warranty

## Agilent Technologies' Test and Measurement Support, Services, and Assistance

Agilent Technologies aims to maximize the value you receive, while minimizing your risk and problems. We strive to ensure that you get the test and measurement capabilities you paid for and obtain the support you need. Our extensive support resources and services can help you choose the right Agilent products for your applications and apply them successfully. Every instrument and system we sell has a global warranty. Support is available for at least five years beyond the production life of the product. Two concepts underlie Agilent's overall support policy: "Our Promise" and "Your Advantage."

### Our Promise

Our Promise means your Agilent test and measurement equipment will meet its advertised performance and functionality. When you are choosing new equipment, we will help you with product information, including realistic performance specifications and practical recommendations from experienced test engineers. When you use Agilent equipment, we can verify that it works properly, help with product operation, and provide basic measurement assistance for the use of specified capabilities, at no extra cost upon request. Many self-help tools are available.

### Your Advantage

Your Advantage means that Agilent offers a wide range of additional expert test and measurement services, which you can purchase according to your unique technical and business needs. Solve problems efficiently and gain a competitive edge by contracting with us for calibration, extra-cost upgrades, out-of-warranty repairs, and on-site education and training, as well as design, system integration, project management, and other professional engineering services. Experienced Agilent engineers and technicians worldwide can help you maximize your productivity, optimize the return on investment of your Agilent instruments and systems, and obtain dependable measurement accuracy for the life of those products.

### For More Assistance with Your Test & Measurement Needs go to

[www.agilent.com/find/assist](http://www.agilent.com/find/assist)

Or contact the test and measurement experts at Agilent Technologies  
(During normal business hours)

**United States:**  
(tel) 1 800 452 4844

**Latin America:**  
(tel) (305) 267 4245  
(fax) (305) 267 4286

**Canada:**  
(tel) 1 877 894 4414  
(fax) (905) 206 4120

**Australia:**  
(tel) 1 800 629 485  
(fax) (61 3) 9272 0749

**Europe:**  
(tel) (31 20) 547 2323  
(fax) (31 20) 547 2390

**New Zealand:**  
(tel) 0 800 738 378  
(fax) 64 4 495 8950

**Japan:**  
(tel) (81) 426 56 7832  
(fax) (81) 426 56 7840

**Asia Pacific:**  
(tel) (852) 3197 7777  
(fax) (852) 2506 9284

Product specifications and descriptions in this document subject to change without notice.  
Copyright © 2000 Agilent Technologies  
Printed in U.S.A. 5/00  
5980-0728E



**Agilent Technologies**

Innovating the HP Way