

# Agilent 35181M

## Storage Drawer, 5.25 inch

Data Sheet

### Conveniently store miscellaneous items

The Agilent 35181M storage drawer provides storage space for miscellaneous items such as tools, manuals, probes, or cables.

### Features

- Provides a 133 mm (5.25 in) storage space
- Attractive quartz gray color
- All mounting hardware included

### Specifications

- Material: Cold-rolled steel
- Weight: 8.16 kg (18 lbs)
- Color: Quartz gray
- Length: 521 mm (20.5 in)
- Depth: 133 mm (5.25 in)
- Width: 425 mm (16.73 in)

### Installation

Attach clip nuts at the desired location on the columns and secure slides with screws.

Tools required for installation:

- Torx T15 screwdriver

### What you get in the box

- Drawer with slides attached
- All mounting hardware
- Installation instructions

### What changed

Replaces: 35181G

- Color changed from parchment white to quartz gray

### Compatibility

The 35181M can be used with:

- 1181B – Agilent testmobile instrument cart
- E3660B – Agilent 1.1 m rack
- E7590A – Agilent 1.3 m rack
- E3661B – Agilent 1.6 m rack
- E3662B – Agilent 2.0 m rack

### Related Products

An additional drawer size is available:

- 35181J – Agilent storage drawer, 3.5 inch

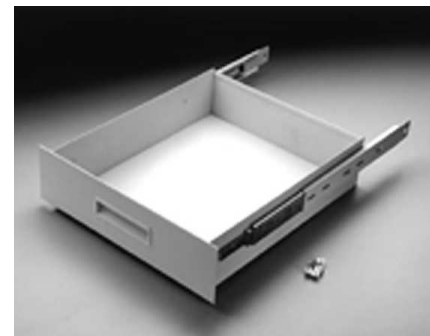

### Warranty

Three-year replacement

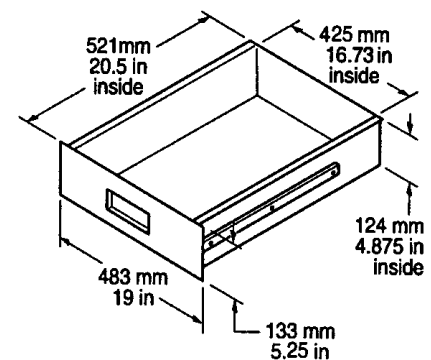

Agilent Technologies

**Agilent Technologies' Test and Measurement Support, Services, and Assistance**

Agilent Technologies aims to maximize the value you receive, while minimizing your risk and problems. We strive to ensure that you get the test and measurement capabilities you paid for and obtain the support you need. Our extensive support resources and services can help you choose the right Agilent products for your applications and apply them successfully. Every instrument and system we sell has a global warranty. Support is available for at least five years beyond the production life of the product. Two concepts underlie Agilent's overall support policy: "Our Promise" and "Your Advantage."

**Our Promise**

"Our Promise" means your Agilent test and measurement equipment will meet its advertised performance and functionality. When you are choosing new equipment, we will help you with product information, including realistic performance specifications and practical recommendations from experienced test engineers. When

you use Agilent equipment, we can verify that it works properly, help with product operation, and provide basic measurement assistance for the use of specified capabilities, at no extra cost upon request. Many self-help tools are available.

**Your Advantage**

"Your Advantage" means that Agilent offers a wide range of additional expert test and measurement services, which you can purchase according to your unique technical and business needs. Solve problems efficiently and gain a competitive edge by contracting with us for calibration, extra-cost upgrades, out-of-warranty repairs, and on-site education and training, as well as design, system integration, project management, and other professional services. Experienced Agilent engineers and technicians worldwide can help you maximize your productivity, optimize the return on investment of your Agilent instruments and systems, and obtain dependable measurement accuracy for the life of those products.

By internet, phone, or fax, get assistance with all your test and measurement needs.

**Online Assistance**

[www.agilent.com/find/assist](http://www.agilent.com/find/assist)

**Phone or Fax**

United States:

(tel) 1 800 452 4844

Canada:

(tel) 1 877 894 4414

(fax) (905) 282 6495

Europe:

(tel) (31 20) 547 2323

(fax) (31 20) 547 2390

Japan:

(tel) (81) 426 56 7832

(fax) (81) 426 56 7840

Latin America:

(tel) (305) 269 7500

(fax) (305) 269 7599

Australia:

(tel) 1 800 629 485

(fax) (61 3) 9210 5947

New Zealand:

(tel) 0 800 738 378

(fax) (64 4) 495 8950

Asia Pacific:

(tel) (852) 3197 7777

(fax) (852) 2506 9284

Product specifications and descriptions in this document subject to change without notice.

Copyright © 2001 Agilent Technologies

Printed in U.S.A. May 1, 2001

5988-2774EN



**Agilent Technologies**