

MPC 8XX Emulation and Analysis Solutions for Motorola Microprocessors

Product Overview
Debug and Integrate Real-Time
Embedded Systems

Quickly and accurately determine the root cause of your team's most difficult hardware, software, and system integration problems with Agilent's powerful emulation and logic analysis solutions.

Agilent's emulation and analysis solutions for the Motorola MPC 8XX microprocessors combine the

powerful tools of run control, code download, debugger connections, and logic analysis for a complete, scalable system debug environment.

With a scalable solution from Agilent, design team members can customize Agilent's product offerings to meet their unique requirements. Solutions range from emulation probes combined with the industry's leading debuggers to emulation with real-time trace to solve today's most complex Motorola MPC 8XX design problems. Agilent's solutions are designed to meet your needs today and protect your investment as your needs change in the future.

With logic analysis providing timing and state analysis, you can monitor microprocessor activity in relation to other important system signals such as a PCI bus, other microprocessors, or I/O devices. Traditional emulation systems don't allow you to time-correlate events across your entire system using timing, analog, and state analysis for your most difficult integration problems.

The logic analyzer is nonintrusive, allowing you to run your target system at full speed. A system trace, up to 2 M deep, can be combined with complex triggering to find the toughest problems. The microprocessor instruction set execution can be correlated to the high-level source code with the Agilent source correlation tool set.

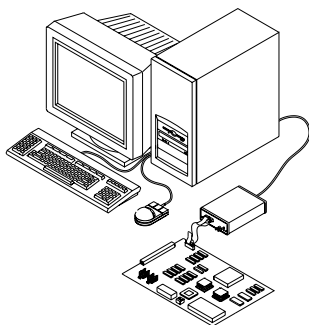

JTAG Emulation

- Verify Interrupt Routines
- Debug Assembly Code
- Optimize Code

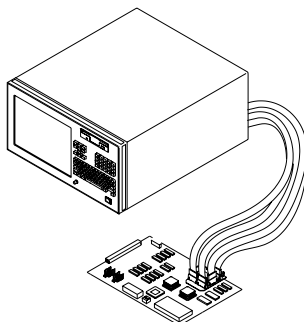

Logic Analysis Solution

- Perform Basic Signal Measurements
- Profile Hardware Operation
- Verify Signal Integrity
- Verify Conformance to Specifications
- Exercise Microprocessor and Other Hardware
- Debug Boot Code

Emulation and Analysis Solutions for the Design Team

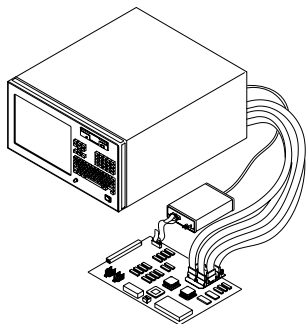

Emulation Solution with Real-Time Trace

- Debug Hardware/Software Interaction
- Profile Hardware/Software Interaction
- Optimize System Performance
- Perform System Test



Agilent Technologies
Innovating the HP Way

Agilent Scalable Solutions

Agilent emulation and logic analysis solutions are scalable for each member of the digital design team. The following are three typical configurations for firmware/software

debug, hardware debug, and system integration.

Components of these solutions include a logic analyzer, emulation probe/module, analysis probe,

inverse assembler, source correlation tool set, and system performance analysis tool set. Information on each of these components is included in this document.

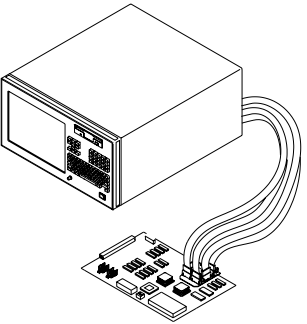
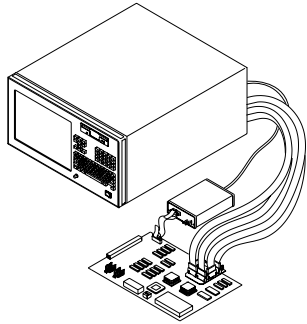
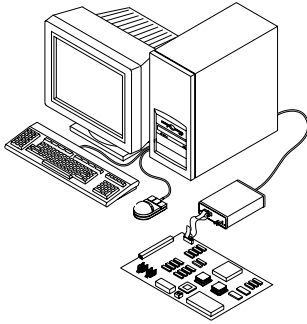

System Features

BDM Emulation

- Microprocessor run control on your target system
- Debugger connection

Emulation Solution with Real-Time Trace

- Microprocessor run control on your target system
- Debugger connection
- Real-time logic analysis trace solution:
 - Assembly level trace
 - Source code trace
- BGA probing solution

Logic Analysis Solution

- Real-time logic analysis trace solution:
 - Assembly level trace
 - BGA probing solution

System Components and Functionality

- MPC 8XX Emulation Probe: (see p. 3)
 - Exceptional download speed and single stepping
 - View and modify memory, view and modify register on your target system or evaluation board from the debugger interface
- Connection to industry-leading debuggers from GreenHills Microtec, SDS, and Wind River

- Agilent 16700A Series Logic Analysis System:
 - Capture and analyze code flow and data flow without halting the target system
 - Time-correlate analog, timing, and state events across your entire system
 - Monitor microprocessor activity in relation to system buses, other microprocessors, or I/O devices
- MPC 860/821 Analysis Probe: (see p. 10)
 - Connect to target using 357 pin BGA probing solution
 - Disassemble trace listing into MPC 860/821 mnemonics
- Integrated Emulation Module: (see p. 3)
 - Exceptional download speed and single-stepping
 - View and modify memory, view and modify registers on your target system or evaluation board from the debugger interface
 - Connect to industry-leading debugger from GreenHills, ARM, and Wind River.
- Agilent Source Correlation Tool Set: (see p. 9)
 - Time-correlate acquired logic analysis trace to high-level source code
 - Step through in assembly or high-level code

- Agilent 16700A Series Logic Analysis System:
 - Capture and analyze code flow and data flow without halting the target system
 - Time-correlate analog, timing, and state events across your entire system
 - Monitor microprocessor activity in relation to system buses, other microprocessors, or I/O devices
- MPC 860/821 Analysis Probe: (see p. 10)
 - Connect to target using 357 pin BGA probing solution
 - Disassemble trace listing into MPC 860/821 mnemonics

Microprocessor	Package Type	Microprocessor Clock Speed	BDM Emulation	Emulation Solution with Real-Time Trace	Logic Analysis Solution
MPC 860/821 • DC, DE, DH, DP, DT, EN, MH, SAR, T, P	357 BGA	Up to 50 MHz	X	X	X
MPC 801	256 BGA	Up to 50 MHz	X		
MPC 850, MPC 855		256 BGA	Up to 50 MHz	X	

Table 1: Emulation and Analysis Solutions for Motorola MPC 8XX Microprocessor

Emulation Probe and Module

The emulation probe and module provide the same functionality. The emulation probe is a stand-alone product, as shown in figure 1. The emulation module is an integrated plug-in for the Agilent 16700A Series logic analysis systems.

The emulation probe and module have been improved to provide the exceptional download speed and single stepping. These improvements include:

- 32 bit microprocessor
- 100 Base TX LAN
- New scan-chain controller

Both the probe and module help you debug your code by providing run control, code download, and memory/register display and modification. You can control program execution through single stepping, run/break, and set/modify break-point. You can also run code at full speed in the target. Agilent's new emulation probe and modules allow you to complete these tasks more quickly so you can bring your products to market sooner.

An industry leading debugger can be used to control both the emulation probe and module. Alternatively, they can be controlled by the emulation control interface provided with the logic analyzer. These interfaces are described on page 4.

The Agilent emulation probe and module can be controlled over your local area network (LAN) by the debugger and connect to your target through a 16-pin Berg style connector, as shown in figure 5.

Unlike traditional emulators, the emulation probes and modules provide more stable operation by accessing only the debug pins of the microprocessor. You don't need a serial port on your target system to download code. Unlike ROM monitors, they don't require user memory.

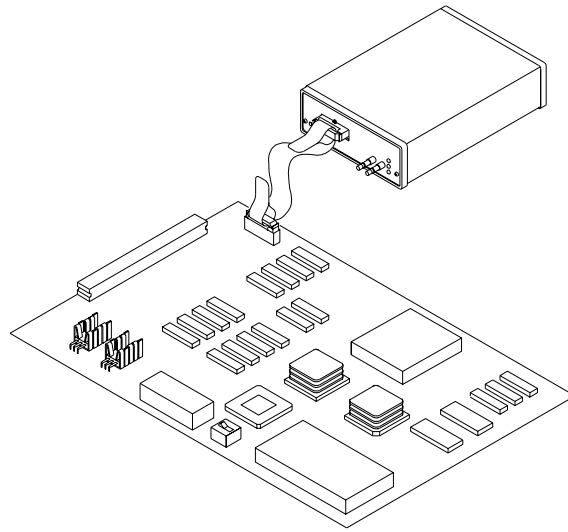

Figure 1: Standalone Agilent Emulation Probe

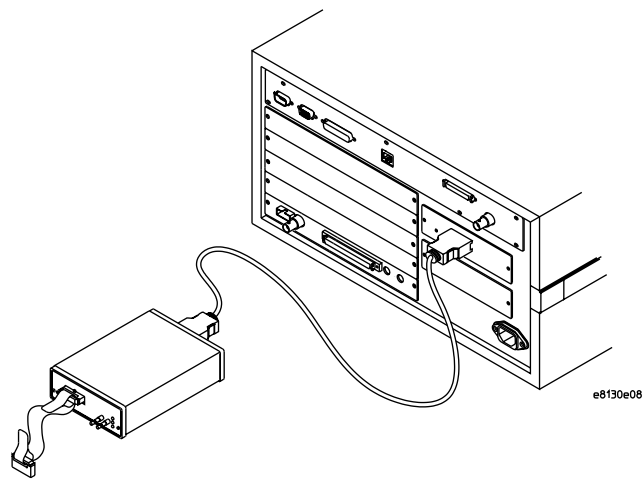

Figure 2: Agilent 16702 Logic Analysis System with Integrated Emulation Module

Debugger Interface

Industry-leading debuggers can control the emulation probe and emulation module. You can set breakpoints, single-step through code, examine variables, and modify source code variables from the high-level source code debugger interface.

Debugger interfaces must be ordered directly from the debugger vendor.

Debugger Connections

GreenHills Software, Inc.
 30 West Sola Street
 Santa Barbara, CA 93101 USA
 805-965-6044
<http://www.ghs.com>

Microtec, A Mentor Graphics Company
 880 Ridder Park Drive
 San Jose, CA 95131 USA
 Phone: (800) 950-5554
 Phone: (408) 487-7000
<http://www.mentor.com/microtec>

Diab-SDS
 323 Vintage Park Drive
 Foster City, CA 94404 USA
 Phone: 630-724-2520
<http://www.diabsda.com>

Wind River Systems
 500 WindRiver Way
 Alameda, CA 94501 USA
 510-748-4100
<http://www.windriver.com>

Please check with your local Agilent sales office or visit our web site at <http://www.agilent.com/find/las-data> for the current list of validated debugger connections.

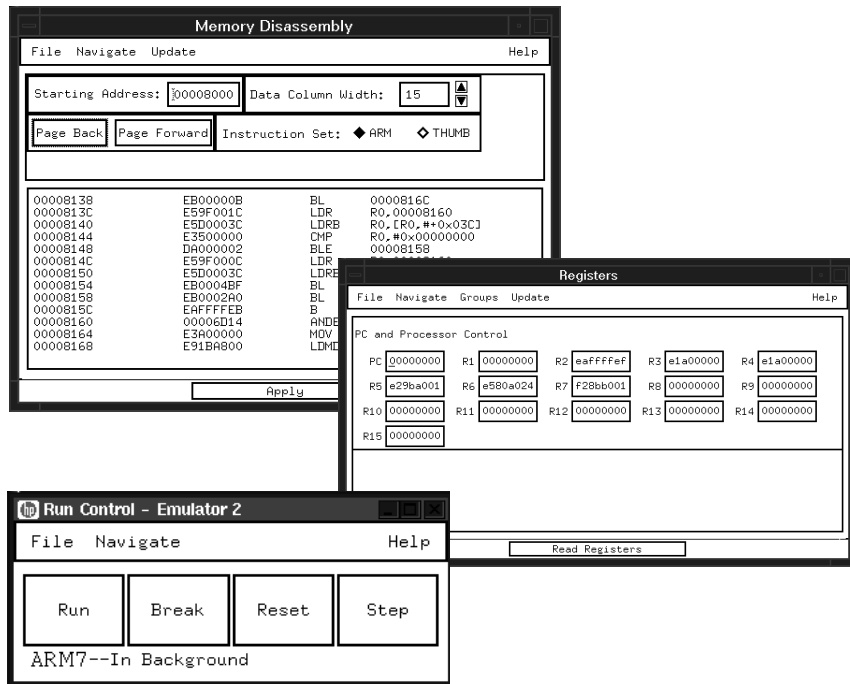

Figure 3. Emulation Control Interface

Emulation Control Interface

The emulation module integrated into the logic analysis system can be controlled directly by the emulation control interface. You can easily display and modify contents of microprocessor registers, system memory, and I/O. You can also view memory code segments disassembled into familiar ARM or Thumb assembly instructions. Download code into RAM or Flash ROM.

From the run control window you can instruct the microprocessor to run, break, reset, or single-step. You also can choose whether the memory, I/O, and register displays are updated for breaks and single steps.

Writing command files that set up registers, memory, and I/O in your system is easy with the command language. Once the procedure is written, save it on the logic analyzer hard disk. When you want to initialize your hardware system to a particular state, simply recall and execute the command file. Unlike the debugger interface, the emulation control interface does not reference back to the high-level source code.

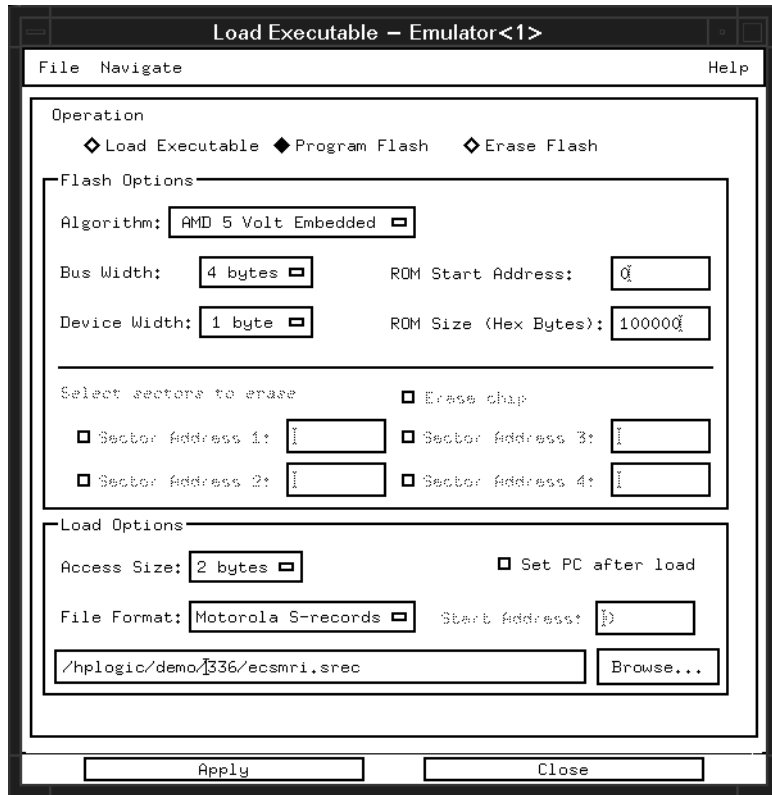

Figure 4: Flash Programming from Emulation Control Interface

Flash Support

Agilent emulation modules and probes support flash download. AMD 12V, AMD 5V, Intel Auto, and Intel Quickpulse (AMD Flashwrite) are supported.

Contact GreenHills, Microtec, or Diab SDS for flash algorithms supported by their debugger interface.

Emulation Module and Probe Migration

Agilent protects your current investment by providing a migration path for the emulation modules and probes as your needs change. To move from one processor family to another, simply order a migration kit for the emulation module or probe, which will provide all the necessary hardware, firmware, and cables to support your new processor family at a fraction of the cost of a new system.

This same migration path works for the emulation probes or emulation modules. Migration is available for those processors in the E5900B Series

Emulation Module Triggering Integration with Logic Analyzer

With the emulation module, use the powerful triggering of the Agilent 16700A Series logic analysis systems to halt on events such as microprocessor activity, system buses, or other external events. The emulation module also can trigger the logic analyzer when a breakpoint is hit. This provides powerful event correlation between the debugger interface environment and the logic analyzer

Emulation Probe and Module Target Connection Information

The emulation probe and module can be used directly with the MPC 860/821 analysis probe. When used together, the 10-pin connector is not necessary because the debug port pins are accessed directly through the analysis probe.

If the analysis probe is not used, a 10-pin Berg style connector must be designed into the target system. Most evaluation boards already have the 10-pin connector with the standard pin-out. Refer to figure 5 for pin-out information.

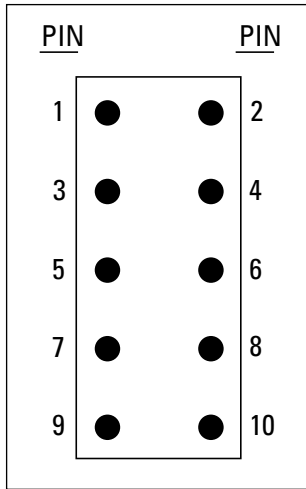

Figure 5: Header Pin Assignment

Probe Pin #	Signal	MPC860/821 Pin #
1	VFLS0	H2
2	*SRESET ³	P2
3	GND	
4	DSCK ¹	H16
5	GND	
6	VFLS1	J3
7	*HRESET ³	N4
8	DSD1 ¹	H17
9	VDD ²	
10	DSD0 ¹	G17

1 Do not series terminate DSCK, DSD1, or DSD0. All of the signal termination is done by the emulation probe and module.

2 VDD should be one of the four internal power pins : A8,M1,W8, H19

3 *SRESET and *HRESET will be driven low at times through a 100 Ohm resistor. A conflict may arise if *SRESET and/or *HRESET are driven high by the target.

Table 2: Emulation Probe/Module Signal Information

Specification	Description
Microprocessor Supported	Motorola MPC 8xx (See page 2 Table 1, for versions)
Physical Connections	Ethernet RS-232-C Autosensing 10/100 Ethernet 9600 Kbaud rate
Physical Size	105 mm width x 151 mm depth x 40 mm height
Environmental	
Temperature	Operating 5°C to +40°C (+41°F to +104°F) Nonoperating -40°C to +70°C (-40°F to +158°F)
Altitude	Operating, 4,600 m (15,000 ft); Nonoperating 4,600 m, (15,000 ft)
Humidity	15% to 80% @ 40°C for 24 hours
Regulatory Compliance	
EMC	CISPR 11:1990/EN 55011:1991 Group 1, Class A
IEC 801-2:	1991/EN 50082-1:1992 4 kV CD, 8 kV AD
IEC 801-3:	1984/EN 50082-1:1992 3 V/M, (1 KHZ 80% AM, 27-1 kHz)
IEC 801-4:	1988/EN 50082-1:1992 0 Rkv Signal Lines, 1 kV Power Lines
Safety Approval	IEC 1010-1: 1990 AMD 1: 1992 UL 1244 CSA-C22.2 No. 231 (Series M-89)

Table 3: HP Emulation Probe and Module Specifications

Real-Time Trace Analysis

Real-time trace analysis consists of a physical connection to signals on the Motorola MPC 860/821 microprocessor, acquisition of relevant data, and analysis of the real-time captured bus information.

Physical connection to the microprocessor is provided by either of the

two probing alternatives listed below. With the analysis probe, a physical connection to the microprocessor is provided with a BGA probing solution. An optional AMP Mictor probing solution is also available.

Real-time trace analysis solutions are available for both probing alternatives.

These include inverse assembly, source correlation, and system performance analysis for the Motorola MPC 860/821.

For information on the data acquisition modules for the Agilent 16700A Series logic analyzers please refer to related Agilent literature on page 21

MPC 8XX Microprocessor	Supported Speed	Probing Solutions	Real-Time Trace Solutions
MPC 821 MPC 860 (DC, DE, DH, DP, DT, EN, MH, SAR, T, P) MPC 855/MPC 855T	Up to 50 MHz	Analysis Probe: <ul style="list-style-type: none"> • 357 pin BGA probing solution • Inverse assembler included • Access to all microprocessor signals for logic analysis 	Inverse Assembly: <ul style="list-style-type: none"> • Disassembly of bus information into MPC 860/821 microprocessor mnemonics • MPC 860/821 configuration files for logic analyzer
		Optional Mictor Connector Solution: <ul style="list-style-type: none"> • Mictor connectors designed in target for access to critical signals for logic analysis 	Source Correlation: <ul style="list-style-type: none"> • Time-correlation of acquired trace to high-level source code • Trigger and search through trace in high-level source code
			System Performance Analysis: <ul style="list-style-type: none"> • Statistical performance measurements on trace data • State overview, state interval, time interval, and time overview measurements

Table 4: Real-Time Trace and Probing Alternatives

Cache-on Trace

Agilent provides industry leading real-time measurements including the ability to trace while the instruction cache is enabled. Simply enable the MPC8XX show cycles and the logic analyzer will do the rest. The MPC860/821 inverse assembler has reconstruction software that will read the branch trace messages and provide a reconstructed trace of the pro-

gram flow, maintaining compatibility with source correlation. This also minimized the number of show cycles required thereby maximizing your system performance. You can also view the reconstructed program flow and other bus activity such as cache-line fills from within the same window. Simply filter out whatever information is not needed.

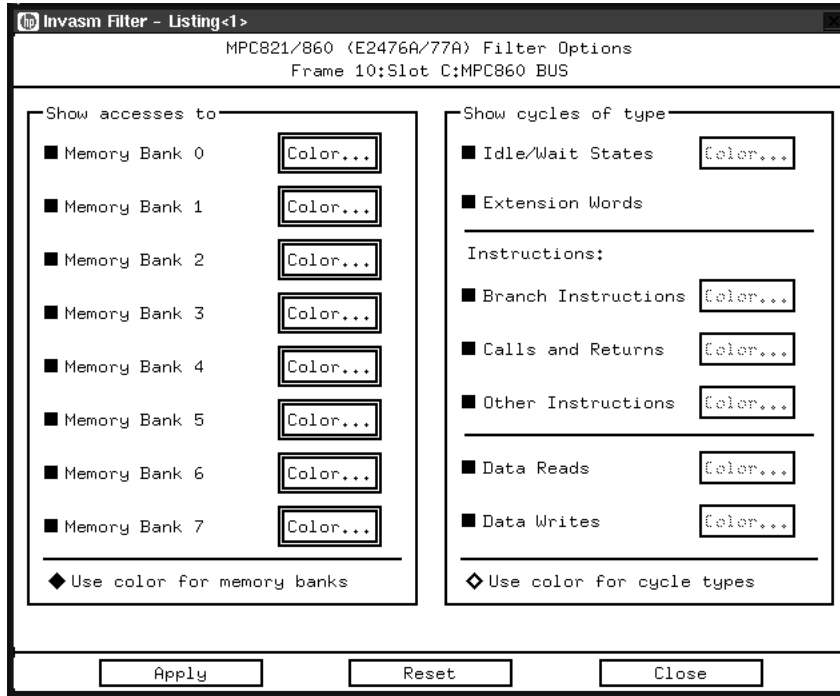

Figure 6: Inverse Assembler Filter Options

Inverse Assembler

Software provided with the analysis probe quickly configures the logic analyzer by labeling address, data, and status signals for the MPC 860/821. The software includes an inverse assembler, which gives you MPC 860/821 mnemonics in the trace listing for easy correlation between captured data and target code. The inverse assembler works with the Agilent B4620B source correlation tool set to provide time correlation between the assembly-level trace and the high-level source code.

The inverse assembler provides filters and color coding to show and/or suppress different instructions such as data reads, data writes, unexecuted prefetches, and memory map regions.

The inverse assembler has several modes of operation, depending on your microprocessor configuration. The inverse assembler provides MPC 860/821 mnemonics, but the cache must be off to see all cycles on the microprocessor. If the cache is on and

branch trace messages are enabled, a separate execution tracker reconstructs the addresses of the branch trace messages. This does not provide inverse assembly, but allows code flow measurements using the Agilent source correlation tool set.

Agilent B4620B Source Correlation Tool Set

The inverse assembler can be used with the Agilent B4620B source correlation tool set. This allows time correlation of an acquired trace to source code. The source correlation tool set uses the symbolic information provided in your object file to build a database of source files, line numbers and symbol information.

Once the logic analyzer acquires the real-time trace, you can step through the trace at assembly-code level or source-code level. You can also easily locate the cause of a problem by stepping backward to the root cause. With time-correlated analysis in both the digital and analog domains, Agilent provides powerful solutions for your most difficult hardware/software integration problems.

IEEE 695, Elf/Dwarf, and ASCII symbol files are supported.

System Correlation

With the Agilent logic analysis systems, you can time-correlate bus information from other microprocessors or bus interfaces in your target system, such as a PCI bus, with the MPC 860/821. Analysis probes are available for additional microprocessors. (Contact your local Agilent Test and Measurement sales office or visit our web site at <http://www.agilent.com/find/las-data> for more information).

Agilent B4600A System Performance Analysis Tool Set

The system performance analysis (SPA) tool set is an optional software package for the Agilent 16700A Series logic analysis systems. The SPA tool set provides such statistical performance measurements on your system

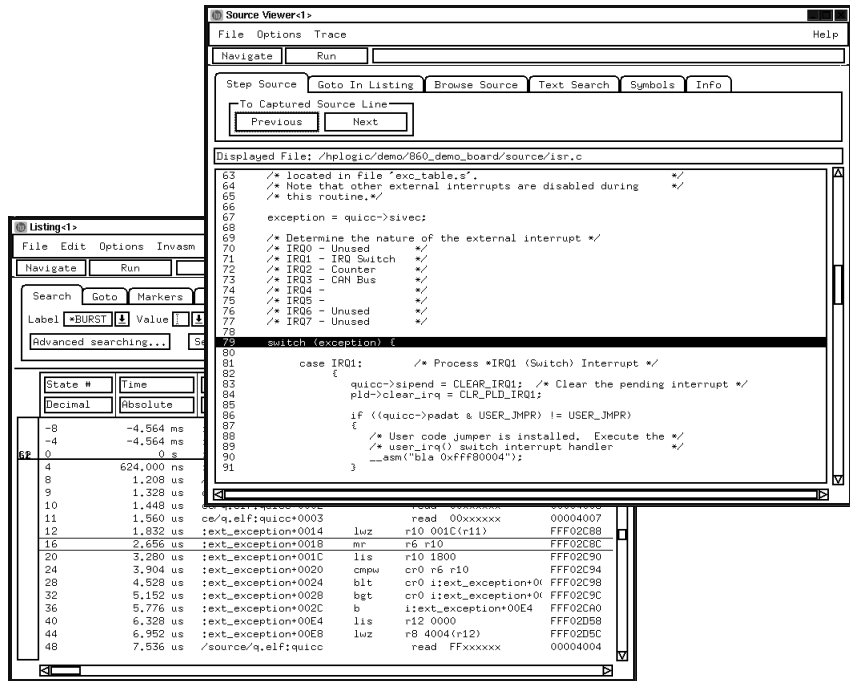

Figure 7: Inverse Assembled Trace Time-Correlated to Source Code Using the Agilent Source Correlation Tool Set

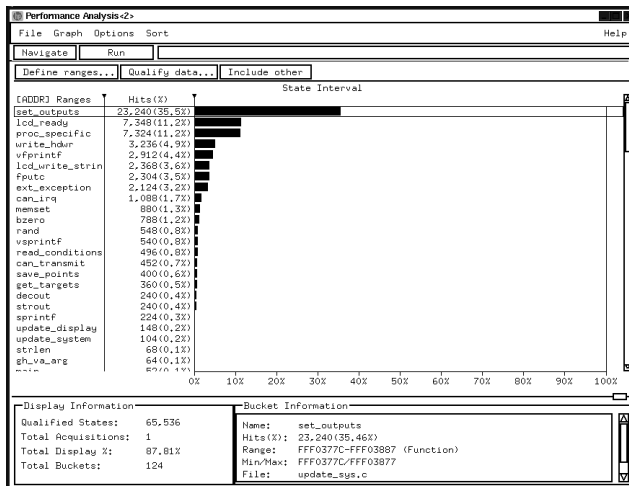

Figure 8: Statistical Performance Information from the Agilent System Performance Analysis Tool Set

as state overview, state interval, time interval, and time overview. The same symbol file used with the source correlation tool set provides symbolic support for the system performance analyzer, as shown in figure 8.

Passively Probing a Motorola MPC 860/821 BGA Target System with Agilent Technologies E5346A High-Density Termination Adapters

This product note describes how to connect a Agilent Technologies logic analyzer to the BGA package of a Motorola MPC 860/821 target system for use with an inverse assembler.

Signals required for inverse assembly are shown in the pinout information beginning on page 15 and must be routed to AMP Mictor 38 connectors for connection to the logic analyzer.

Six, 16-channel logic analyzer pods are required for inverse assembly. These six pods are connected via the Mictor connectors to three E5346A high-density termination adapters. The termination adapters are not included with the inverse assembler and must be ordered separately.

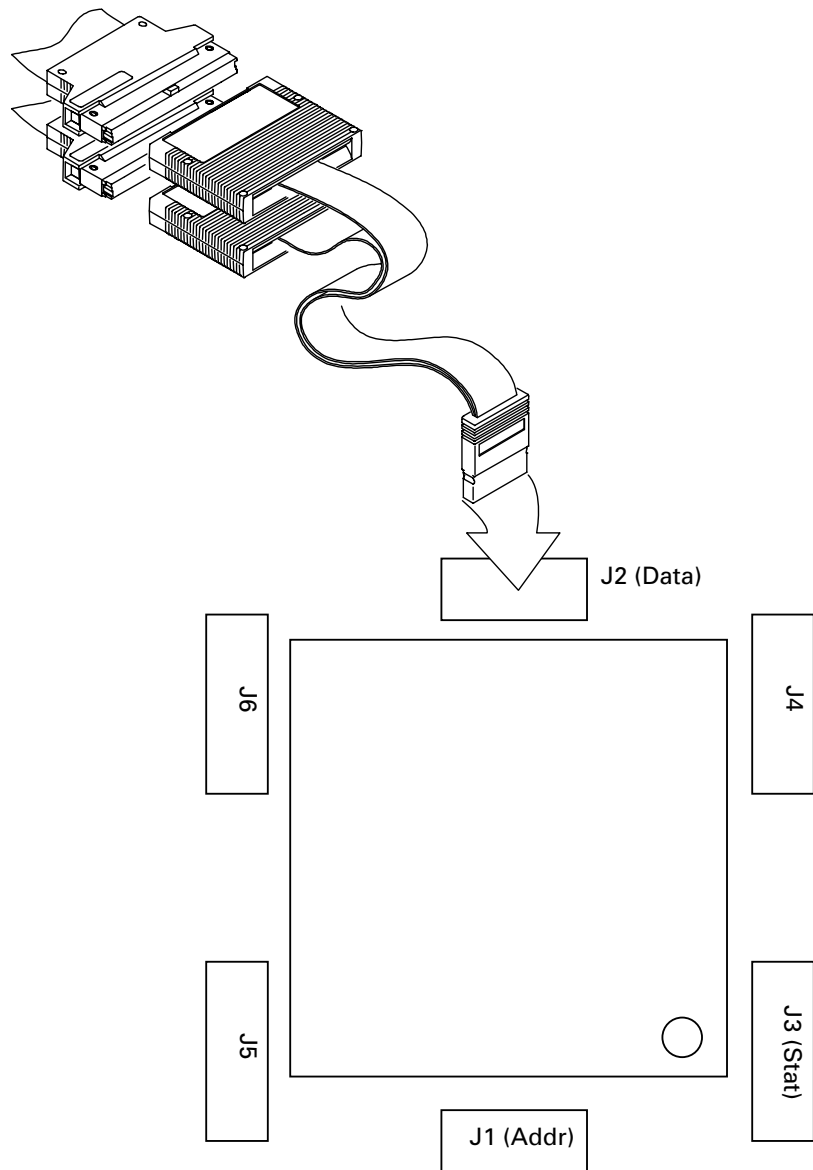

Figure 9: Connector Layout for the MPC 860/821 BGA Target

Direct Connection through E5346A High-Density Adapter Cables

The E5346A high-density adapters use a minimal amount of board space. Each high-density adapter connects to two logic analyzer pods, providing 32 channels of logic analysis per connector and access to two clock pins, as shown in figure 10.

Grounds need to be connected to pin 3 of the AMP Mictor connector. SCL, +5VDC and SDA are not to be connected to the target system (pins 1, 2, and 4 on the Mictor connector).

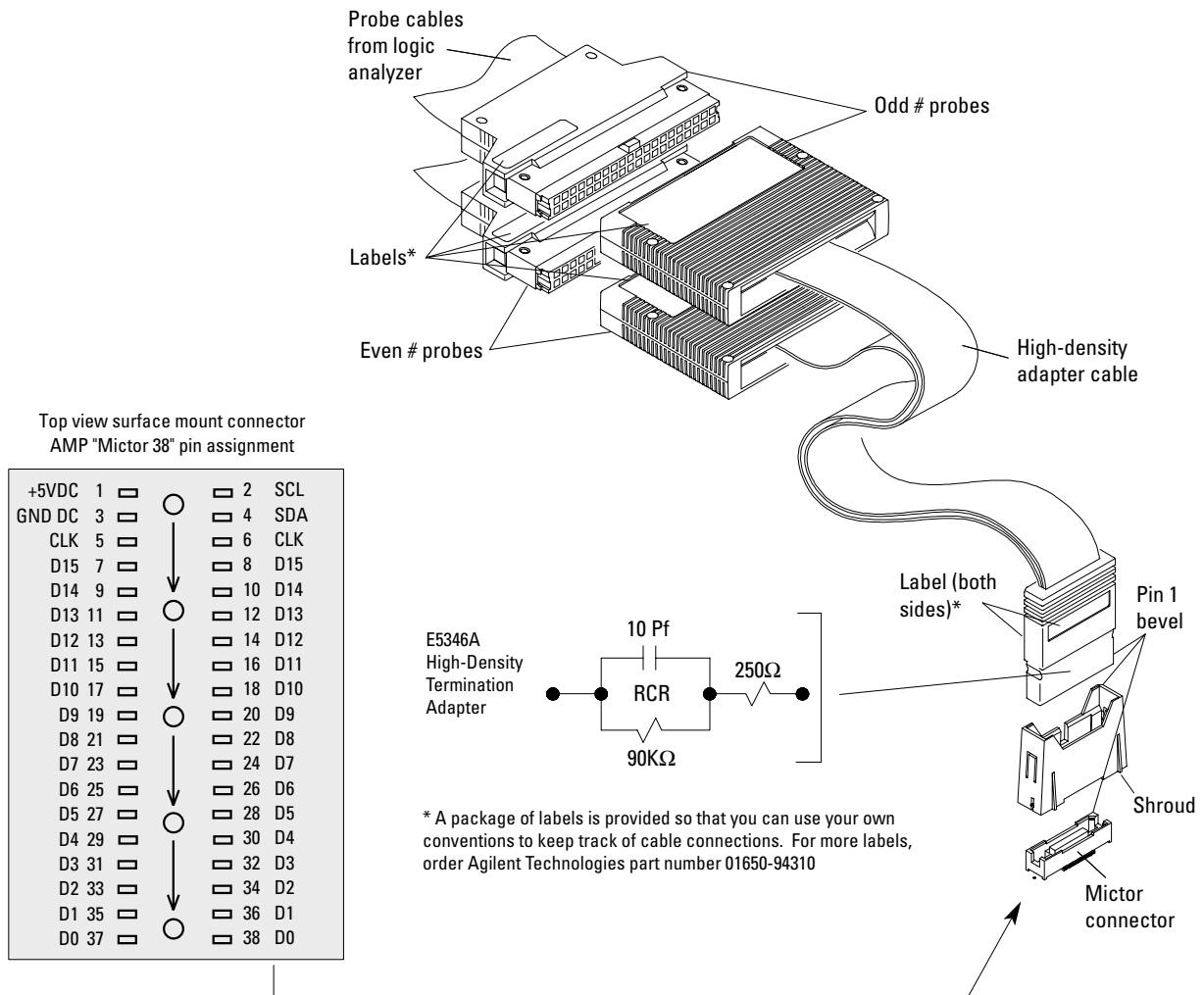

Figure 10: Agilent E5346A High-Density Termination Adapter

Termination for logic analysis is included at the probe tip of the E5346A high-density termination adapter for easy application and use. A schematic of this termination is shown in figure 11.

The AMP Mictor connector must be placed close enough to the target system so that the stub length created is less than 1/5 the T_r (bus risetime). For PC board material ($\epsilon_r=4.9$) and Z_0 in the range of $50-80\Omega$, use a propagation delay of 160 ps/inch of stub.

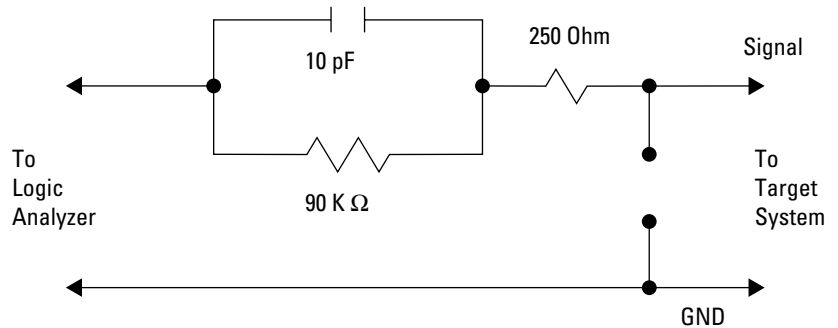

Figure 11. RC Network for Signal Termination

Three E5346A adapters and Mictor connectors are needed to probe all the required signals for inverse assembly.

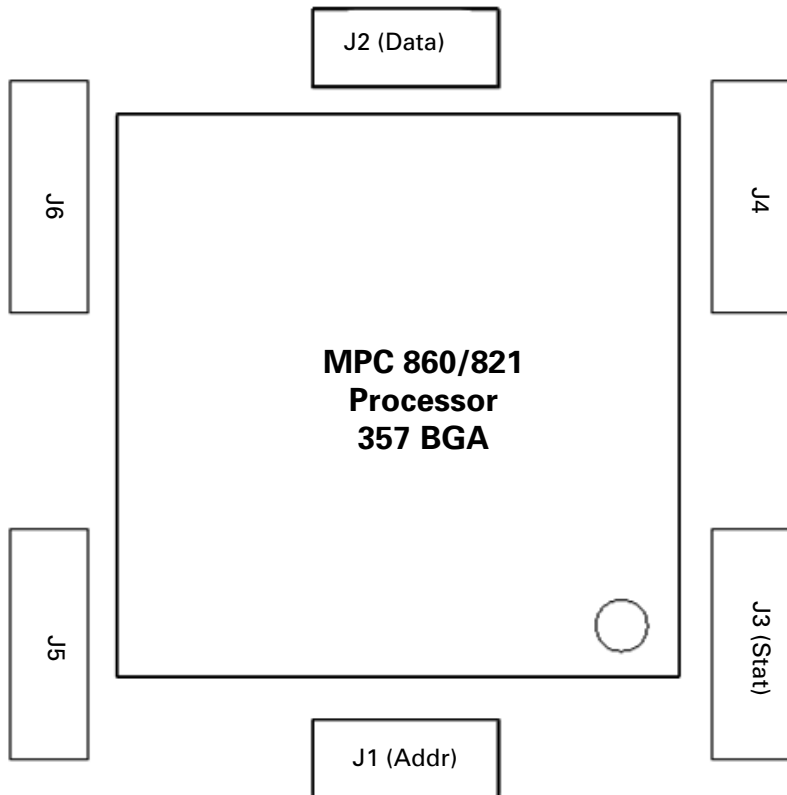

Figure 12. Mictor Connector Placement

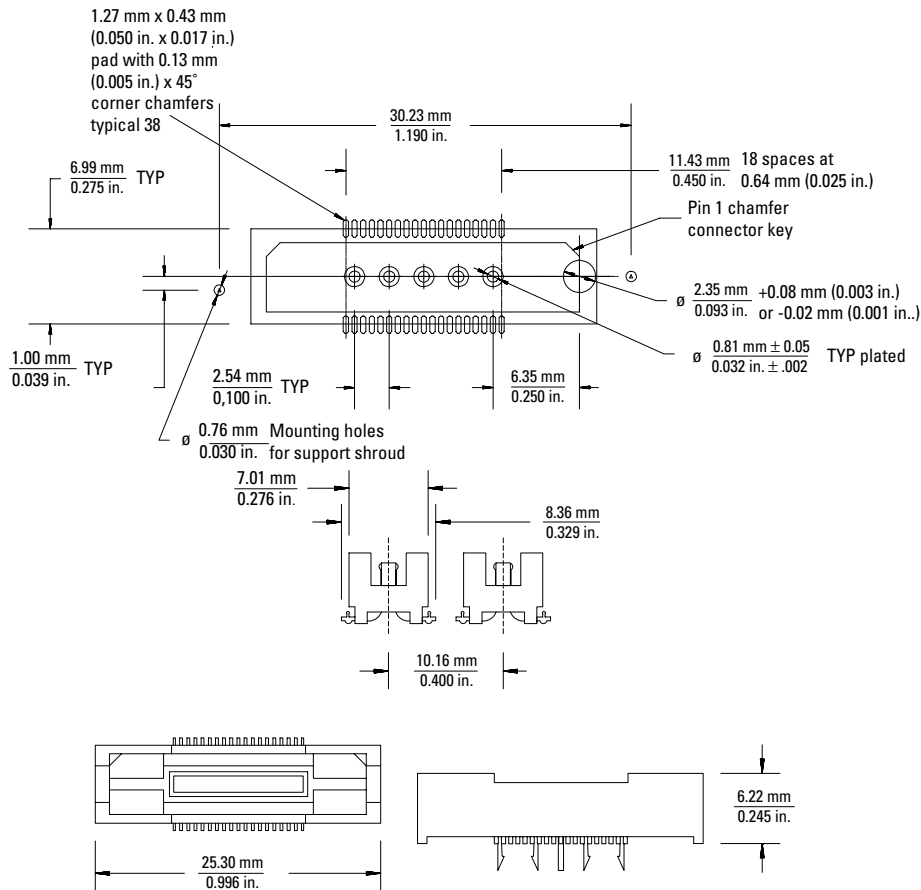

Figure 13. AMP Mictor Connector Dimensions

Mictor Connector Placement

Placing the AMP Mictor connectors as close as possible to the signal source will minimize stub length and ensure a reliable measurement. Figure 12 shows the connector layout of J1-J6. J1-J3 are required for inverse assembly. J4-J6 are optional for timing and state analysis of I/O ports.

Mictor Connector

The AMP Mictor connectors are available from AMP (PN 2-767004-2) or from Agilent (PN E5346-68701). The Agilent Mictor kit contains five AMP Mictor connectors and five support shrouds. The signals +5 V DC, SCL, and SDA are not used for probing and should not be connected to the target system, as shown in figure 10.

Support Shroud

A support shroud (Agilent E5346-44701) is recommended to provide additional strain relief between the Agilent E5346A adapter and the AMP Mictor connector, as shown in figure 13. The shroud fits around the AMP Mictor connector and requires two through-hole connections to the target board. Five shrouds are included with five AMP Mictor connectors in the E5346-68701 kit.

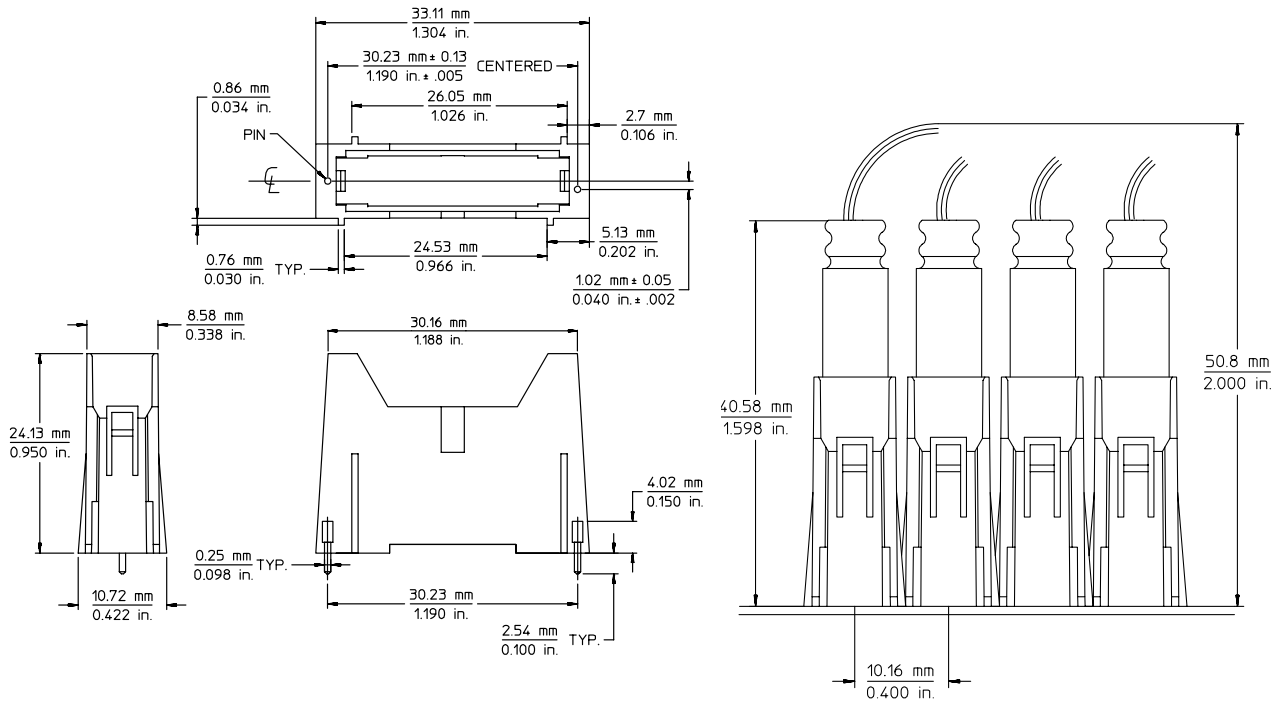

Figure 14. Support Shroud Dimensions

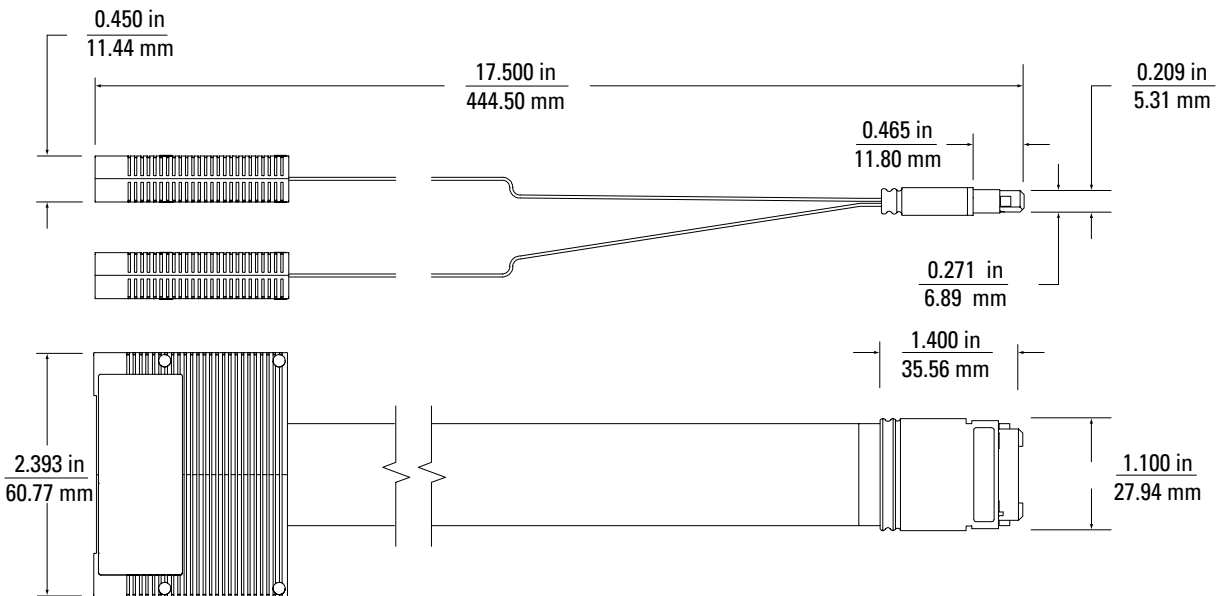

Figure 15. High-Density Termination Adapter Cable Dimensions

**Pin-Out Information on
Required Signals for Inverse
Assembly**

This table describes the three Mictor 38 connectors necessary for compatibility with the inverse assembler and the E5346A high-density termination adapter cables. This is intended to be a guide for placing probing connectors on a target system.

For the inverse assembler, the J1, J2, and J3 connectors listed below must be connected through the three high-density adapter cables. For simultaneous timing and state analysis for all signals, additional connectors must be used.

Note: * - Active Low

Mictor 38		Logic Analyzer		Microprocessor	
Conn.	Pin#	Pod #	Bit#	Pin#	Signal name
J1	38	1	0	A9	A31(LSB)
	36		1	A11	A30
	34		2	A12	A29
	32		3	A10	A28
	30		4	A13	A27
	28		5	C10	A26
	26		6	D10	A25
	24		7	C11	A24
	22		8	B11	A23
	20		9	B10	A22
	18		10	B12	A21
	16		11	C12	A20
	14		12	D11	A19
	12		13	D9	A18
	10		14	B13	A17
	8		15	C13	A16
	6		OR	L1	STS#
<hr/>					
J1	37	2	0	D12	A15
	35		1	A14	A14
	33		2	B14	A13
	31		3	C14	A12
	29		4	A15	A11
	27		5	B15	A10
	25		6	C15	A9
	23		7	D15	A8
	21		8	A16	A7
	19		9	B16	A6
	17		10	A17	A5
	15		11	B17	A4
	13		12	C16	A3
	11		13	A18	A2
	9		14	B18	A1
	7		15	B19	A0(MSB)
5	CLK	W3	CLKOUT*		

Mictor 38		Logic Analyzer		Microprocessor	
Conn.	Pin#	Pod #	Bit#	Pin#	Signal name
J2	38	3	0	T7	D31(LSB)
	36		1	U6	D30
	34		2	W5	D29
	32		3	V6	D28
	30		4	V12	D27
	28		5	U7	D26
	26		6	T8	D25
	24		7	V7	D24
	22		8	U12	D23
	20		9	T9	D22
	18		10	U8	D21
	16		11	V8	D20
	14		12	U9	D19
	12		13	V9	D18
	10		14	T12	D17
8	15	U10	D16		
6	CLK	C9	TS1Z1		
<hr/>					
J2	37	4	0	T10	D15
	35		1	V10	D14
	33		2	V13	D13
	31		3	T13	D12
	29		4	U11	D11
	27		5	V11	D10
	25		6	T11	D9
	23		7	U13	D8
	21		8	W6	D7
	19		9	W7	D6
	17		10	W9	D5
	15		11	W13	D4
	13		12	W10	D3
	11		13	W11	D2
	9		14	W12	D1
7	15	W14	DO (MSB)		
5	CLK	B9	TS1Z0		
<hr/>					
J3	38	5	0	A5	WE3*/BS_B3*/PCWE*
	36		1	B6	WE2*/BS_B2*/PCOE*
	34		2	A6	WE1*/BS_B1*/IOWR*
	32		3	C7	WE0*/BS_B0*/IORD*
	30		4	B8	BS_A3*
	28		5	A7	BS_A2*
	26		6	C8	BS_A1*
	24		7	D8	BS_A0*
	22		8	C4	CS7*/L_CE2_B*
	20		9	D5	CS6*/L_CE1_B*
	18		10	B4	CS5*
	16		11	A4	CS4*
	14		12	E4	CS3*
	12		13	D4	CS2*
	10		14	A2	CS1*
8	15	C3	CS0*		
6	CLK	D1	TEA*		

Mictor 38		Logic Analyzer		Microprocessor	
Conn.	Pin#	Pod #	Bit#	Pin#	Signal name
J3	37	6	0	F3	TS*
	35		1	B2	RD/WR*
	33		2	F1	BURST*
	31		3	D2	BDIP/GPLB5*
	29		4	E3	B1*
	27		5	G4	BR*
	25		6	E1	BB*
	23		7	E2	BG*
	21		8	H1	IP_B7/PTR/AT3
	19		9	K3	IP_B6/DSDI/AT0
	17		10	J4	IP_B5/LWP1/VF1
	15		11	G2	IP_B4/LWP0/VF0
	13		12	G1	IP_B3/LWP2/VF2
	11		13	J2	IP_B2/IOIS16_B*/AT2
	9		14	J3	VFLS1/IP_B1/IWP1
7	15	H2	VFLS0/IP_B0/IWP0		
5	CLK	C2	TA*		
<hr/>					
J4	38	7	0	T3	IP_A7
	36		1	T6	IP_A6
	34		2	U5	IP_A5
	32		3	U4	IP_A4
	30		4	W2	IP_A3
	28		5	U3	IP_A2/IOIS16_A*
	26		6	T4	IP_A1
	24		7	T5	IP_A0
	22		8	K1	KR*/IRQ4*/SPKROUT
	20		9	G3	FRZ/IRQ6*
	18		10	V4	DP3/IRQ6*
	16		11	W4	DP2/IRQ5*
	14		12	V5	DP1/IRQ4*
	12		13	V3	DP0/IRQ3*
	10		14	F2	CR*/IRQ3*
8	15	H3	RSV*/IRQ2*		
6	CLK	K2	ALEA		
<hr/>					
J4	37	8	0	B3	CE1_A*
	35		1	B1	UPWAITB*/GPLB4*
	33		2	C1	UPWAITA*/GPLA4*
	31		3	R3	WAIT_A*
	29		4	R4	WAIT_B*
	27		5	P2	SRESET*
	25		6	N4	HRESET*
	23		7	P3	RSTCONF*
	21		8	R2	PORESET*
	19		9	M4	OP3/MODCK2/DSD0
	17		10	L1	OP2/MODCK1/STS*
	15		11	L2	OP1
	13		12	L4	OP0
	11		13	N3	TEXP
	9		14	J1	ALEB/DSCK/AT1
7	15				
5	CLK	N2	EXTCLK		

Mictor 38		Logic Analyzer		Microprocessor	
Conn.	Pin#	Pod #	Bit#	Pin#	Signal name
J5	38	9	0	C18	PA15/RXD1
	36		1	D17	PA14/TXD1
	34		2	E17	PA13/RXD2
	32		3	F17	PA12/TXD2
	30		4	G16	PA11/L1TXDB
	28		5	J17	PA10/L1RXDB
	26		6	K18	PA9/L1TXDA
	24		7	L17	PA8/L1RXDA
	22		8	M19	PA7/CLK1/TIN1/L1RCLKA/BRGOUT1
	20		9	M17	PA6/CLK2/TOUT1*/BRGCLK1
	18		10	N18	PA5/CLK3/TIN2/L1TCLKA/BRGOUT2
	16		11	P19	PA4/CLK4/TOUT2*
	14		12	P17	PA3/CLK5/TIN3/BRGOUT3
	12		13	R18	PA2/CLK6/TOUT3*/L1RCLKB/BRGCLK2
	10		14	T19	PA1CLK7/TIN4/BRGOUT4
	8		15	U19	PA0/CLK8/TOUT4*/L1TCLKB
	6		CLK	A3	CE2_A*
<hr/>					
J5	37	10	0	D16	PC15/DREQ1*/RTS1/L1ST1
	35		1	D18	PC14/DREQ2*/RTS2*/L1ST2
	33		2	E18	PC13/L1RQB/ L1ST3
	31		3	F18	PC12/L1RQA/ L1ST4
	29		4	J19	PC11/CTS1*
	27		5	K19	PC10/CD1*/TGATE1*
	25		6	L18	PC9/CTS2*
	23		7	M18	PC8/CD2*/TGATE2*
	21		8	M16	PC7/L1TSYNCB/SDACK2*/CTS3*
	19		9	R19	PC6/L1RSYNCB/CD3*
	17		10	T18	PC5/L1TSYNCA/SDACK1*/CTS4*
	15		11	T17	PC4/L1RSYNCA/CD4*
	13		12	C6	OE*/GPLA1*/GPLB1*
	11		13	B5	GPLA2*/GPLB2*/CS2*
	9		14	C5	GPLA3*/GPLB3*/CS3*
	7		15	D3	GPLA5*
	5		CLK	D7	GPLA0*/GPLB0*
<hr/>					
J6	38	11	0	C17	PB31/SPISEL*/RRJECT1*
	36		1	C19	PB30/SPICLK
	34		2	E16	PB29/SPIMOSI
	32		3	D19	PB28/SPIMISO/BRGOUT4
	30		4	E19	PB27/I2CSDA/BRGOUT1
	28		5	F19	PB26/I2CSCL/BRGOUT2
	26		6	J16	PB25/SMTXD1
	24		7	J18	PB24/SMRXD1
	22		8	K17	PB23/SMSYN1*/SDACK1*
	20		9	L19	PB22/SMSYN2*/SDACK2*
	18		10	K16	PB21/SMTXD2/L1CLKOB
	16		11	L16	PB20/SMRXD2/L1CLKOA
	14		12	N19	PB19/RTS1*/L1ST1
	12		13	N17	PB18/RTS2*/L1ST2
	10		14	P18	PB17/L1RQB/L1ST3
	8		15	N16	PB16/L1RQA/L1ST4
	6		CLK	W15	IRQ7*

Mictor 38		Logic Analyzer		Microprocessor	
Conn.	Pin#	Pod #	Bit#	Pin#	Signal name
J6	37	12	0	R17	PB15/BRGOUT3
	35		1	U18	PB14/RSTR1*
	33		2	U17	PD15/LD8/L1TSYNCA
	31		3	V19	PD14/LD7/L1RSYNCA
	29		4	V18	PD13/LD6/L1TSYNCB
	27		5	R16	PD12/LD5/L1RSYNCB
	25		6	T16	PD11/LD4/RXD3
	23		7	W18	PD10/LD3/TXD3
	21		8	V17	PD9/LD2/RXD4
	19		9	W17	PD8/LD1/TXD4
	17		10	T15	PD7/LD0/RTS3*
	15		11	V16	PD6/LCD_AC/LOE/RTS4*
	13		12	U15	PD5/FRAME_VSYNC/RRJECT2*
	11		13	U16	PD4/LOAD_HSYNC/RRJECT3*
	9		14	W16	PD3/SHIFT_CLK/RRJECT4*
	7		15	V14	IRQ0*
	5		CLK	U14	IRQ1*

System Configuration and Ordering Information

Agilent makes it easier and more economical to order your emulation or analysis solution by providing solution product numbers. The table below shows the system components you

need to order and what is included in each one. The solution product numbers do not include logic analysis. The Agilent 16700A Series logic analysis systems need to be ordered separately.

If you want to configure or upgrade your system with individual products, see page 21 for individual product number information.

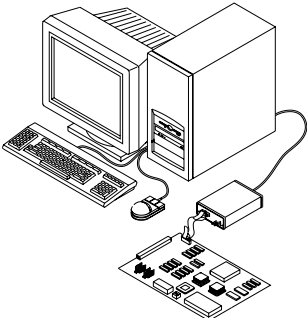
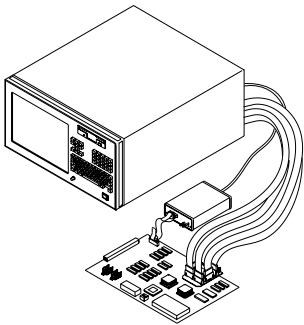
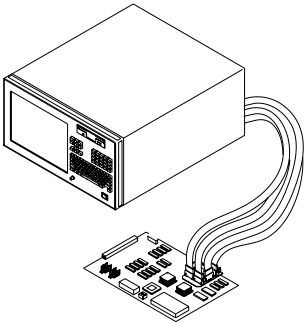
	Solution	Products to Order	Included Components
	JTAG Emulation <ul style="list-style-type: none"> MPC 8XX Emulation Probe Debugger Connection 	<ul style="list-style-type: none"> E5900B #300 Order directly from GreenHills, Microtex., Diab SDS, or Wind River Systems, Inc. 	
	<hr/> Emulation Solution with Real-Time Trace		
	<ul style="list-style-type: none"> Agilent 16700A Series Logic Analysis System 	<ul style="list-style-type: none"> Refer to Agilent publication 5966-3148E for logic analyzer configuration Contact your Agilent field engineer for latest logic analyzer information 	
	<ul style="list-style-type: none"> MPC 860/821 Emulation Using Analysis Probe* 	<ul style="list-style-type: none"> E9484B #002 	<ul style="list-style-type: none"> SA nalysis Probe Source Correlation Tool Set Emulation Module
	<ul style="list-style-type: none"> MPC 860/821 Emulation Using Mictor Probing 	<ul style="list-style-type: none"> E9484B #001 	<ul style="list-style-type: none"> Source Correlation Tool Set Emulation Module Inverse Assembler
	<ul style="list-style-type: none"> Debugger Connection Debugger Connection Optional System Performance Analyzer Tool Set 	<ul style="list-style-type: none"> Three E5346B High-Density Termination Adapters E5446-68701 Mictor Connector Kit Order directly from GreenHills, Microtec, Diab SDS, or Wind River Order directly from ARM, Inc., GreenHills Software, Inc., or Wind River Systems Inc. B4600B 	
	<hr/> Logic Analysis Solution		
	<ul style="list-style-type: none"> Agilent 16700A Series Logic Analysis System 	<ul style="list-style-type: none"> Refer to Agilent publication 5966-3148E for logic analyzer configuration Contact your Agilent field engineer for latest logic analyzer information 	
	<ul style="list-style-type: none"> MPC 860/821 Logic Analysis Solution Using Analysis Probe* MPC 860/821 Logic Analysis High-Density Connectors 	<ul style="list-style-type: none"> E9584B #002 E9584B #001 High-Density Termination Adapters E5346-68701 Mictor Connector Kit 	<ul style="list-style-type: none"> Analysis Probe Inverse Assembler Inverse Assembler
<ul style="list-style-type: none"> Connection to Target with Medium-Density Connectors Optional Source Correlation Tool Set Optional System Performance Analysis Tool Set Optional Emulation Module 	<ul style="list-style-type: none"> Four to six 01650-63203 Termination Adapters B4620B B4600B E5901B #080 		

Individual Components Ordering Information

Description	Product
Emulation Probe	E5900B #080
Emulation Module	E5901B #080
Analysis Probe	E9584B #002
Inverse Assembler	E9595B #001
Emulation Module and Emulation Probe Migration	E5902B #080
Source Correlation Tool Set	B4620B
System Performance Analysis Tool Set	B4600B
High-Density Termination Adapter	E5346A
Mictor Connector Kit	E5346-68701
Extender	E2476-87602
BGA Probing Kit	E5355A

Related Agilent Literature

Agilent 16600A and 16700A Logic Analysis System Mainframes, Product Overview

Pub. Number

5966-3107E

For training offered in other geographies and languages, consult the Agilent Test and Measurement education web site: <http://www.hp.com/go/tmeducation>.

Agilent Logic Analysis Systems Upgrade, Product Overview

5966-3059E

For consulting services, contact your local Agilent Test and Measurement sales office. An Agilent Digital Systems Consultant can help you solve tough digital debug problems by showing you how to apply Agilent tools and debug best practices. Topics covered can include:

System Configuration for the Agilent 16700A Series Logic Analysis Systems, Configuration Guide

5966-3148E

- System Installation
- Complex Triggering
- Multiple Bus Analysis
- Source-Line Referencing
- System Performance Analysis
- Instrumenting Code to Solve Specific Issues
- Bus Signal Timing Analysis
- Signal Integrity Analysis
- Agilent 16700A Networking

Training and Consulting

Agilent has experienced Digital Systems Consultants who can help you maximize the utilization of your emulation and analysis system through training and consulting. Digital Systems Consultants are peaked in debugging complex digital hardware/software problems and hardware/software integration.

Agilent training may be delivered through scheduled courses, on-site classes, or one-on-one consulting. Agilent has courses for the beginner as well as advanced users migrating from the 16500 Series system. Call 1-800-593-6632 in the U.S. for information about training schedules and location or to register.

Topics related to debug of MPC 8XX microprocessor-based targets can include:

- Instruction/Data Cache Related Issues
- Checkstop Analysis
- Single and Multiple Beat Bus Cycle
- Pipelining and Bursts

Agilent Technologies' Test and Measurement Support, Services, and Assistance

Agilent Technologies aims to maximize the value you receive, while minimizing your risk and problems. We strive to ensure that you get the test and measurement capabilities you paid for and obtain the support you need. Our extensive support resources and services can help you choose the right Agilent products for your applications and apply them successfully. Every instrument and system we sell has a global warranty. Support is available for at least five years beyond the production life of the product. Two concepts underlay Agilent's overall support policy: "Our Promise" and "Your Advantage."

Our Promise

Our Promise means your Agilent test and measurement equipment will meet its advertised performance and functionality. When you are choosing new equipment, we will help you with product information, including realistic performance specifications and practical recommendations from experienced test engineers. When you use Agilent equipment, we can verify that it works properly, help with product operation, and provide basic measurement assistance for the use of specified capabilities, at no extra cost upon request. Many self-help tools are available.

Your Advantage

Your Advantage means that Agilent offers a wide range of additional expert test and measurement services, which you can purchase according to your unique technical and business needs. Solve problems efficiently and gain a competitive edge by contracting with us for calibration, extra-cost upgrades, out-of-warranty repairs, and on-site education and training, as well as design, system integration, project management, and other professional services. Experienced Agilent engineers and technicians worldwide can help you maximize your productivity, optimize the return on investment of your Agilent instruments and systems, and obtain dependable measurement accuracy for the life of those products.

By Internet, phone, or fax, get assistance with all your test and measurement needs

Online

www.agilent.com/find/assist

Phone or Fax

United States:

(tel) 1 800 452 4844

Canada:

(tel) 1 877 894 4414

(fax) (905) 206 4120

Europe:

(tel) (31 20) 547 2000

Japan:

(tel) (81) 426 56 7832

(fax) (81) 426 56 7840

Latin America:

(tel) (305) 267 4245

(fax) (305) 267 4286

Australia:

(tel) 1-800 629 485

(fax) (61 3) 9272 0749

New Zealand:

(tel) 0 800 738 378

(fax) (64 4) 495 8950

Asia Pacific:

(tel) (852) 3197 7777

(fax) (852) 2506 9284

Product specifications and descriptions in this document subject to change without notice.

Copyright © 2000 Agilent Technologies

Printed in U.S.A. 05-00

5966-2866E

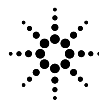

Agilent Technologies
Innovating the HP Way