

# Agilent E6501A, E6502A, E6503A VXI Receivers

## Data Sheet

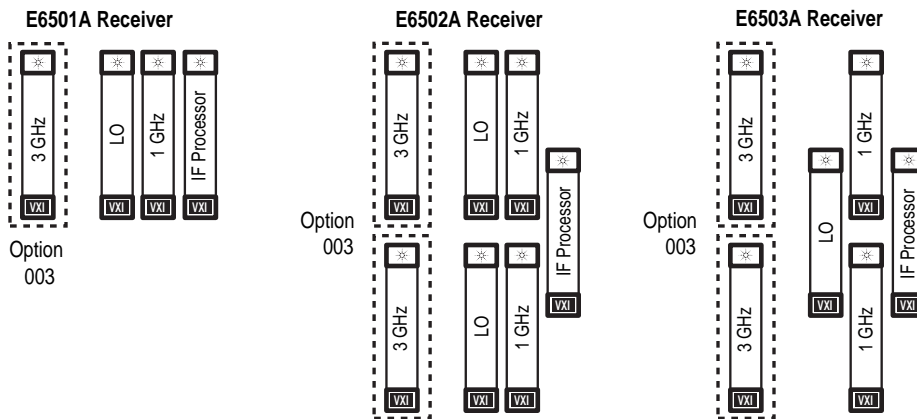

Agilent E6501A, E6502A, and E6503A VXI receivers each cover the 2 MHz to 1000 MHz frequency range. Option 003 extends the frequency range to 3000 MHz.

This document summarizes the performance of the Agilent Technologies E6501A, E6502A, and E6503A VXI receiver configurations. The E65XX modular family of DSP-based VXI receivers offers systems integrators high-performance receiver hardware and VXI plug-and-play software drivers for developing their own systems for frequency monitoring and surveillance applications. Each receiver configuration provides frequency coverage from 2 MHz to 1000 MHz (or to 3000 MHz with Option 003). *Performance is not specified below 20 MHz.* For more information on the E65XX receivers, refer to the last page for a list of related documents.

Receiver performance categories include the following: **specifications, typicals, or characteristics.** **Specifications** describe warranted performance over the temperature range of 0 °C to 55 °C and include a 30-minute warmup from ambient conditions. **Typical** or **characteristic** information provides useful information by giving non-warranted performance parameters. **Typical** refers to test data at the fiftieth percentile, averaged over the frequency range, for 25 °C (room temperature). **Characteristic** information describes product performance for parameters that are either not subject to variation, non-measurable,

verifiable through functional pass-fail tests, or as a matter of routine not measured.

**Specifications, typicals, and characteristics** apply to the 20 MHz to 1000 MHz frequency range (and to 3000 MHz with Option 003) for each of the receiver configurations (E6501A, E6502A, and E6503A), unless otherwise noted. **Specifications, typicals, and characteristics** apply only at the E6501A, E6502A, and E6503A receiver system-level configuration (not at the module level). The minimum receiver system consists of the three module set: the E6401A downconverter, the E6402A LO, and E6404A IF processor. Option 003 adds one or two E6403A 3 GHz block downconverter modules, depending on the receiver model. **Specifications, typicals, and characteristics** are not available at the individual E640X series VXI module level (i.e., E6401A, E6402A, E6403A, and E6404A). **Specifications, typicals, and characteristics** assume that the receivers are used in Agilent Technologies VXI mainframes (E1421B and E1401B recommended) and that the Agilent VXI modules are connected to a common 10 MHz reference. The E6402A LO module provides a 10 MHz output and 10 MHz TTL output for connection to the E6404A IF processor and MXI modules, respectively.

## Frequency

### Frequency range

20 MHz<sup>1</sup> to 1000 MHz

20 MHz<sup>1</sup> to 3000 MHz (Option 003)

### Tuning resolution

1 Hz

### Synthesizer tuning speed

1 ms (10 kHz setting), characteristic

2 ms (1 kHz setting), characteristic

4 ms (100 Hz setting), characteristic

(Data derived from register-based programming)

### Overall receiver sweep speed

2.8 GHz/s in 10.4 kHz resolution bandwidth (maximum speed using 4k FFTs of successive 8 MHz spans over the 20 MHz to 1000 MHz frequency range; does not account for computer overhead time), characteristic

### Tuning accuracy

(center frequency x reference accuracy)

Internal OCXO reference accuracy:<sup>2</sup>  $1 \times 10^{-6}$  /yr

External reference input: requires 10 MHz reference signal with level 0 dBm  $\pm$  3 dB

## Amplitude

### Input parameters

#### RF input impedance

50 ohms, characteristic

#### RF input connector

SMA

#### Input VSWR

2:1, characteristic

#### Maximum input without damage

Average continuous RF power: +20 dBm, characteristic

DC voltage: 20 volts, characteristic

#### Maximum recommended operating level at RF input

-20 dBm with 0 dB RF attenuation

(+10 dBm with 30 dB attenuation), characteristic

#### RF input attenuation

0 to 30 dB in 10 dB steps, characteristic

#### RF preselection

Preselector band	Filter frequency range (characteristic)
1	(40 MHz LPF)
2	40 to 60 MHz
3	60 to 84 MHz
4	84 to 118 MHz
5	118 to 170 MHz
6	170 to 230 MHz
7	230 to 350 MHz
8	350 to 450 MHz
9	450 to 750 MHz
10	750 to 1000 MHz
11	1000 to 1250 MHz
12	1250 to 1800 MHz
13	1800 to 2400 MHz
14	2400 to 3000 MHz

## Detection modes

### DSP-based demodulation

AM, LSB, USB, ISB, FM, CW, PM

### Simultaneous demods

up to 10 (optional configuration; see page 4 for bandwidth requirements)

## Dynamic range parameters

### Noise figure

10 dB, typical (20 MHz to 1 GHz)<sup>3</sup>

14 dB, typical (1 GHz to 3 GHz)

### Sensitivity

(12 dB SINAD; 1 V<sub>rms</sub> audio output; modulation = 1 kHz;

analog filter = 30 kHz BW; FM de-emphasis ON), typical values:

Frequency (DDC BW = 5 kHz; 50% AM)	AM sensitivity	FM sensitivity (DDC BW = 25 kHz; FM dev = 5 kHz)
500 MHz	-107 dBm	-112 dBm
1125 MHz	-105 dBm	-110 dBm
1500 MHz	-105 dBm	-110 dBm
2000 MHz	-105 dBm	-110 dBm
2700 MHz	-103 dBm	-108 dBm

### Intermodulation – second order

SOI: +67 dBm, typical (referenced to the RF input; 0 dB RF attenuation)

### Intermodulation – third order

TOI: +15 dBm (20 MHz spacing), typical (referenced to the RF input; 0 dB RF attenuation) Narrowband intermodulation distortion for 2 signals at -20 dBm and 125 kHz spacing using the 8 MHz analog filter: -63 dBc, typical (referenced to the RF input; 0 dB RF attenuation)

### Image rejection

95 dB

### IF rejection

90 dB

### Phase noise @ 20 kHz offset

-100 dBc/Hz, characteristic

### Internally-generated spurious

-100 dBm, equivalent input

### LO emissions

-110 dBm (in 20 to 1000 MHz RF band)

-100 dBm (in 1000 to 3000 MHz RF band)

### Blocking

<2 dB,<sup>4</sup> characteristic

### Reciprocal mixing

<3 dB,<sup>5</sup> characteristic

1 The software driver supports tuning the receiver down to 2 MHz. However, specifications, typicals, and characteristics do not apply below 20 MHz.

2 Adjustment procedure is provided in the user manual.

3 Add 1 dB when using the E6403A 20 to 3000 MHz input.

4 Attenuation of -100 dBm desired signal by unwanted -5 dBm signal at 250 kHz offset in 25 kHz DDC BW and 30 kHz analog BW.

5 S+N/N degradation of desired signal by unwanted signal 350 kHz offset and 70 dB higher in 20 kHz DDC BW and 30 kHz analog BW at RF-tuned frequency of 85 MHz.

## IF (intermediate frequency) processing

### IF section: analog signal conditioning and ADC

#### Analog IF input filter bandwidths (minimum)

8 MHz, 700 kHz, and 30 kHz, characteristic (Filters centered at 21.4 MHz. The 8 MHz filter is an anti-alias filter. The 700 kHz and 30 kHz filters are adjacent channel rejection filters.)

#### Analog gain control

manual and autoranging

#### Input range settings

-48 dBm to 0 dBm in 2 dB steps (overrange from +2 dBm to +12 dBm also available)

#### Autoranging gain response time

<1  $\mu$ s, characteristic

Attack: <1  $\mu$ s, characteristic

Decay: <2.9 ms, characteristic

#### Overall gain control range

150 dB, characteristic (includes RF attenuation, ADC dynamic range, and autoranging)<sup>6</sup>

#### Dual input IF channel isolation

$\leq -120$  dBm, characteristic. (For a signal at full scale at the ADC on channel 1, channel 2 at maximum gain will have an equivalent input signal level  $\leq -120$  dBm, and vice versa. Applies to E6502A and E6503A dual channel receivers only.)

#### ADC sampling rate

28.5333 MSa/s,<sup>7</sup> characteristic

#### ADC output data rates

full rate ADC at 28.5333 MSa/s using 2 link ports (16 bits wide; 57.0666 MBytes/sec data rate. See IF section for link port information. Spectral information is inverted for bands 11 and 12 for full rate ADC output.)

### IF section – IF processor dynamic range parameters

#### Harmonic distortion<sup>8,9,10</sup>

-75 dBc or  $< -140$  dBm,<sup>11</sup> characteristic

#### Spurious responses<sup>8,9,12</sup>

-110 dBc or  $< -140$  dBm,<sup>11</sup> characteristic

#### Signal-to-noise ratio<sup>13,14</sup>

62 dB, characteristic

#### Internally generated spurious responses<sup>8,15,16</sup>

$< -140$  dBm<sup>11</sup>, characteristic

### IF section – digital (general)

#### Number of digital downconverters (DDC)

Standard Agilent E6501A receiver: 1

Standard Agilent E6502A receiver: 2 (1 per mezzanine)

Standard Agilent E6503A receiver: 2 (on mezzanine #1)

Optionally: 5 per mezzanine

(10 total per IF processor module with two mezzanines; when DSP on mezzanine #1 used for search, only the DDCs on mezzanine #2 are usable for digital I/Q output or demodulation)

#### DDC tuning range

8 MHz, maximum (limited to analog IF input filter; centered at 21.4 MHz), characteristic

#### DDC resolution

16 bits

DDC full scale automatically adjusted over 54 dB range using dynamic range optimization, characteristic

#### Dynamic range optimization response time

Variable, adjustable in 500  $\mu$ s steps

Attack: 500  $\mu$ s to 1 s, characteristic

Decay: 500  $\mu$ s to 1 s, characteristic

#### Digital IF bandwidths

36 different filters with the following 3 dB BWs: 247 Hz, 493 Hz, 740 Hz, 1 kHz, 2.4 kHz, 3.3 kHz, 5 kHz, 6.3 kHz, 10 kHz, 12 kHz, 15 kHz, 20 kHz, 25 kHz, 30 kHz, 34 kHz, 44 kHz, 54 kHz, 62 kHz, 74 kHz, 83 kHz, 93 kHz, 109 kHz, 119 kHz, 138 kHz, 154 kHz, 167 kHz, 187 kHz, 201 kHz, 218 kHz, 238 kHz, 262 kHz, 291 kHz, 327 kHz, 374 kHz, 436 kHz, 462 kHz (characteristics) (all 5 DDCs per mezzanine are set to the same BW)

#### Digital bandwidth shape factor

<1.5:1 (102 dB to 3 dB BW ratio), characteristic

#### Digital output interface

analog devices 2106X DSP (Sharc) link ports (2 link ports per mezzanine)

#### Link port connector type

AMP 1-104074-0 connector on E6404A front panel (mating connector: AMP 487550-5 housing and contacts)

#### Number of digital I/Q outputs

1 per DDC (up to 10 DDCs available optionally).

(The number of DDCs depends on model and option configuration. Refer to Agilent E65XX configuration guide.)

#### Bandwidth of digital I/Q outputs

from 247 Hz to 462 kHz (The BW depends on the number of DDCs simultaneously accessed. Refer to the table in section A.)

#### DDC decimated sample rate (samples/sec)

1.8181 x DDC BW, characteristic

#### 4 MByte data RAM

optional (4 MBytes per mezzanine; 2 mezzanines total);

used for data buffering or delay memory applications

(not available for programming)

6 Actual adjustable range using the software driver is 90 dB (30 dB RF attenuation and 60 dB analog IF gain). Remaining 60 dB range is accomplished with the ADC dynamic range (S/N of > 60 dB at Nyquist sampling rate of 28.533 MSa/s).

7 Sample rate is calculated by multiplying 21.4 MHz by 4/3.

8 8 MHz bandwidth (undecimated ADC data).

9 Input signal equal to input range setting (see "input range settings" listed previously).

10 Includes aliased distortion components.

11 Referred to E6404A input.

12 Includes non-harmonically-related spurious, clock spurious, sidebands, etc.

13 14.266 MHz Nyquist bandwidth.

14 For input range setting of -10 dBm and signal at ADC clipping level.

15 E6404A input terminated in 50  $\Omega$ .

16 With input range setting of -48 dBm.

## IF section – digital I/Q outputs

### Number of simultaneous digital I/Q outputs per mezzanines

up to 5 (see table), characteristic (up to 10 using optional second mezzanine)<sup>17</sup>

DDC bandwidth (kHz)	0.247 to 34	44 to 54	62 to 83	93 to 187	201 to 462
Number of simultaneous I/Q outputs	5	4	3	2	1

### Output bandwidth

set by DDC

### Output interface

Sharc link ports

### Link port output data rate (bytes/second)

1.8181 x 4 x DDC BW, characteristic. I/Q complex data is 16 bits wide (16 bits for I and 16 bits for Q; 4 bytes per sample).

See “Digital IF bandwidths” on page 3 for DDC BW range.

## IF section – demodulated analog audio outputs

### DSP-based detection modes (demodulation)

AM, LSB, USB, ISB,<sup>18</sup> FM, CW, PM

### Number of simultaneous demodulated signals per mezzanine

up to 5 signals (10 using optional second mezzanine),<sup>17</sup> characteristic

<b>AM</b>	5	4	3	2	1
DDC bandwidth (kHz)	0.247 to 30	34 to 54	62 to 83	93 to 167	187 to 374
<b>FM</b>	5	4	3	2	1
DDC bandwidth (kHz)	0.247 to 30	34 to 54	62 to 83	93 to 187	201 to 462
<b>USB/LSB<sup>18</sup></b>	5	4	3	2	1
DDC bandwidth (kHz)	0.247 to 25	30 to 34	44	54 to 74	83 to 167
<b>CW</b>	5	4	3	2	1
DDC bandwidth (kHz)	0.247 to 30	34 to 54	62 to 83	93 to 187	201 to 462
<b>PM</b>	5	4	3	2	1
DDC bandwidth (kHz)	0.247 to 25	30	34	44 to 62	74 to 138

### Maximum realtime demodulated bandwidth<sup>19</sup> (single channel per mezzanine):

AM: 374 kHz

FM: 462 kHz

LSB/USB: 167 kHz

ISB: 138 kHz

CW: 462 kHz

PM: 138 kHz

### Analog audio output bandwidth

15 kHz, maximum, characteristic

### Maximum audio output

1 volt RMS into 600 ohms, characteristic

### Audio output connector type

AMP 750823-1 on front panel of Agilent E6404A IF processor module for connection to separately ordered cable and audio breakout box (or order AMP 750833-1 cable connector and 750850-3 backshell kit to configure your own cable)

### External cable and audio breakout box

ordered separately as Agilent E3245A (uses 10 mini-phone jacks for connection to headphones or amplified speakers)

### Trigger input

TTL level (uses 2 pins on AMP 750823-1 audio connector); used to synchronize data

### Trigger output

TTL level (uses 2 pins); controllable from software driver

### COR (carrier operated relay)

use TTL trigger output signal (no traditional COR dry contacts)

### Squelch range

–125 dBm to –20 dBm, characteristic

### ALC (automatic level control) range

adjustable; >100 dB, characteristic (volume control; maintains audio level to within 25% full scale; used for USB, LSB, and ISB)

### ALC response time

adjustable in 1  $\mu$ s steps;

range: 1  $\mu$ s to 10 s, characteristic

### AFC (automatic frequency control) tracking range

$\pm 1/2$  DDC BW, characteristic

### FM de-emphasis

75  $\mu$ s, characteristic

<sup>17</sup> The standard receiver includes one or two DDCs, depending on the specific model number. Refer to “IF section – digital (general)” on page 3. Options are required for two or five DDCs per mezzanine. The E6501A and E6503A require an option for a second mezzanine. Refer to the Agilent E65XX configuration guide for more information.

<sup>18</sup> Independent sideband (ISB) is supported. However, each signal channel requires two DDC channels.

<sup>19</sup> Maximum modulation frequency is dependent on modulation format. For example, the maximum modulation frequency for AM is half the bandwidth, so the maximum modulation frequency is 187 kHz.

## Front-panel connectors

### Agilent E6401A VXI module

#### (20 to 1000 MHz downconverter)

20 to 1000 MHz input, SMA  
Block downconverter input, SMA  
1st LO input, SMC  
2nd LO input, SMC  
21.4 MHz IF output, SMB

### Agilent E6402A VXI module (local oscillator)

1st LO output, SMC  
2nd LO output, SMC  
Block downconverter LO output, SMC  
3rd LO output, SMB  
Reference output, SMB  
External reference input, SMB  
Reference TTL output, SMB  
(The E6503A dual channel receiver includes the E6402A Option 002 LO module which adds a second set of the following outputs: 1st LO output, 2nd LO output, and block downconverter LO output.)

### Agilent E6403A VXI module

#### (1000 to 3000 MHz block downconverter)

20 to 3000 MHz input, SMA  
20 to 1000 MHz output, SMA  
Block downconverter output, SMA  
Block downconverter LO input, SMC

### Agilent E6404A VXI module (IF processor)

Ch 1 IF input, SMB  
Ch 2 IF input, SMB (option required)  
Reference input, SMB  
Reference output, SMB  
Audio output/trigger input (on mezzanine 1)  
Audio output/trigger input (on optional mezzanine 2)  
Link port 1 and 2 outputs (on mezzanine 1)  
Link port 1 and 2 outputs (on optional mezzanine 2)

## VXI information

### VXI control

VXI plug-and-play driver for Windows® NT O/S;  
National Instruments MXI-2 interface required for NT O/S

### Module sizes

VXI C-size modules

### Slots used

3 slots (E6501A 1 GHz Rx)  
4 slots (E6501A Option 003 3 GHz Rx)  
5 slots (E6502A 1 GHz Rx)  
7 slots (E6502A Option 003 3 GHz Rx)  
4 slots (E6503A 1 GHz Rx)  
6 slots (E6503A Option 003 3 GHz Rx)

### VXI interface

Requires MXI interface (not included; refer to Agilent E65XX configuration guide)

## Power requirements<sup>20</sup>

### E6501A (20 to 1000 MHz)

90 watts, characteristic

### E6501A Option 003 (20 to 3000 MHz)

104 watts, characteristic

### E6502A (20 to 1000 MHz)

126 watts, characteristic

### E6502A Option 003 (20 to 3000 MHz)

154 watts, characteristic

### E6503A (20 to 1000 MHz)

104 watts, characteristic

### E6503A Option 003 (20 to 3000 MHz)

132 watts, characteristic

## Physical parameters

### Weight (characteristics)<sup>21</sup>

#### E6501A (20 to 1000 MHz) receiver

8.6 kg (18 lbs, 11 oz)

#### E6501A Option 003 (20 to 3000 MHz) receiver

11.3 kg (24 lbs, 9 oz)

#### E6502A (20 to 1000 MHz) receiver

14.4 kg (31 lbs, 5 oz)

#### E6502A Option 003 (20 to 3000 MHz) receiver

19.8 kg (43 lbs, 1 oz)

#### E6503A (20 to 1000 MHz) receiver

11.3 kg (24 lbs, 9 oz)

#### E6503A Option 003 (20 to 3000 MHz) receiver

16.7 kg (36 lbs, 5 oz)

#### E6401A module (20 to 1000 MHz downconverter)

2.7 kg (5 lbs, 14 oz)

#### E6402A module (local oscillator)

3.1 kg (6 lbs, 12 oz)

#### E6403A module (1000 to 3000 MHz block downconverter)

2.7 kg (5 lbs, 14 oz)

#### E6404A module (IF processor)

2.8 kg (6 lbs, 1 oz)

<sup>20</sup> Power requirements based on the E6404A IF processor with two IF channels, two mezzanines, ten DDCs, two DSPs, and two 4 Mbyte RAMs.

<sup>21</sup> E6404A IF processor weight includes complete set of options (see previous footnote).

## Dimensions

Refer to the diagram shown here.

All dimensions are considered characteristics.

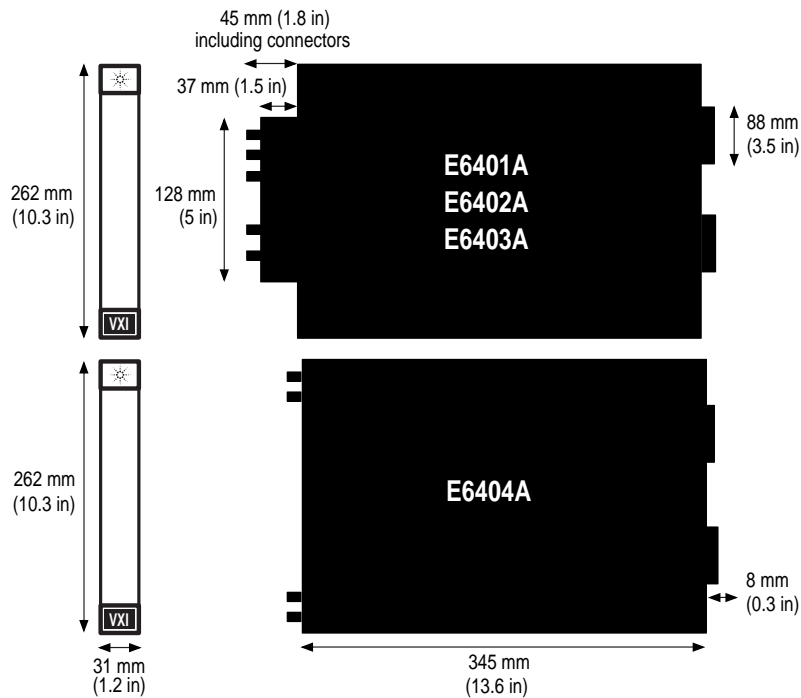

Dimensions of VXI modules included in the Agilent E65XXA receivers.

Each module occupies a single C-size slot. (Front-panel connectors vary with model and option.)

## Environmental

### Operating temperature

0 °C to 55 °C

### Storage temperature

-20 °C to +70 °C

## EMC

CISPR 11 Class A; MIL-STD-461C RE02 Parts 5 and 7; IEC 801-3;  
ETM 765 RS2; IEC 1000-4-6; VXI-EDG B.8.6.3 and B.8.6.4;  
IEC 801-2 and ETM 765

## Humidity

ETM 758 Class A2, B1, B2 (40 °C, 95% R.H.)

## Shock

MIL-T-28800E; ETM 760

## Vibration

MIL-T-28800E Class 3; ETM 759  
Class B2; ETM 762

## Calibration and adjustment

### Calibration interval

2 years

### Internal timebase adjustment interval

1 year

(Timebase adjustment may be performed by customer if appropriate test equipment is available. Software to control the E65XX timebase setting is provided with the system.)

## Warranty

1 year

## Related literature

*Agilent E6501A, E6502A, E6503A VXI Receivers,*  
Product Overview (5966-0165E)

*Agilent E6501A, E6502A, E6503A VXI Receivers,*  
Configuration Guide (5966-2974E)

*Agilent E6500A VXI Tuner,*  
Product Overview (5965-5769E)

Windows is a U.S. registered trademark of Microsoft Corporation.

**Agilent Technologies' Test and Measurement Support, Services, and Assistance**

Agilent Technologies aims to maximize the value you receive, while minimizing your risk and problems. We strive to ensure that you get the test and measurement capabilities you paid for and obtain the support you need. Our extensive support resources and services can help you choose the right Agilent products for your applications and apply them successfully. Every instrument and system we sell has a global warranty. Support is available for at least five years beyond the production life of the product. Two concepts underlie Agilent's overall support policy: "Our Promise" and "Your Advantage."

**Our Promise**

"Our Promise" means your Agilent test and measurement equipment will meet its advertised performance and functionality. When you are choosing new equipment, we will help you with product information, including realistic performance specifications and practical recommendations from experienced test engineers. When you use Agilent equipment, we can verify that it works properly, help with product operation, and provide basic measurement assistance for the use of specified capabilities, at no extra cost upon request. Many self-help tools are available.

**Your Advantage**

"Your Advantage" means that Agilent offers a wide range of additional expert test and measurement services, which you can purchase according to your unique technical and business needs. Solve problems efficiently and gain a competitive edge by contracting with us for calibration, extra-cost upgrades, out-of-warranty repairs, and on-site education and training, as well as design, system integration, project management, and other professional services. Experienced Agilent engineers and technicians worldwide can help you maximize your productivity, optimize the return on investment of your Agilent instruments and systems, and obtain dependable measurement accuracy for the life of those products.

By internet, phone, or fax, get assistance with all your test and measurement needs.

**Online Assistance**

[www.agilent.com/find/assist](http://www.agilent.com/find/assist)

**Phone or Fax**

**United States:**

(tel) 1 800 829 4444

**Canada:**

(tel) 1 877 894 4414

(fax) (905) 282 6495

**China:**

(tel) 800 810 0189

(fax) 800 820 2816

**Europe:**

(tel) (31 20) 547 2323

(fax) (31 20) 547 2390

**Japan:**

(tel) (81) 426 56 7832

(fax) (81) 426 56 7840

**Korea:**

(tel) (82 2) 2004 5004

(fax) (82 2) 2004 5115

**Latin America:**

(tel) (305) 269 7500

(fax) (305) 269 7599

**Taiwan:**

(tel) 0800 047 866

(fax) 0800 286 331

**Other Asia Pacific Countries:**

(tel) (65) 6375 8100

(fax) (65) 6836 0252

(e-mail) [tm\\_asia@agilent.com](mailto:tm_asia@agilent.com)

Data Subject to Change

© Agilent Technologies, Inc. 1998, 2000

Printed in the U.S.A. May 1, 2004

5966-3344E



**Agilent Technologies**