

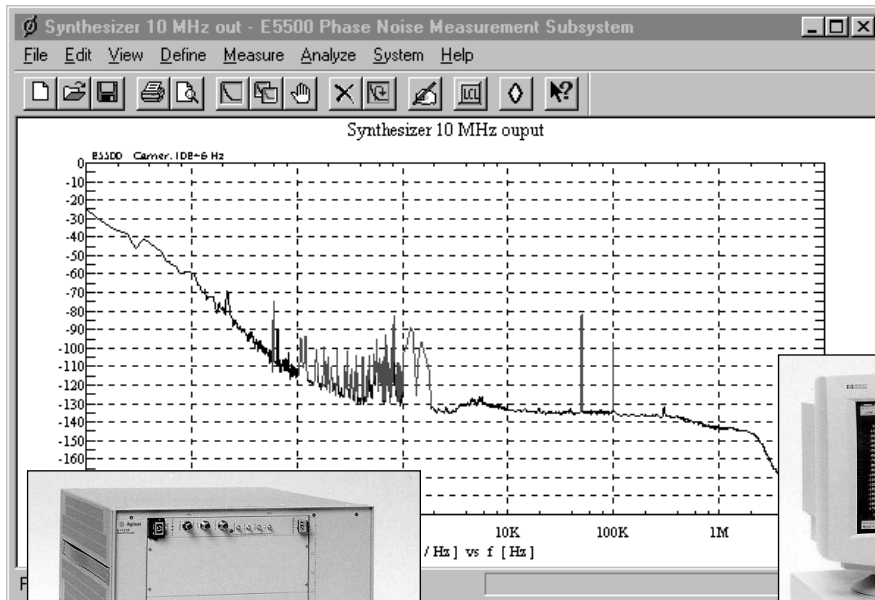

Agilent E5500 Series

Phase Noise Measurement Solutions

Product Overview



E5501A/B	50 kHz to 1.6 GHz
E5502A/B	50 kHz to 6 GHz
E5503A/B	50 kHz to 18 GHz
E5504A/B	50 kHz to 26.5 GHz

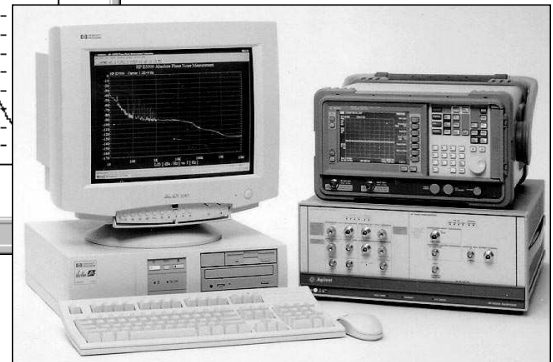
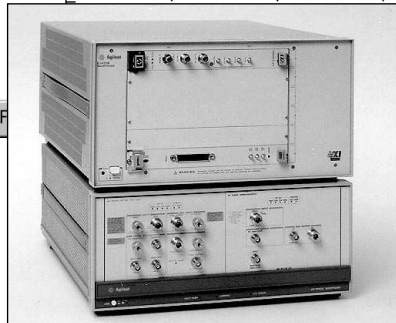

The Agilent E5500 series phase noise measurement solutions bring excellent measurement speed, offset range, and flexibility directly to the production floor or the R&D workbench.

The Agilent Technologies E5500 series of phase noise measurement solutions have been designed to minimize the production, ATE test times for one-port VCOs, DROs, crystal oscillators, and synthesizers and to maximize the capability for R&D benchtop applications.

With test times of less than 3 seconds (1 kHz to 100 kHz) and less than 30 seconds (10 Hz to 1 MHz) achievable, the E5500 A-series meets the high throughput and over-all, low cost-of-test needs for today's higher volume devices.

In addition, with a standard offset range capability from 0.01 Hz to 100 MHz, the Agilent E5500 B-series provides the capability, flexibility, and versatility to meet changing and demanding needs placed upon the R&D engineer.

By building upon 30 years of low phase noise, RF design, and measurement experience, the Agilent E5500 series solutions continue to provide excellent measurement integrity, repeatability, and accuracy.



Agilent Technologies

Innovating the HP Way

Agilent E5500 Theory of Operation

The “phase detector with reference source” technique is the most general-purpose and cost-effective measurement approach to measure the single sideband (SSB) phase noise characteristic of oscillators. This technique demodulates the noise sidebands of the device-under-test (DUT) oscillator to a baseband signal for a fast, easy measurement using off-the-shelf baseband analyzers.

With the reference source and the DUT in steady state quadrature, the phase detector generates a baseband signal proportional to the phase difference of the two sources. When the noise characteristics of the reference source signal are less than the DUT

signal noise characteristics, the resulting baseband noise signal is effectively that of the DUT.

A narrow-band phase-lock-loop forces the two phase detector input signals into quadrature and allows the reference source to track DUT frequency drift for drift rates within the loop bandwidth.

Noise fluctuations within the loop bandwidth are suppressed by the operation of the phase-lock-loop. This suppression effect can be independently measured and the noise data corrected automatically by the measurement software. Noise fluctuations outside of the phase-lock-loop bandwidth are unaffected.

When the oscillator-under-test has a frequency output in the microwave frequency range, it is difficult to find suitable, low noise, microwave frequency sources to use as the necessary reference signal. In this case, the solution is to use a low-noise downconverter to translate the DUT microwave output frequency to a lower RF/IF frequency, allowing the use of the same low-noise RF reference sources described previously.

The phase noise of the RF reference or the microwave downconverter usually dominates effective noise floor of this phase noise measurement. The noise contribution of the baseband test set is much lower than either and typically does not factor into the overall measurement noise floor.

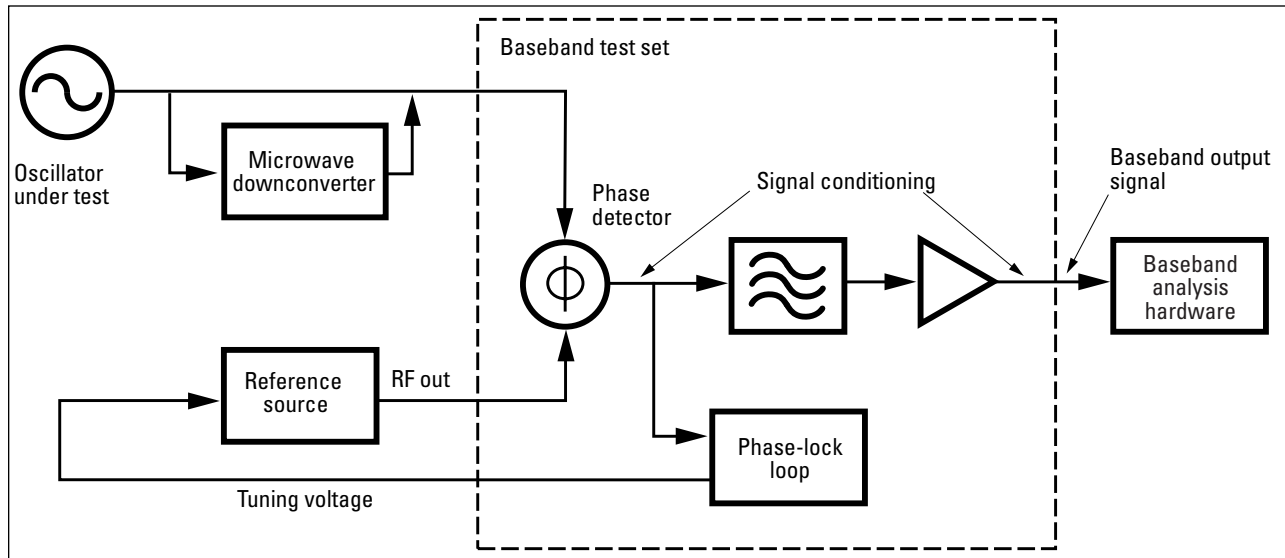

Simplified phase noise measurement diagram

Solutions for the Production ATE Environment

The Agilent E5500 A-series of phase noise measurement solutions are tailored to meet the demanding needs of production ATE. This series provides key features allowing:

- Quick and easy integration into existing ATE systems
- “Just-enough” configuration flexibility
- The lowest overall cost of measurement

This series consists of a low noise MMS baseband test set, a VXI digitizer with a high speed VXI-to-PC data interface for baseband signal measurement, and measurement software.

The MMS baseband test set provides all of the phase detectors, amplifiers, filters, switches, and attenuators necessary to measure phase noise over the IF, RF, and microwave frequency ranges directly.

The VXI digitizer samples the baseband noise signal and sends the digitized data to the measurement software for fast digital signal processing.

The measurement software provides all of the operator interaction, measurement coordination, calibration, data signal processing, and data results. The remote (SCPI) Standard Commands Programmable Instruments programming interface client provides quick and easy integration into new and existing production test environments.

Selecting the Right Amount of Test Capability

The Agilent E5500 A-series come standard with the capability to measure from 0.01 Hz to 4 MHz of offset range directly. They can optionally measure 0.01 Hz to 8 MHz or 0.01 Hz to 10 MHz directly and expanded to include the capability to measure offset ranges to 100 MHz and beyond.

The Agilent E5502/03/04A solutions include a low noise, MMS down-converter optimized for their respective frequency ranges. For example, the 6-GHz and 18-GHz down-converters have a minimum input frequency of 1 GHz allowing you to select an RF reference source with a maximum output frequency of 1 GHz. This optimization helps reduce the total, overall solution costs for phase noise measurements.

The addition of low-noise RF reference sources and microwave down-converters provide a complete phase-noise measurement solution for a wide range of IF, RF, microwave, and millimeter frequency oscillators.

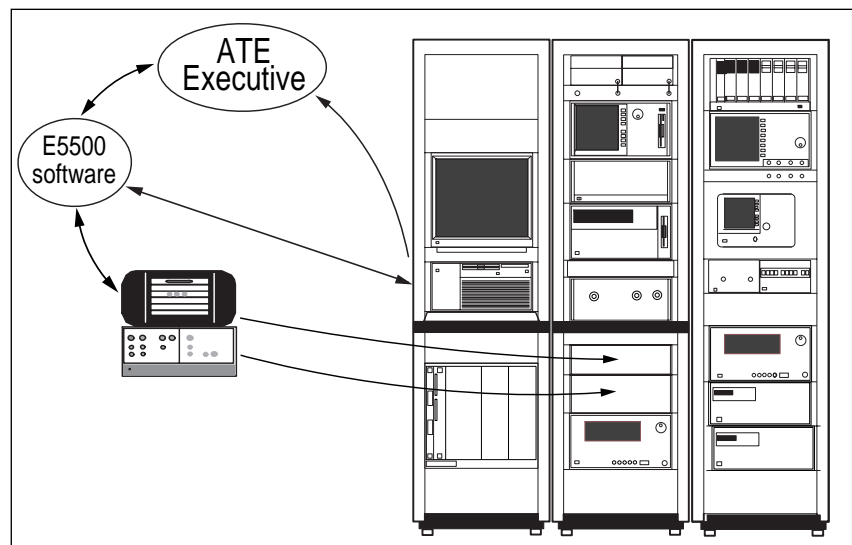

Integrating an Agilent E5503A solution into a production test environment

Expand Carrier Frequencies to 110 GHz

For absolute measurement of phase noise in the millimeter frequency bands, add the appropriate Agilent 11970 series millimeter harmonic mixers to E5504A solutions.

The 26.5-GHz microwave downconverter provides the high power, direct LO drive necessary to downconvert millimeter signals. The 45-dB variable gain IF amplifier is available to amplify the IF output of the harmonic mixer. The downconverter can also supply the DC bias to the harmonic mixer if appropriate.

Quick and Easy Integration Into Your ATE System

With a completely defined, industry standard SCPI programming interface client, the E5500 A-series can be quickly and easily integrated into your specific ATE computing environment.

If you choose to configure an E5500 series solution to run on a separate computer, initiate a measurement over LAN or GPIB using the standard, remote, phase noise SCPI command language.

Full measurement system control, including capturing measurement data, is included. If your production ATE computing environment runs under Windows NT® 4.0, a separate computer is not necessary. Simply initiate a measurement using the multitasking capability and the remote SCPI interface to communicate with the E5500 series measurement software running concurrently on your ATE computer.

Data is available in two ASCII formats: a spread sheet format and an XY graph format. Other data translators can be specified and provided.

Software summary:

- Modular, object oriented, client/server architecture
- Windows 95®-compliant graphical user interface
- Industry standard SCPI programming language
- Windows NT® 4.0 operating system
- Standard ASCII data formats

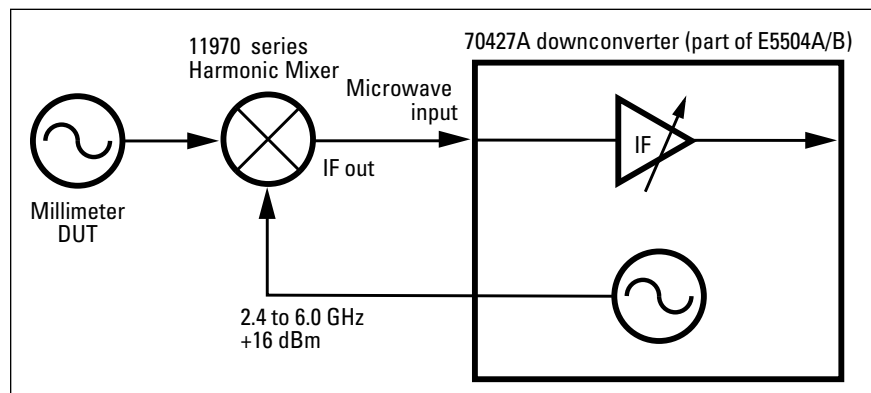

Block diagram for coverage up to 110 GHz

```

SENSe:NOISe:MEAStype ABSolute
CARRier:FREQuency:FIXed 10 MHz
REFerence:FREQuency:FIXed 10 MHz
SENSe:DETector:FREQuency 10 MHz
SENSe:DETector LFRequenc
SENSe:RANGe:OFFSet 10 Hz, 10 MHz
SENSe:RANGe:SEGTable:MEASurement:QUALity FAST
DISPlay GRAPh:TRANsform SSBNoise
INITiate:CALibrate
TTOTal?
*WAI
*STB?
CALCulate:VIEW:XYDATA
CALCulate:DATA:HEADer: POINts?
CALCulate:DATA?
    
```

A simple SCPI programming example

Ability to Test a Wide Range of Devices

The E5500 series measures the absolute, single sideband phase noise, the absolute AM noise, and the low level spurious signals of a wide range of one-port production devices with either CW or pulsed carrier signals:

- VCOs, DROs, and fixed oscillators
- Crystal oscillators and clocks
- High frequency synthesizers
- Low noise DC supplies

Measure AM Noise Directly

The E5500 series can automatically measure the AM noise of RF and microwave devices. The internal AM detector and DC blocking filter provided within Option 001 measures AM noise on carriers up to 26.5 GHz.

AM noise of millimeter frequency devices can be measured at the IF frequency automatically with the internal IF AM detector provided within the Agilent 70427A downconverter which is part of the E5504A/B solutions.

Additive Noise Measurements to Two-port Devices

The E5500 series also measures the residual (additive) phase noise, AM noise, and low level spurious signals of two-port production devices with either CW or pulsed carrier signals:

- High power amplifiers
- Frequency dividers
- Frequency multipliers
- Mixers

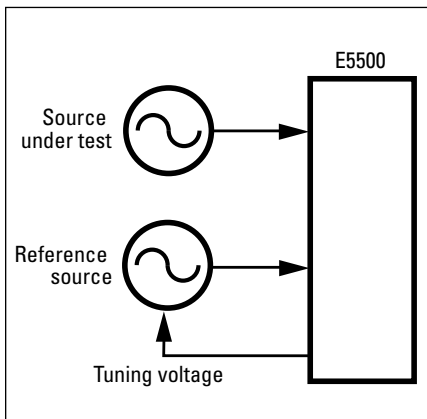

Use off-the-shelf RF signal generators or your own low-noise source as the reference source.

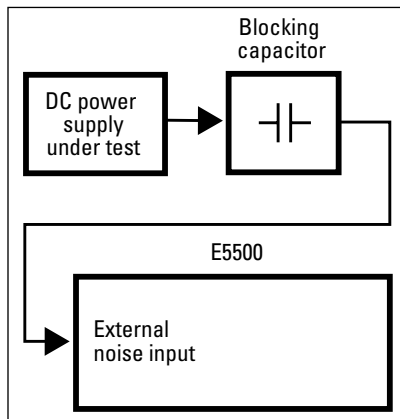

Measuring noise using the external noise input port

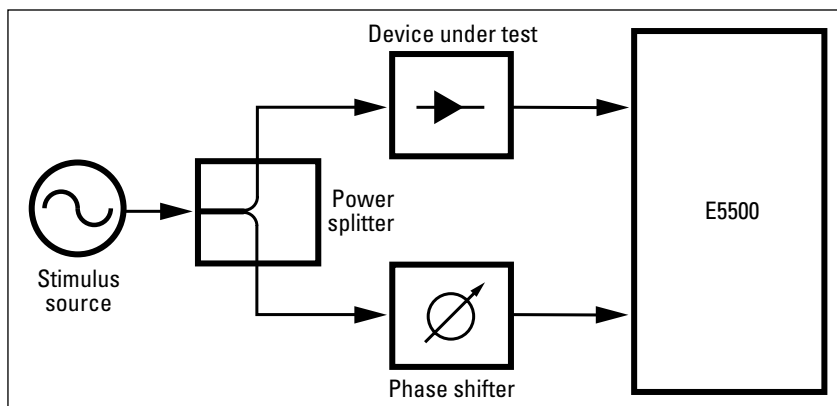

Residual noise measurement of a two-port device

Agilent E5500 Series Solutions for the R&D Benchtop Environment

The E5500 B-series have been tailored to meet the extensive development needs of the R&D engineer, providing the highest possible capability at the lowest possible cost. This series provides superior frequency offset range, capability, sensitivity, and overall value for phase noise measurements.

Superior Frequency Offset Range

The E5500 B-series provide complete 0.01 Hz to 100 MHz offset range measurement capability without the need for additional baseband analysis hardware. A PC digitizer, along with a broadband RF spectrum analyzer, provides not only a complete phase noise measurement solution, but the swept RF spectrum analyzer can also be used for many other independent R&D measurement functions. All of this for a price you might expect to pay for other, more limited, measurement solutions.

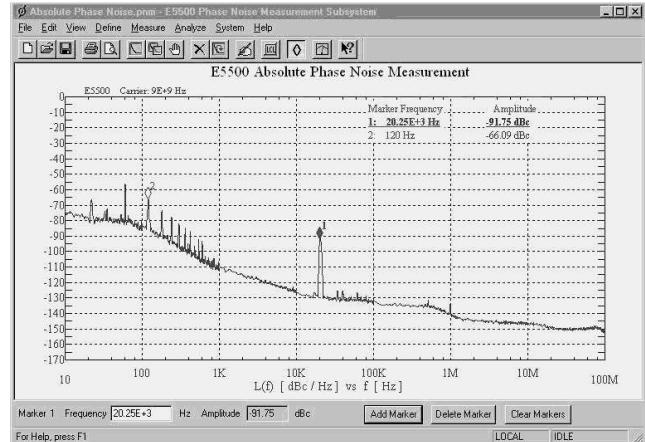

The Agilent E5500 series provides a low internal noise floor.

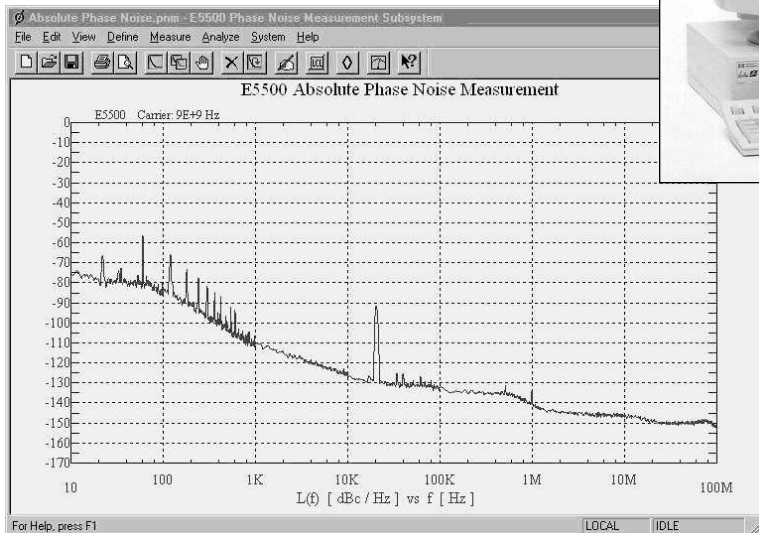
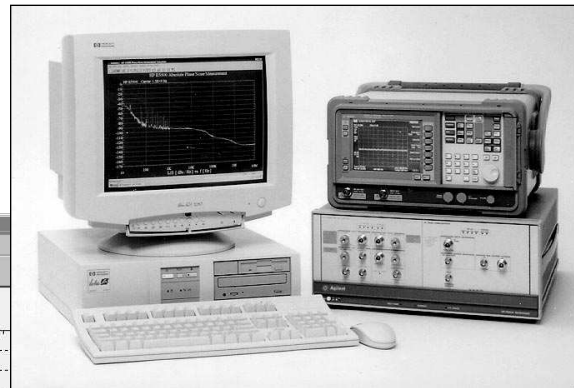

The Agilent E5500 B-series of benchtop solutions

Capability and Flexibility

The E5500 series have an internal noise floor well below the noise of most reference sources and do not require special phase detectors to lower the noise floor further.

For situations where standard RF signal generators may not offer sufficient measurement sensitivity, the E5500 series can use any voltage-tuneable source as a reference source.

Easy-to-Use GUI

The Windows 95®-compliant graphical-user-interface provides instant access to all measurement functions making it easy to configure a system, define or initiate measurements, and analyze data. The main icons are always displayed, allowing you simple and quick access to measurement information.

The forms-based graphical interaction helps you define your measurement quickly and easily. Each form tab is labeled with its content, preventing you from getting lost in the define and configure process.

To obtain a quick look at the measurement data, select the “fast” quality level. If more frequency resolution to separate spurious signals is important, select the “high resolution” quality level. And if you need to customize the offset range beyond the defaults provided, tailor the measurement segment tables to meet your needs and save them as a “custom” selection.

You can also place markers on the data trace. Select the marker icon and add up to nine data markers that can be placed and plotted with the measured data.

Other features include:

- Plotting data without spurs
- Tabular listing of spurs
- Plotting in alternate bandwidths
- Parameter summary
- Plotting several different measurements on the same displayed graph
- Color printouts to any supported color printer

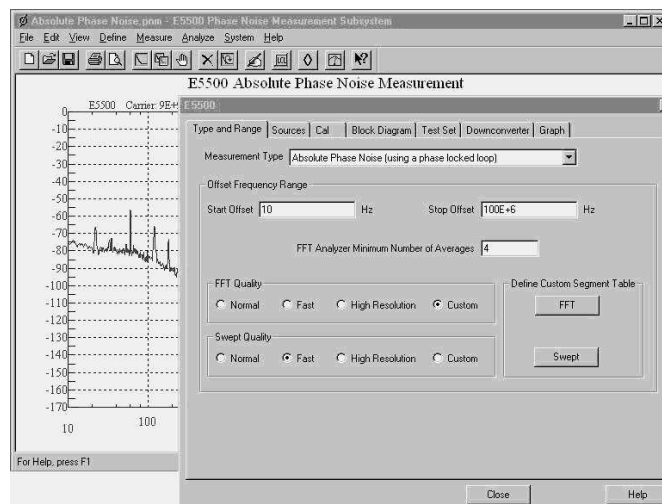

Easy-to-use forms allow fast and easy measurement configuring.

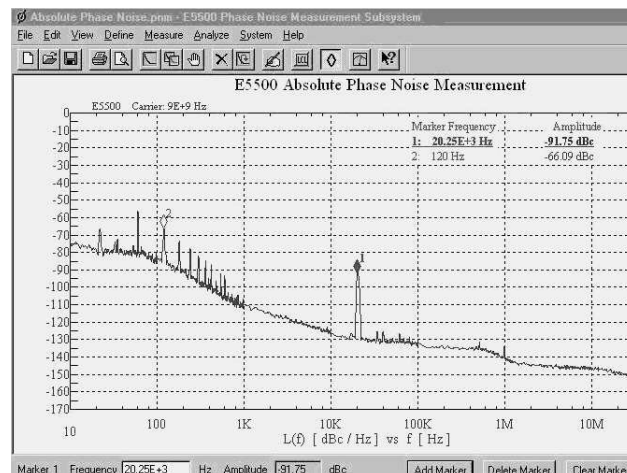

Place markers directly on the measured data.

Real-Time Monitoring of Time and Frequency Noise Data

Real-time monitoring of the noise signal is fast and easy. Choose the real-time monitor measurement mode, define the offset range you wish to view, and select the appropriate baseband analyzer role control panel.

These role control panels can also be used for measurement troubleshooting when measuring complex devices, direct manual control of reference sources, test set, or down-converters, and test development.

Share Real-Time data and Results with Other Users

Users operating other computers can view your measurements directly through the use of the E5500 series software client-server structure. The software allows multiple GUI client connections even when those GUI clients are located on other computers.

Being connected remotely allows users the opportunity to evaluate measurement results and configurations in real time.

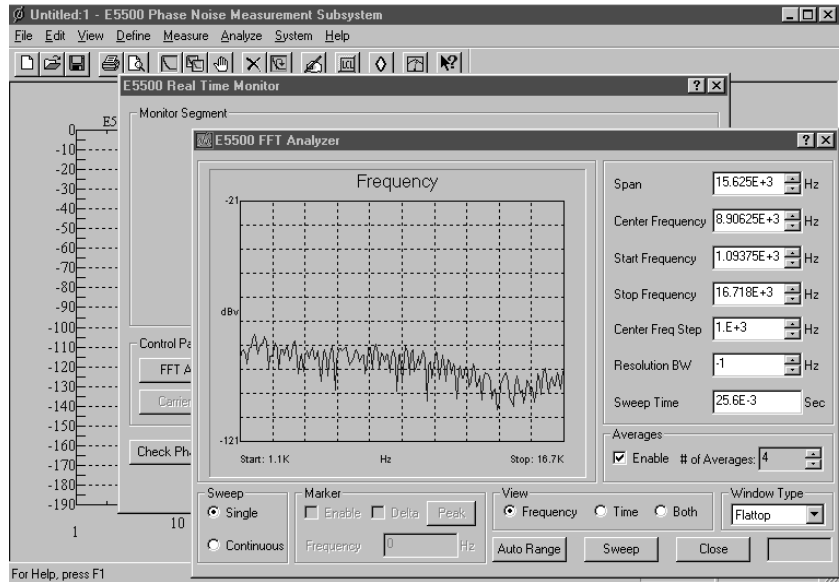

Real-time view of baseband FFT analysis showing both time domain and frequency domain data

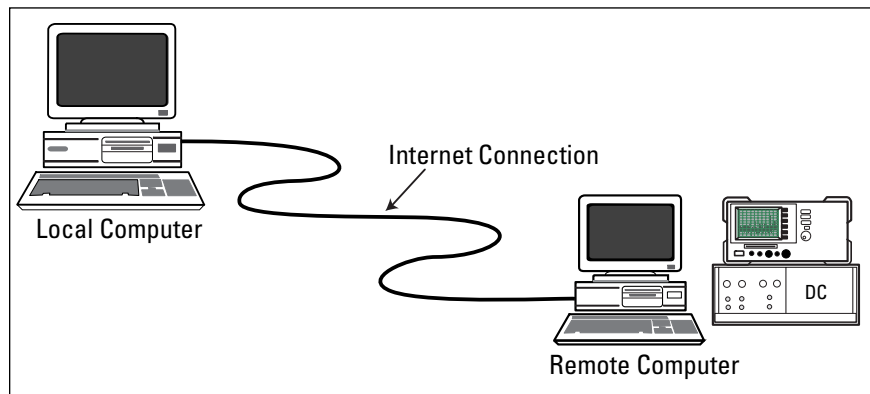

Sharing of real-time data over remote connections

Measurement Expertise and Leadership

The E5500 series provides the kind of measurement integrity and leadership that you have come to expect from Agilent Technologies. The new software design provides exceptional flexibility, measurement integrity, and low overall cost-of-measurement. The new dedicated hardware modules provide improved measurement range, proven reliability, and excellent repeatability.

A History of Leadership

In 1993 and early 1994, the National Institute of Standards Technology (NIST) in Boulder, Colorado, developed two calibration standards for use within a new on-site phase noise (PM) and amplitude (AM) noise calibration program (NIST 813003). To demonstrate how these standards can maximize confidence in evaluating the accuracy and noise floor of phase noise measurement equipment, the standards were measured at six international standards laboratories. Of the six systems actually used, three were Agilent 3048A phase noise systems.

With the help of a renowned Hewlett-Packard phase noise design engineer, they determined that the measurement error of the calibration standard's 100 MHz signal was 0.2 dB once they had eliminated the effects of harmonic distortion.

The Agilent E5500 series continues in this leadership tradition by participating in the NIST 813003 on-site noise calibration of PM and AM for phase noise measuring systems.

Worldwide Application Services and Hardware Support

Agilent has a complete, worldwide support services structure in place, providing local hardware calibration and repair and local application expertise.

On-site training for up to six operators is provided by trained phase noise application engineers. The training explains all operating modes of the E5500 series, when each measurement technique is appropriate, and how to analyze the measured data.

Additional application assistance focused on measuring your specific devices is also available.

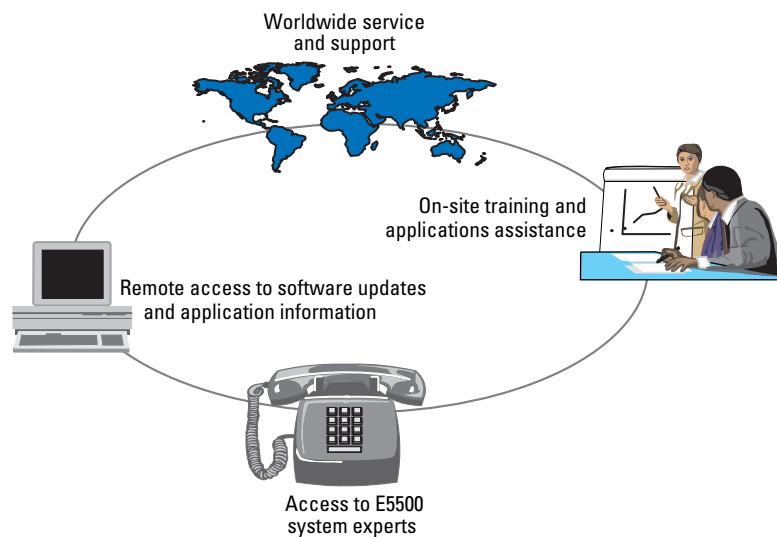

Agilent's commitment to worldwide support can provide high system uptimes in critical test environments' measuring systems.

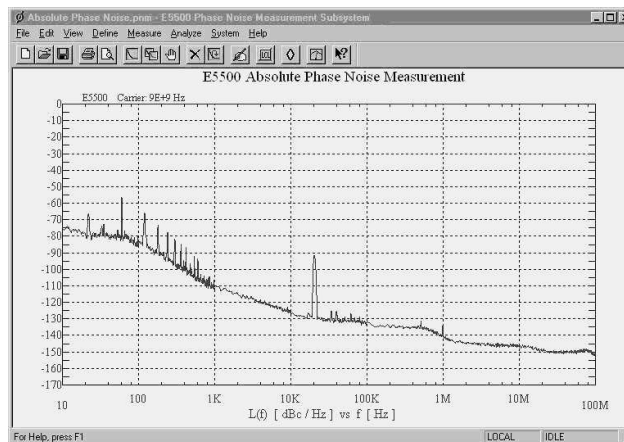

Typical Agilent E5503A/B noise floor at X-band carrier frequencies

Agilent E5500 A-Series Preconfigured Solutions

The E5500 A-series solutions have been configured to meet the needs of production test. They include industry standard VXI and MMS modular hardware to provide maximum test throughput, current and future measurement flexibility, and asset reuse. These solutions can easily include specific RF reference sources, additional baseband analysis hardware, and computers for complete production phase noise measurement solutions.

E5501A 50 kHz to 1.6 GHz
E5502A 50 kHz to 6 GHz
E5503A 50 kHz to 18 GHz
E5504A 50 kHz to 26.5 GHz

The Agilent E5500 A-series solution hardware includes:

- 0.01 Hz to 4 MHz VXI digitizer
- VXI to PC high speed interface
- 6-slot, high power VXI mainframe
- MMS baseband test set and frame

E5502/03/04A solutions add an MMS low noise downconverter.

Optional Capabilities

- Extend offset range to 8, 10, and 100 MHz
- Add RF reference source
- Add high power input capability (includes μ W phase and AM detectors)
- Add specific ATE computer
- Extend carrier frequency to 110 GHz

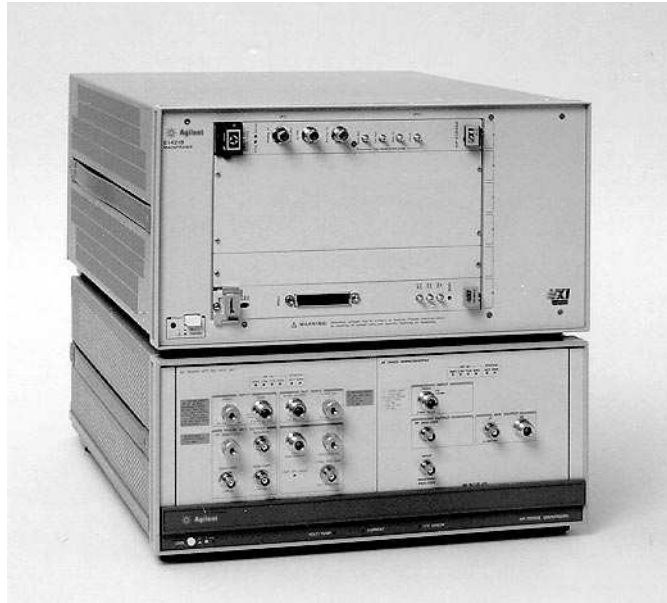

The Agilent E5503A configuration

Operating Characteristics

Offset frequency range:

0.01 Hz to 4 MHz

System noise response:¹

-180 dBc/Hz typically
(>10 kHz offsets)

System spurious response:¹

<-120 dBc typically

Phase detector input power:

(<1.6 GHz carrier frequency)

R input = 0 to +23 dBm

L input = +15 to +23 dBm

Downconverter input range:

1 GHz to 6 GHz

1 GHz to 18 GHz

1.5 GHz to 26.5 GHz

External noise input port:

0.01 Hz to 100 MHz

Measurement accuracy:

± 2 dB (<1.0 MHz offsets)

± 4 dB (<100 MHz offsets)

1. Without reference sources or downconverters.

Agilent E5500 B-Series Preconfigured Solutions

The E5500 B-series have been configured to meet the needs of R&D benchtop applications. The configurations include complete base-band analysis and MMS modular hardware to provide maximum offset range and capability. These solutions can easily include specific RF reference sources.

E5501B 50 kHz to 1.6 GHz
E5502B 50 kHz to 6 GHz
E5503B 50 kHz to 18 GHz
E5504B 50 kHz to 26.5 GHz

The Agilent E5500 B-series solution hardware includes:

- 1.5 GHz swept RFSA
- MMS baseband test set and frame
- Pentium® PC with Windows NT® 4.0 and digitizer

E5502/03/04B solutions add a low noise MMS downconverter.

Optional Capabilities

- Add RF reference source
- Add high power input capability (includes mW phase and AM detectors)
- Delete PC
- Add remote SCPI programming client
- Extend carrier frequency to 110 GHz

Operating Characteristics

Offset frequency range:
0.01 Hz to 100 MHz

System noise floor (<1.6 GHz):¹
–180 dBc/Hz typically
(>10 kHz offsets)

System spurious response:¹
–120 dBc typically

Phase detector input power:
R input = 0 to +23 dBm
L input = +15 to +23 dBm

Downconverter input range:
1 GHz to 6 GHz
1 GHz to 18 GHz
1.5 GHz to 26.5 GHz

External noise input port:
0.01 Hz to 1.0 MHz

Measurement accuracy:
±2 dB (<1.0 MHz offsets)
±4 dB (<100 MHz offsets)

Related Literature

Configuration Guide 5965-7589E

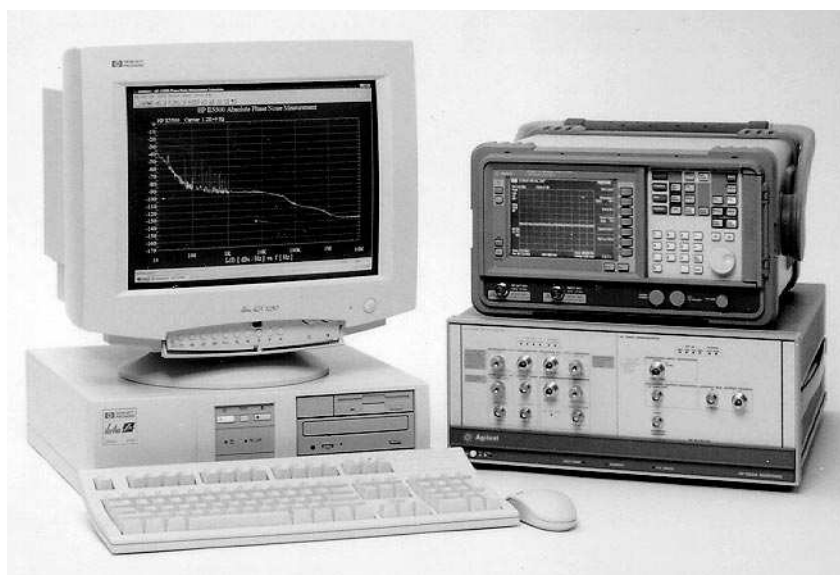

The Agilent E5503B configuration

1. Without reference sources or downconverters.

Agilent Technologies' Test and Measurement Support, Services, and Assistance

Agilent Technologies aims to maximize the value you receive, while minimizing your risk and problems. We strive to ensure that you get the test and measurement capabilities you paid for and obtain the support you need. Our extensive support resources and services can help you choose the right Agilent products for your applications and apply them successfully. Every instrument and system we sell has a global warranty. Support is available for at least five years beyond the production life of the product. Two concepts underlie Agilent's overall support policy: "Our Promise" and "Your Advantage."

Our Promise

"Our Promise" means your Agilent test and measurement equipment will meet its advertised performance and functionality. When you are choosing new equipment, we will help you with product information, including realistic performance specifications and practical recommendations from experienced test engineers. When

you use Agilent equipment, we can verify that it works properly, help with product operation, and provide basic measurement assistance for the use of specified capabilities, at no extra cost upon request. Many self-help tools are available.

Your Advantage

"Your Advantage" means that Agilent offers a wide range of additional expert test and measurement services, which you can purchase according to your unique technical and business needs. Solve problems efficiently and gain a competitive edge by contracting with us for calibration, extra-cost upgrades, out-of-warranty repairs, and on-site education and training, as well as design, system integration, project management, and other professional services. Experienced Agilent engineers and technicians worldwide can help you maximize your productivity, optimize the return on investment of your Agilent instruments and systems, and obtain dependable measurement accuracy for the life of those products.

By internet, phone, or fax, get assistance with all your test and measurement needs.

Online Assistance

www.agilent.com/find/assist

Phone or Fax

United States:

(tel) 1 800 452 4844

Canada:

(tel) 1 877 894 4414

(fax) (905) 206 4120

Europe:

(tel) (31 20) 547 2323

(fax) (31 20) 547 2390

Japan:

(tel) (81) 426 56 7832

(fax) (81) 426 56 7840

Latin America:

(tel) (305) 269 7500

(fax) (305) 269 7599

Australia:

(tel) 1 800 629 485

(fax) (61 3) 9272 0749

New Zealand:

(tel) 0 800 738 378

(fax) (64 4) 495 8950

Asia Pacific:

(tel) (852) 3197 7777

(fax) (852) 2506 9284

Product specifications and descriptions in this document subject to change without notice.

Copyright © 1997, 2000 Agilent Technologies

Printed in U.S.A. 7/00

5965-7590E

**Agilent Technologies**

Innovating the HP Way