



Agilent 84125 Series

Microwave EMI Measurement Systems

Product Overview

84125A 1 to 18 GHz
84125B 1 to 26.5 GHz
84125C 1 to 40 GHz

Test Electromagnetic Emissions from 1 to 40 GHz

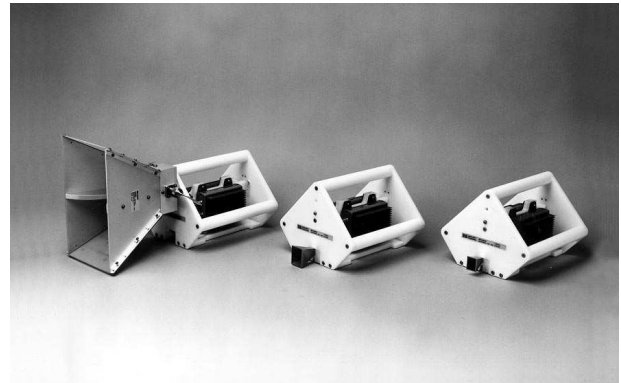

Agilent 84125 Series Test Systems

Three system configurations allow you to perform electromagnetic interference (EMI) compliance tests on product emissions above 1 GHz. The Agilent Technologies 84125A, B, and C microwave EMI test systems cover the 1 to 18 GHz, 1 to 26.5 GHz, and 1 to 40 GHz frequency ranges, respectively.

System features include:

- **Field-strength measurement calibration**
- **High measurement sensitivity**
- **Mobile configuration**
- **Easy-to-use test interface**
- **General purpose signal analysis capability from 9 kHz**



Agilent Technologies

Innovating the HP Way

Test Products to U.S. and European EMI Standards from 1 to 40 GHz

The Agilent 84125A, B, and C microwave EMI measurement systems are designed to test electromagnetic emissions from intentional and unintentional radiators over frequencies from 1 to 40 GHz. Each system is fully integrated and calibrated for testing products to rigorous FCC regulations. Microwave EMI regulations cover a wide range of wireless network products including cordless telephones, pagers, security monitors, and spread spectrum transceivers. Equipment manufacturers, EMC test laboratories, and regulatory authorities will find the 84125 series microwave test systems a valuable addition to their existing EMI test capability. Agilent 84125 series systems include a microwave EMC analyzer or spectrum analyzer and accessories mounted on an instrument cart.

The cart-mounted equipment is connected to a microwave test set with a 3 meter low-loss RF cable assembly maximizing system sensitivity. The functionality of the Agilent 8593EM or 8564E analyzers and the microwave test set is combined using a system downloadable program (DLP). The system DLP provides softkeys on the analyzer display allowing easy setup of measurement parameters. The displayed data is corrected for antenna, cable and filter losses, and amplifier gains allowing direct viewing of emission field strengths in dBuV/m. In addition, the 8593EM EMC analyzer supplied with 84125A and B systems can perform general purpose signal analysis and EMI precompliance tests starting from 9 kHz. The 8564E microwave spectrum analyzer supplied with the 84125C can perform general purpose signal analysis starting from 100 Hz.

The system test set is designed for tripod or antenna mast mounting or for handheld use for locating worst-case product emissions. A separate, non-metallic tripod accessory is available (Agilent 11968C). Horn antennas can be interchanged in the 84125B and C systems for full frequency coverage from 18 to 26.5 GHz and 26.5 to 40 GHz. In addition, each system includes three high-pass filters that can be used to block fundamental frequencies when testing intentional radiators. The interchangeable high-pass filters block signals below their respective 1.5 GHz, 3.5 GHz, and 8.25 GHz cut-off frequencies.

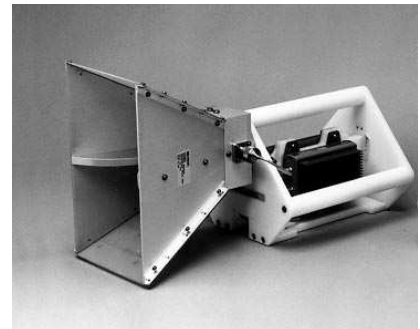

1 to 18 GHz antenna mounted to microwave test set

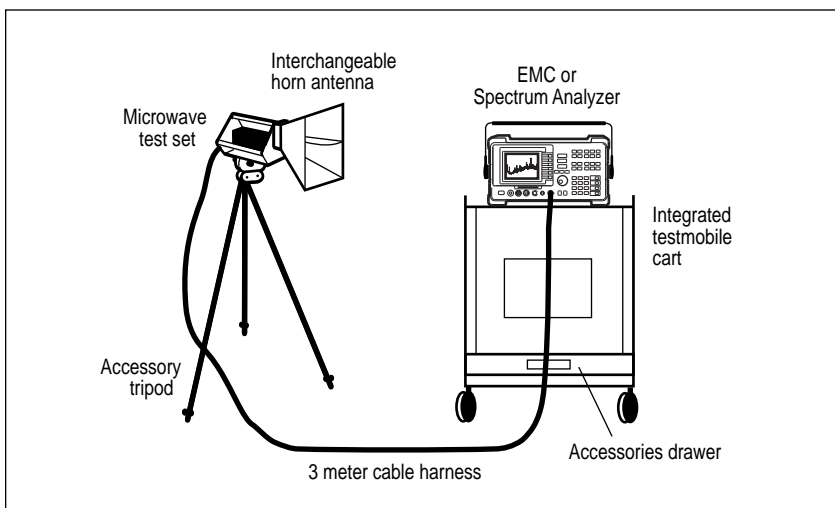

Agilent 84125 Series Test System

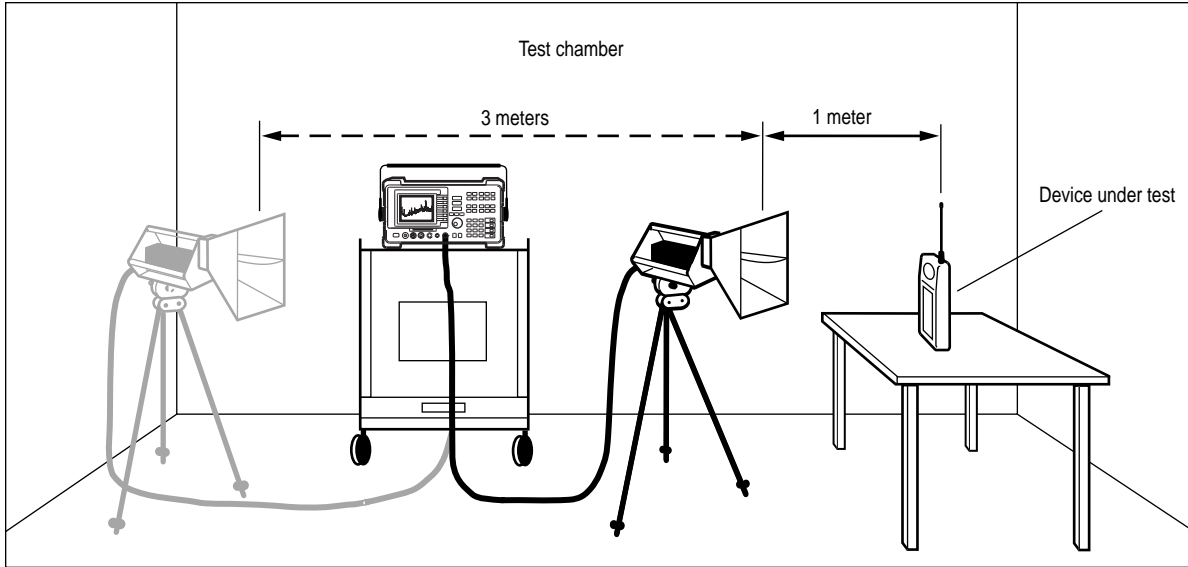

Agilent 84125 Series Test System

Test Chamber Microwave EMI Measurements

Positioning the mobile test cart and microwave test set inside the test chamber minimizes cable length and increases measurement sensitivity. Two high-gain microwave amplifiers provide additional sensitivity, which results in a low inherent system noise level. The microwave test set and horn antenna can be positioned for maximum emission levels and rotated 90 degrees to test for both horizontal or vertical signal polarizations.

The worst-case device emissions can be located by positioning the test set and antenna one meter from the test device and rotating the device on a turntable while observing signals on the EMC analyzer's display. The close-up measurement gives added sensitivity for finding emissions. When worst-case emissions are determined, the antenna can be repositioned to the test distance specified in EMI regulations, typically three meters. The device worst-case emission levels can then be compared to

the regulatory emission limits. For example, in the U.S., FCC Part 15 regulations set maximum emission limits for signals up to the tenth harmonic of the fundamental frequencies of intentional radiators. The maximum emission levels of the harmonics must be below a field strength of 54 dBuV/m at a test distance of three meters (or 63.5 dBuV/m at a test distance of one meter).

The 84125A microwave EMI test system display shows harmonic emission levels of an intentional radiator compared to a 64 dBuV/m field strength level at one meter.

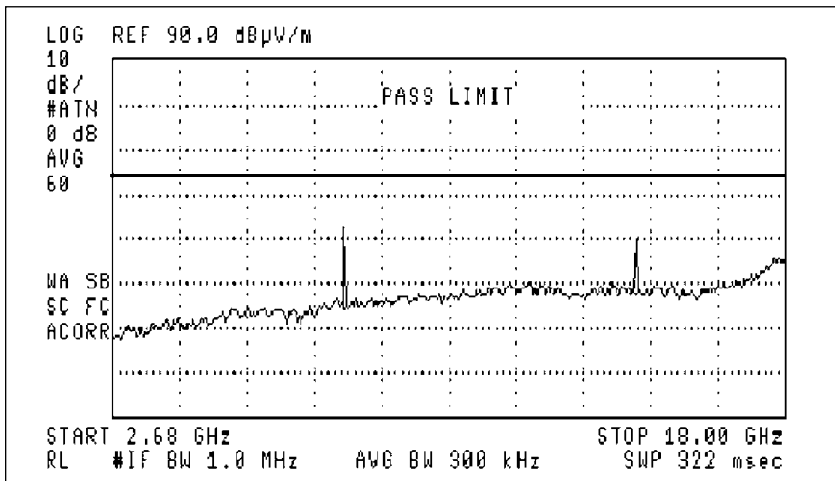

Agilent 84125 Series Test System

Typical System Measurement Performance

Typical 84125 series system measurement sensitivities are shown graphically for three bands, 1 to 18 GHz, 18 to 26.5 GHz, and 26.5 to 40 GHz. The average measurement sensitivities are measured in a 1 MHz bandwidth using typical transducer factors for each of the 84125 series system antennas. For reference, the FCC Part 15 three-meter limit of 54 dBuV/m is shown on each graph.

Agilent 84125A, B, C

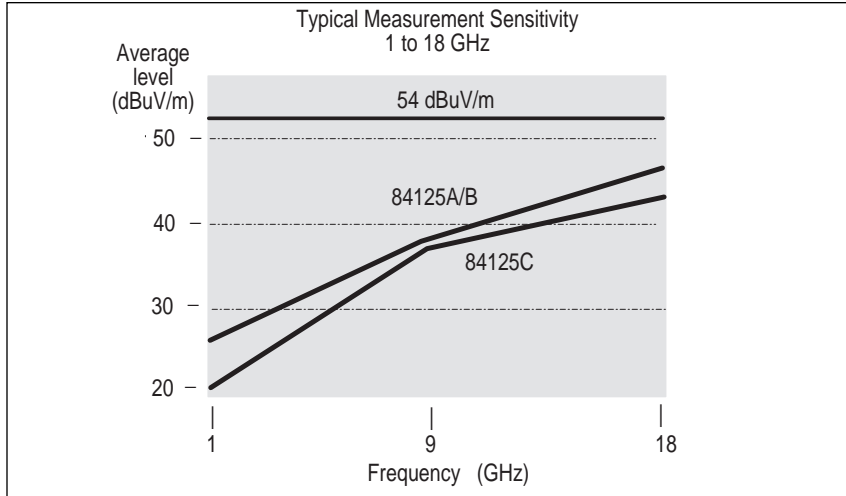

Agilent 84125B, C

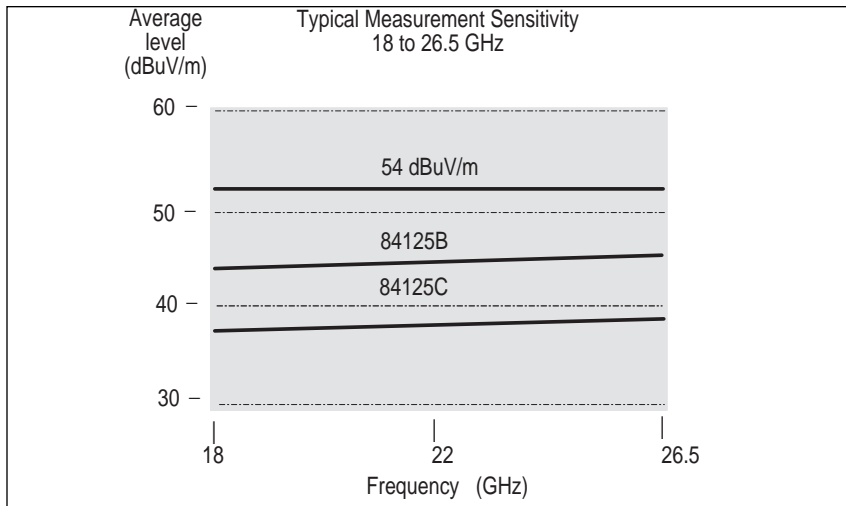

Agilent 84125C

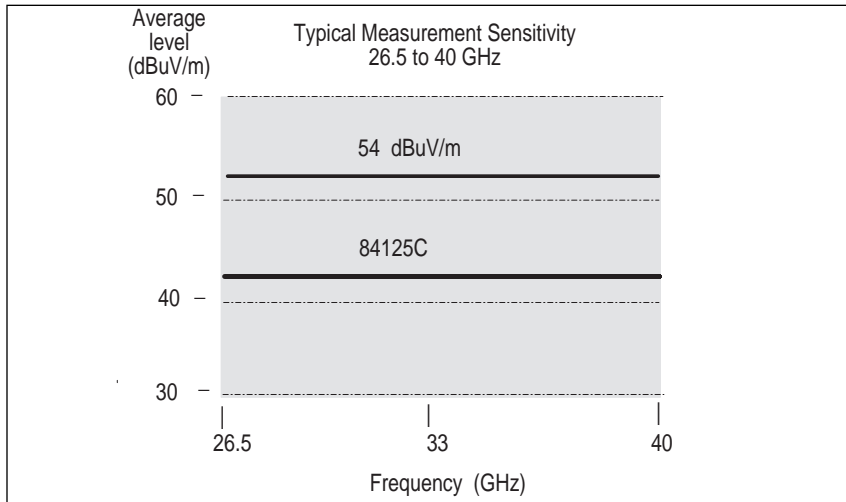

Agilent 84125A, B, C Systems Integration and Calibration

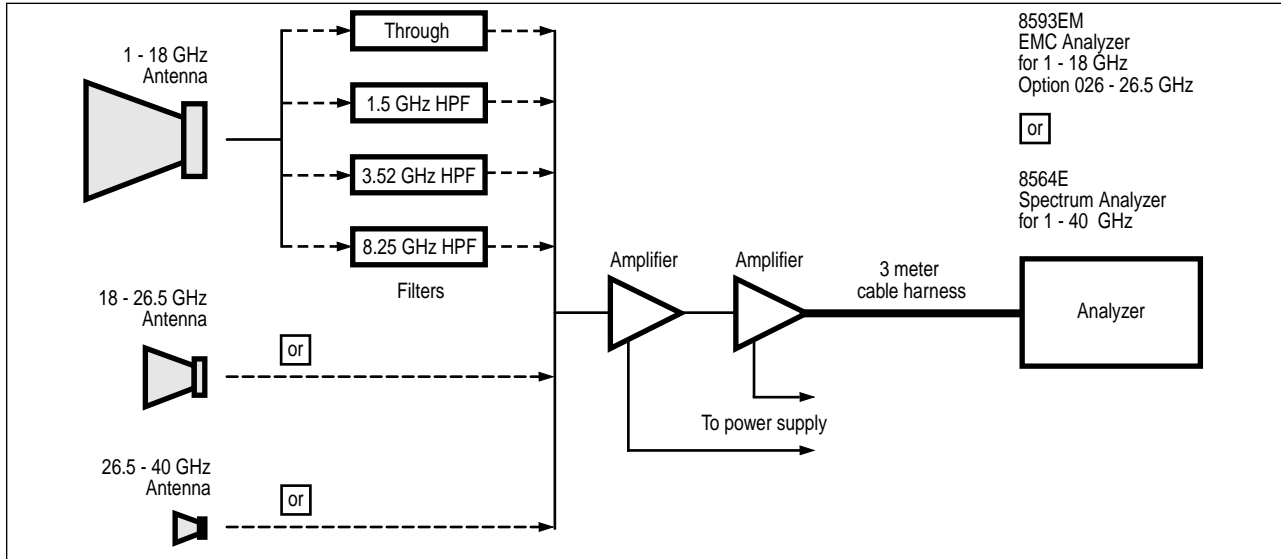

Agilent 84125 Series System Configuration

The measurement sensitivity of 84125 series systems is determined by the system noise level and the conversion

factors for each horn antenna. Calibration data for system amplifiers, cables, filters, and antennas are stored in the analyzer's memory for automatic data correction. The EMC

and spectrum analyzers provide an easy-to-use measurement interface allowing quick recall of measurement settings and the display of corrected measurement results.

Test System Specifications

Model	Frequency Range (GHz)	Displayed Average Noise Level (dBuV) ¹		Third Order Intercept (dBuV) Characteristic
		Specified	Typical	
84125A	1 to 18	8	-1	>45
84125B	1 to 18	8	-1	>45
	18 to 26.5	15	5	
84125C	1 to 18	6	-3	>50
	18 to 26.5	6	-1	
	26.5 to 40	9	0	

Test Set Specifications (Amplifier, filter, and cable assembly)

Calibration data uncertainty	± 0.9 dB
Flatness uncertainty	± 1.7 dB Typical
Test set repeatability	± 0.7 dB ² Typical
Maximum temperature drift	± 1.5 dB ³ Typical
Input VSWR	
1 to 18 GHz	3.2:1 Typical
18 to 40 GHz	2.3:1 Typical

1. Specified noise levels are worst-case over respective frequency ranges and are measured in a 1 MHz bandwidth.
2. Test set repeatability includes cable flexure, amplifier aging, and connection repeatability.
3. System specifications apply between the ambient temperatures of 20 °C to 30 °C.

Agilent 84125 Series System Antenna and Filter Specifications

Horn Antenna Specifications

Frequency Range (GHz)	Antenna Factor (Typical) ¹		VSWR (Typical)
	Range (dB/m)	Uncertainty (±dB)	
1 to 18	24 to 47	2	2.8:1
18 to 26.5	40 to 41	0.5	1.4:1
26.5 to 40	43 to 44	0.5	1.4:1

Test Set Filter Specifications

Frequency Range (GHz)	Passband (GHz)	60 dB Rejection (GHz)	Passband VSWR (Typical)
1 to 18	1.5 to 18	≤ 0.95	2.1:1
1 to 18	3.52 to 18	≤ 2.5	2.1:1
1 to 18	8.25 to 18	≤ 5.9	2.3:1

EMI Accessories

Nonmetallic tripod		11968C
Biconical antenna	30 to 300 MHz	11966C
Log periodic antenna	300 to 1000 MHz	11966D
Broadband antenna	30 to 1000 MHz	11966P

1. Antenna factors are specified at a 1 meter calibration distance.

Agilent Technologies' Test and Measurement Support, Services, and Assistance

Agilent Technologies aims to maximize the value you receive, while minimizing your risk and problems. We strive to ensure that you get the test and measurement capabilities you paid for and obtain the support you need. Our extensive support resources and services can help you choose the right Agilent products for your applications and apply them successfully. Every instrument and system we sell has a global warranty. Support is available for at least five years beyond the production life of the product. Two concepts underlie Agilent's overall support policy: "Our Promise" and "Your Advantage."

Our Promise

"Our Promise" means your Agilent test and measurement equipment will meet its advertised performance and functionality. When you are choosing new equipment, we will help you with product information, including realistic performance specifications and practical recommendations from experienced test engineers. When

you use Agilent equipment, we can verify that it works properly, help with product operation, and provide basic measurement assistance for the use of specified capabilities, at no extra cost upon request. Many self-help tools are available.

Your Advantage

"Your Advantage" means that Agilent offers a wide range of additional expert test and measurement services, which you can purchase according to your unique technical and business needs. Solve problems efficiently and gain a competitive edge by contracting with us for calibration, extra-cost upgrades, out-of-warranty repairs, and on-site education and training, as well as design, system integration, project management, and other professional services. Experienced Agilent engineers and technicians worldwide can help you maximize your productivity, optimize the return on investment of your Agilent instruments and systems, and obtain dependable measurement accuracy for the life of those products.

By internet, phone, or fax, get assistance with all your test and measurement needs.

Online Assistance

www.agilent.com/find/assist

Phone or Fax

United States:

(tel) 1 800 452 4844

Canada:

(tel) 1 877 894 4414

(fax) (905) 206 4120

Europe:

(tel) (31 20) 547 2323

(fax) (31 20) 547 2390

Japan:

(tel) (81) 426 56 7832

(fax) (81) 426 56 7840

Latin America:

(tel) (305) 269 7500

(fax) (305) 269 7599

Australia:

(tel) 1 800 629 485

(fax) (61 3) 9272 0749

New Zealand:

(tel) 0 800 738 378

(fax) (64 4) 495 8950

Asia Pacific:

(tel) (852) 3197 7777

(fax) (852) 2506 9284

Product specifications and descriptions in this document subject to change without notice.

Copyright © 1998, 2000 Agilent Technologies
Printed in U.S.A. 7/00
5965-5477E

**Agilent Technologies**

Innovating the HP Way