

Agilent V/W281C,D

mm-Wave-to Coax Adapters

50 to 110 GHz

Product Overview

- Excellent repeatability
- Measurement versatility
- WR-15, WR-10 (V,W band waveguide)
- Precision 1-mm coax connectors

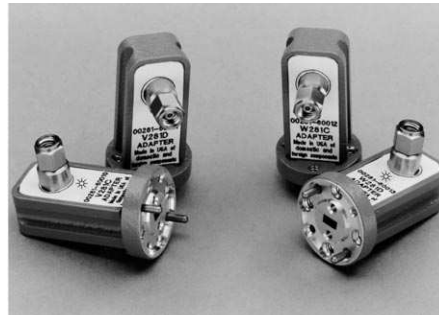

Increased measurement versatility

Coax measurements to 110 GHz. The Agilent Technologies V/W281C,D precision 1 millimeter waveguide-to-coax adapters offer a simple, low SWR transition between transmission media. Take advantage of stable, low loss, and low SWR waveguide when measuring coaxial devices at higher frequencies. Or keep the convenience of coax, even when testing waveguide components. V/W281 adapters increase the versatility of test systems, like the Agilent 8510XF, to measure both coax and waveguide components.

Excellent accuracy

Low SWR transitions reduce mismatch uncertainty and excellent repeatability ensures consistent measurements. Available with both male and female connectors, these adapters help microwave engineers combine the best test components from each transmission media. With the V/W281 adapters, engineers can balance the merits of coax and waveguide to achieve the best combination of accuracy, cost, and ease-of-use.

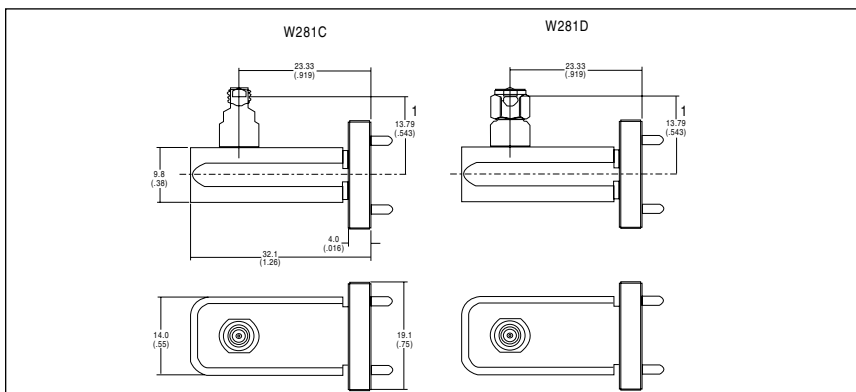
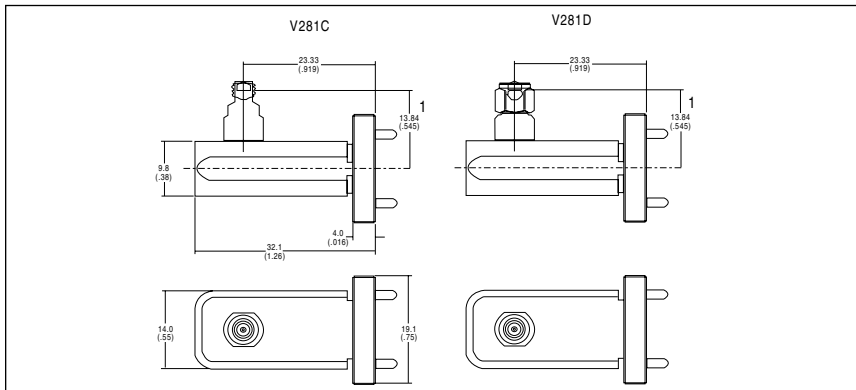

1. Length from mating surface of 1-mm connector to center line of waveguide aperture.



Agilent Technologies

Innovating the HP Way

Specifications

Specifications describe the instrument's warranted performance over the temperature range 0 to 55 °C (except where noted). **Supplemental characteristics** are intended to provide information useful in applying the instrument by giving typical but nonwarranted performance parameters. These are denoted as "typical," "nominal," or "approximate."

Coax-to-waveguide adapters

Model number	Coax connector type ¹	Waveguide number	Frequency (GHZ)	Supplemental characteristics		
				Return loss better than:	Insertion loss ²	Repeatability ^{3,4} typically better than:
V281C	1 mm (f)	WR-15	50 to 75	-16 dB	≥-0.8 dB	-45 dB
V281D	1 mm (m)	WR-15	50 to 75	-16 dB	≥-0.8 dB	-45 dB
W281C	1 mm (f)	WR-10	75 to 110	-16 dB	≥-1 dB	-40 dB
W281D	1 mm (m)	WR-10	75 to 110	-16 dB	≥-1 dB	-40 dB

1. f = jack, m = plug

2. Maximum insertion loss for a single adapter.

3. At the coaxial port only.

4. Repeatability = $20 \log |\Delta G|$ where $|\Delta G| = |G_{m_1} - G_{m_2}|$. This is the difference between two measurements G_{m_1} and G_{m_2} before and after one disconnect/connect cycle at the coax port. Repeatability depends upon proper torque and pin depth.

Environmental Specifications

	Non-operating	Operating
Temperature	-40 to +75 °C	0 to 55 °C
Altitude	<15,000 meters (50,000 ft)	<15,000 meters (50,000 ft)

Note: Storage or operation within an environment other than that specified above may cause damage to the product and may void the warranty.

Non-operating environmental specifications apply to storage and shipment. Products should be stored in a clean, dry environment. Operating environmental specifications apply when the product is in use. Products should not be operated in a condensing environment.

Care, connection, and torque

For more information, review the Operating Service Guide for the V/W281C,D adapters, 00281-90056.

Agilent Technologies' Test and Measurement Support, Services, and Assistance

Agilent Technologies aims to maximize the value you receive, while minimizing your risk and problems. We strive to ensure that you get the test and measurement capabilities you paid for and obtain the support you need. Our extensive support resources and services can help you choose the right Agilent products for your applications and apply them successfully. Every instrument and system we sell has a global warranty. Support is available for at least five years beyond the production life of the product. Two concepts underlie Agilent's overall support policy: "Our Promise" and "Your Advantage."

Our Promise

"Our Promise" means your Agilent test and measurement equipment will meet its advertised performance and functionality. When you are choosing new equipment, we will help you with product information, including realistic performance specifications and practical recommendations from experienced test engineers. When you use Agilent equipment, we can verify that it works properly, help with product operation, and provide basic measurement assistance for the use of specified capabilities, at no extra cost upon request. Many self-help tools are available.

Your Advantage

"Your Advantage" means that Agilent offers a wide range of additional expert test and measurement services, which you can purchase according to your unique technical and business needs. Solve problems efficiently and gain a competitive edge by contracting with us for calibration, extra-cost upgrades, out-of-warranty repairs, and on-site education and training, as well as design, system integration, project management, and other professional services. Experienced Agilent engineers and technicians worldwide can help you maximize your productivity, optimize the return on investment of your Agilent instruments and systems, and obtain dependable measurement accuracy for the life of those products.

Get assistance with all your test and measurement needs at:
www.agilent.com/find/assist

Product specifications and descriptions in this document subject to change without notice.

Copyright © 1998, 2000 Agilent Technologies
Printed in U.S.A. 8/00
5966-2007E



Agilent Technologies

Innovating the HP Way